



**MINMAX<sup>®</sup>**

MIHW2000 Series

Electric Characteristic Note

# MIHW2000 Series EC Note

DC-DC CONVERTER 3W, Reinforced Insulation, Medical Safety

## Features

- ▶ Industrial Standard DIP-24 Package
- ▶ Ultra-Wide 4:1 Input Voltage Range
- ▶ Fully Regulated Output Voltage
- ▶ I/O Isolation 4000VAC with Reinforced Insulation, rated for 1000Vrms Working Voltage
- ▶ Low I/O Leakage Current < 2μA
- ▶ Operating Ambient Temp. Range -40°C to +85°C
- ▶ Under-Voltage, Overload and Short Circuit Protection
- ▶ Conducted EMI EN 55011/22 Class A Approved
- ▶ Medical EMC Standard with 4<sup>th</sup> Edition of EMI EN 55011 and EMS EN 60601-1-2 Approved
- ▶ Medical Safety with 1xMOPP & 2xMOOP per 3.2 Edition of IEC/EN 60601-1 & ANSI/AAMI ES60601-1 Approved
- ▶ UL/cUL/IEC/EN 60950-1 Safety Approval & CE Marking

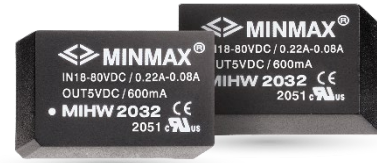

## Applications

- ▶ Distributed power architectures
- ▶ Workstations
- ▶ Computer equipment
- ▶ Communications equipment

## Product Overview

The MINMAX MIHW2000 series is a range of high performance DC-DC converter modules with a reinforced insulation system. The I/O isolation voltage is specified for 4000VAC with reinforced insulation, which rated for 1000Vrms working voltage. The product comes in a small DIP-24 package. There are 12 models available with 24V, 48V or 110VDC input and single or dual output voltages.

Full SMD design with exclusive use of ceramic capacitors guarantees a high reliability with calculated MTBF of >1 million hours. These high isolation DC-DC converters are the perfect solution for many demanding applications in industrial and railroad systems, in medical instrumentation, everywhere where a certified supplementary or reinforced insulation system is required to comply with specific industrial or medical safety standards.

## Table of contents

Model Selection Guide .....	P2	Recommended Pad Layout for Single & Dual Output Converter.....	P16
Input Specifications.....	P2	Test Setup.....	P17
Output Specifications.....	P2	Technical Notes .....	P17
Isolation, Safety Standards.....	P3	Packaging Information for Tube .....	P18
General Specifications.....	P3	Wave Soldering Considerations.....	P18
EMC Specifications.....	P3	Hand Welding Parameter .....	P18
Environmental Specifications .....	P3	Part Number Structure .....	P19
Characteristic Curves .....	P4	MTBF and Reliability .....	P19
Package Specifications .....	P16		

Model Selection Guide									
Model Number	Input Voltage (Range)	Output Voltage	Output Current		Input Current		Reflected Ripple Current	Max. capacitive Load	Efficiency (typ.)
			Max.	Min.	@Max. Load	@No Load			@Max. Load
	VDC	VDC	mA	mA	mA(typ.)	mA(typ.)	mA (typ.)	μF	%
MIHW2022	24 (9 ~ 40)	5	600	90	160	20	15	1000	78
MIHW2023		12	250	37.5	151			470	83
MIHW2026		±12	±125	±18.8	151			220#	83
MIHW2027		±15	±100	±15	151			220#	83
MIHW2032	48 (18 ~ 80)	5	600	90	80	10	8	1000	78
MIHW2033		12	250	37.5	75			470	83
MIHW2036		±12	±125	±18.8	75			220#	83
MIHW2037		±15	±100	±15	75			220#	83
MIHW2042	110 (36 ~ 160)	5	600	90	35	5	3	1000	78
MIHW2043		12	250	37.5	33			470	83
MIHW2046		±12	±125	±18.8	33			220#	83
MIHW2047		±15	±100	±15	33			220#	83

# For each output

Input Specifications					
Parameter	Model	Min.	Typ.	Max.	Unit
Input Surge Voltage (1 sec. max.)	24V Input Models	-0.7	---	50	VDC
	48V Input Models	-0.7	---	100	
	110V Input Models	-0.7	---	180	
Start-Up Threshold Voltage	24V Input Models	8	8.5	9	VDC
	48V Input Models	13	15	17	
	110V Input Models	26	30	34	
Under Voltage Shutdown	24V Input Models	---	---	8.5	VDC
	48V Input Models	---	---	16	
	110V Input Models	---	---	32	
Short Circuit Input Power	All Models	---	---	2000	mW
Input Filter		Internal Pi Type			

Output Specifications						
Parameter	Conditions / Model	Min.	Typ.	Max.	Unit	
Output Voltage Setting Accuracy		---	---	±1.0	%Vnom.	
Output Voltage Balance	Dual Output, Balanced Loads	---	±0.5	±2.0	%	
Line Regulation	Vin=Min. to Max. @Full Load	---	±0.3	±0.5	%	
Load Regulation	Io=25% to 100%	---	±0.5	±1.0	%	
Ripple & Noise	0-20 MHz Bandwidth	5V Output Models	---	75	100	mV <sub>P-P</sub>
		Other Output Models	---	100	150	mV <sub>P-P</sub>
Transient Recovery Time	25% Load Step Change	---	150	500	μs	
Transient Response Deviation		---	±3	±6	%	
Temperature Coefficient		---	±0.02	±0.05	%/°C	
Over Load Protection	Foldback	120	150	---	%	
Short Circuit Protection	Continuous, Automatic Recovery					

Isolation, Safety Standards					
Parameter	Conditions	Min.	Typ.	Max.	Unit
I/O Isolation Voltage	60 Seconds	4000	---	---	VAC
	Reinforced insulation, rated for 1000Vrms working voltage				
Leakage Current	240VAC, 60Hz	---	---	2	μA
I/O Isolation Resistance	500 VDC	10	---	---	GΩ
I/O Isolation Capacitance	100kHz, 1V	---	7	13	pF
Safety Standards	UL/cUL 60950-1, CSA C22.2 No. 60950-1				
	ANSI/AAMI ES60601-1, CAN/CSA-C22.2 No. 60601-1				
	IEC/EN 60950-1, IEC/EN 60601-1 3.2 Edition 1xMOPP & 2xMOOP				
Safety Approvals	UL/cUL 60950-1 recognition(UL certificate), IEC/EN 60950-1(CB-report)				
	ANSI/AAMI ES60601-1 1xMOPP & 2xMOOP recognition(UL certificate), IEC/EN 60601-1 3.2 Edition(CB-report)				

General Specifications					
Parameter	Conditions	Min.	Typ.	Max.	Unit
Switching Frequency		---	150	---	kHz
MTBF(calculated)	MIL-HDBK-217F@25°C, Ground Benign	1,000,000	---	---	Hours

EMC Specifications				
Parameter	Standards & Level			Performance
	EMI	Conduction	EN 55011, EN 55032, EN 61000-6-3	
Radiation		EN 61000-6-4		
EMS	EN 60601-1-2 4 <sup>th</sup> , EN 55035, EN 61000-6-1, EN 61000-6-2			
	ESD	Direct discharge	Indirect discharge HCP & VCP	A
		EN 61000-4-2 Air ± 15kV	Contact ± 8kV	A
	Radiated immunity	EN 61000-4-3 10V/m		A
	Fast transient	EN 61000-4-4 ±2kV		A
	Surge	EN 61000-4-5 ±1kV		A
	Conducted immunity	EN 61000-4-6 10Vrms		A
PFMF	EN 61000-4-8 100A/m.1000A/m(1 sec)		A	

Environmental Specifications				
Parameter	Min.	Max.	Unit	
Operating Ambient Temperature Range (See Power Derating Curve)	-40	+85	°C	
Case Temperature	---	+100	°C	
Storage Temperature Range	-50	+125	°C	
Humidity (non condensing)	---	95	% rel. H	
Lead Temperature (1.5mm from case for 10Sec.)	---	260	°C	

Notes
1 Specifications typical at Ta=+25°C, resistive load, nominal input voltage and rated output current unless otherwise noted.
2 Transient recovery time is measured to within 1% error band for a step change in output load of 75% to 100%.
3 These power converters require a minimum output loading to maintain specified regulation, operation under no-load conditions will not damage these modules; however, they may not meet all specifications listed.
4 We recommend to protect the converter by a slow blow fuse in the input supply line.
5 Other input and output voltage may be available, please contact MINMAX.
6 Specifications are subject to change without notice.
7 The repeated high voltage isolation testing of the converter can degrade isolation capability, to a lesser or greater degree depending on materials, construction, environment and reflow solder process. Any material is susceptible to eventual chemical degradation when subject to very high applied voltages thus implying that the number of tests should be strictly limited. We therefore strongly advise against repeated high voltage isolation testing, but if it is absolutely required, that the voltage be reduced by 20% from specified test voltage. Furthermore, the high voltage isolation capability after reflow solder process should be evaluated as it is applied on system.

**Characteristic Curves**

All test conditions are at 25°C The figures are identical for MIHW2022

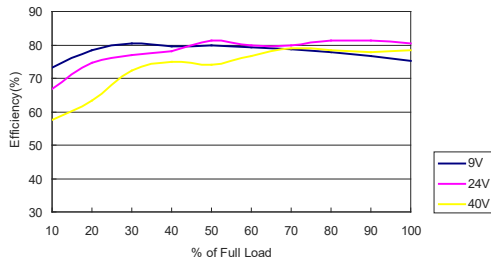

Efficiency Versus Output Current

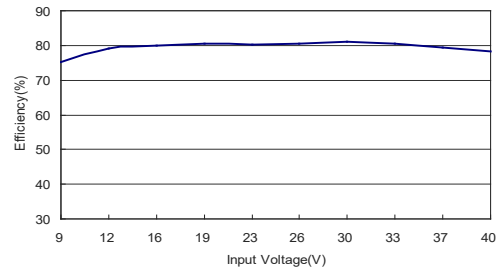

Efficiency Versus Input Voltage  
Full Load

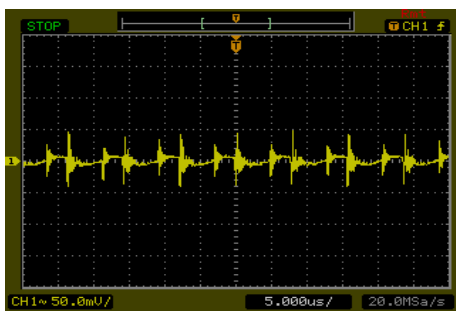

Typical Output Ripple and Noise  
 $V_{in}=V_{in,nom}$ ; Full Load

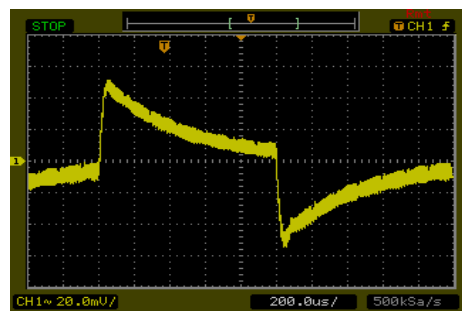

Transient Response to Dynamic Load Change  
from 100% to 75% of Full Load ;  $V_{in}=V_{in,nom}$

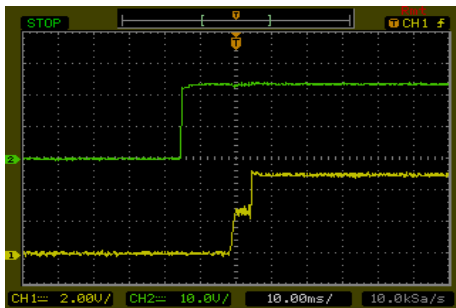

Typical Input Start-Up and Output Rise Characteristic  
 $V_{in}=V_{in,nom}$ ; Full Load

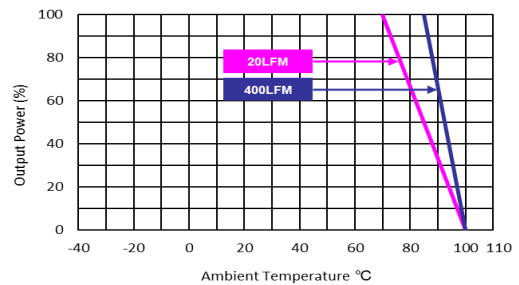

Derating Output Power Versus Ambient Temperature and Airflow  
 $V_{in}=V_{in,nom}$

**Characteristic Curves**

All test conditions are at 25°C The figures are identical for MIHW2023

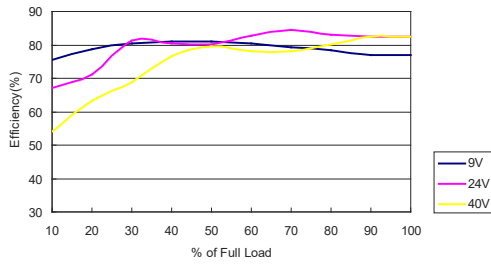

Efficiency Versus Output Current

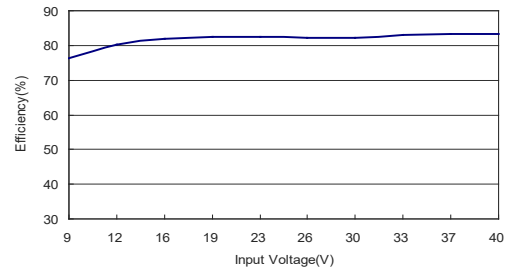

Efficiency Versus Input Voltage  
Full Load

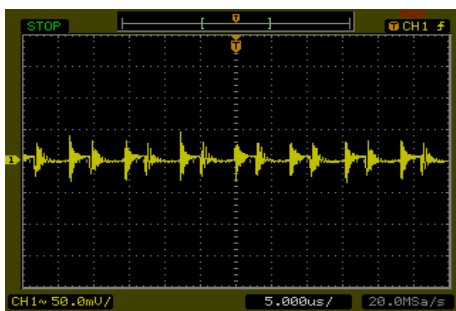

Typical Output Ripple and Noise  
 $V_{in}=V_{in,nom}$ ; Full Load

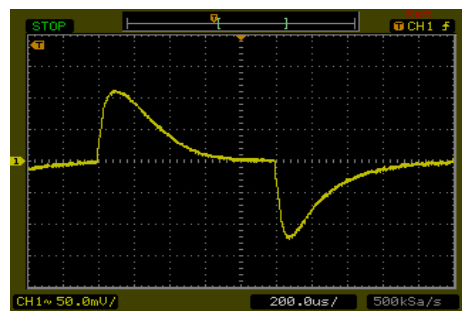

Transient Response to Dynamic Load Change  
from 100% to 75% of Full Load ;  $V_{in}=V_{in,nom}$

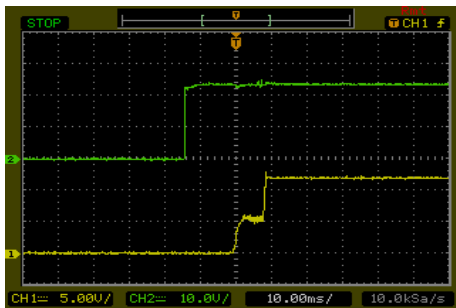

Typical Input Start-Up and Output Rise Characteristic  
 $V_{in}=V_{in,nom}$ ; Full Load

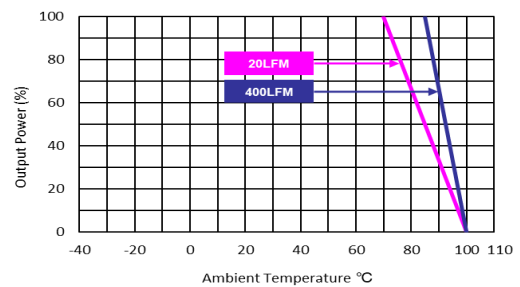

Derating Output Power Versus Ambient Temperature and Airflow  
 $V_{in}=V_{in,nom}$

**Characteristic Curves**

All test conditions are at 25°C. The figures are identical for MIHW2026

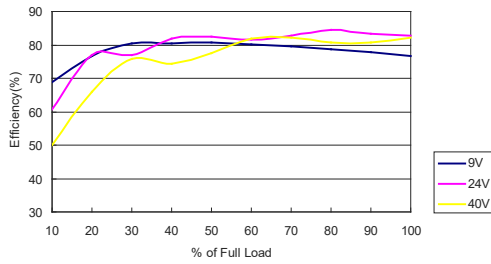

Efficiency Versus Output Current

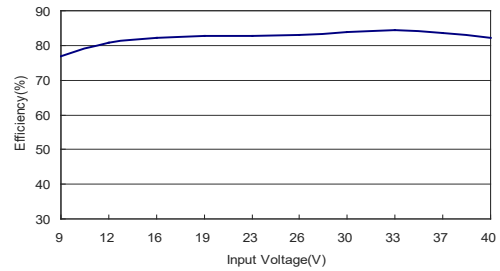

Efficiency Versus Input Voltage  
Full Load

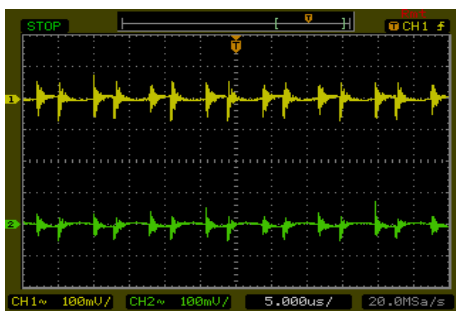

Typical Output Ripple and Noise  
 $V_{in}=V_{in,nom}$ ; Full Load

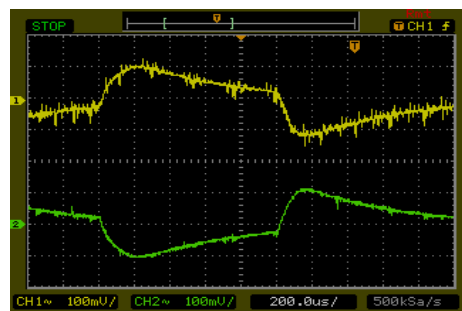

Transient Response to Dynamic Load Change  
from 100% to 75% of Full Load;  $V_{in}=V_{in,nom}$

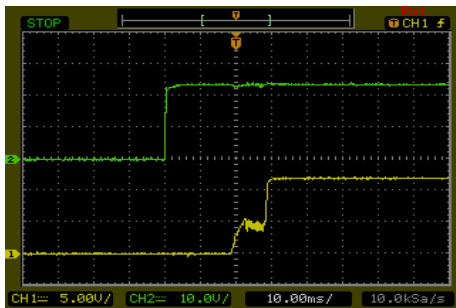

Typical Input Start-Up and Output Rise Characteristic  
 $V_{in}=V_{in,nom}$ ; Full Load

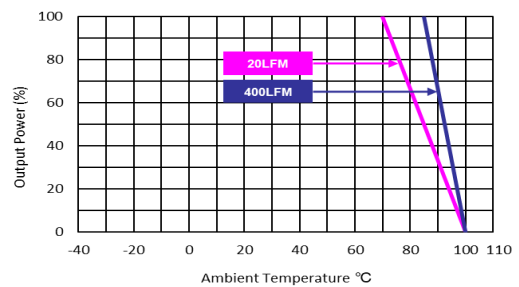

Derating Output Power Versus Ambient Temperature and Airflow  
 $V_{in}=V_{in,nom}$

**Characteristic Curves**

All test conditions are at 25°C. The figures are identical for MIHW2027

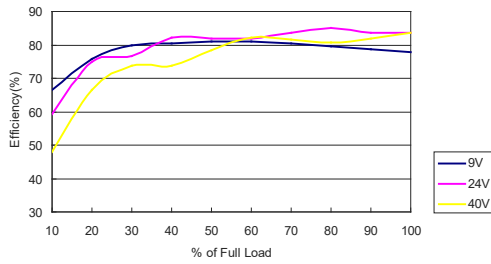

Efficiency Versus Output Current

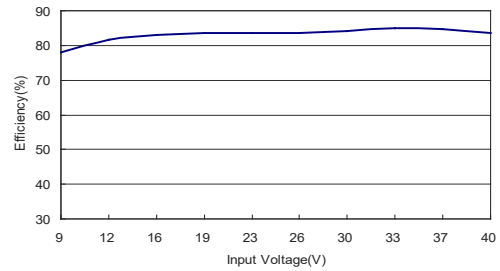

Efficiency Versus Input Voltage  
Full Load

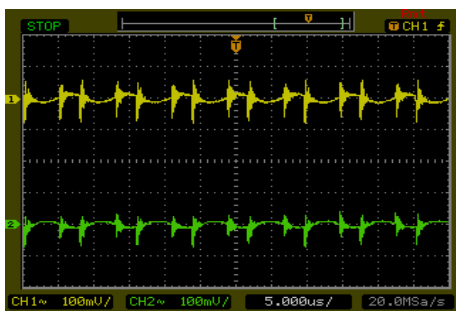

Typical Output Ripple and Noise  
 $V_{in}=V_{in,nom}$ ; Full Load

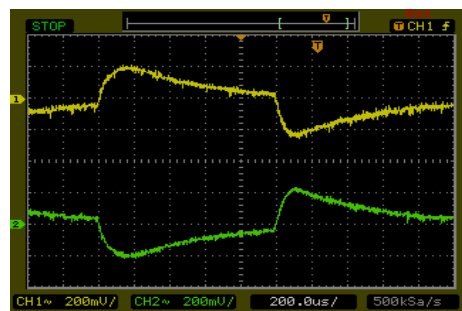

Transient Response to Dynamic Load Change  
from 100% to 75% of Full Load;  $V_{in}=V_{in,nom}$

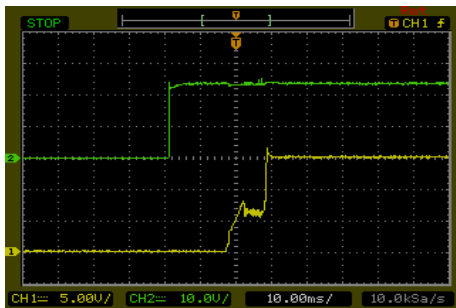

Typical Input Start-Up and Output Rise Characteristic  
 $V_{in}=V_{in,nom}$ ; Full Load

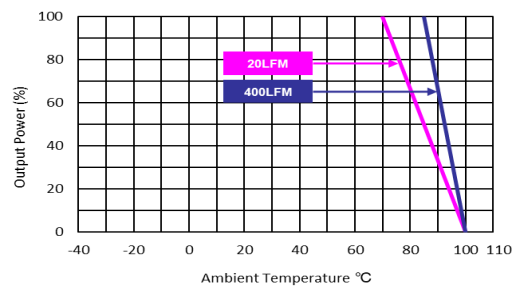

Derating Output Power Versus Ambient Temperature and Airflow  
 $V_{in}=V_{in,nom}$



**Characteristic Curves**

All test conditions are at 25°C The figures are identical for MIHW2032

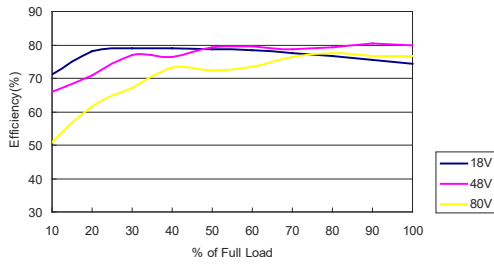

Efficiency Versus Output Current

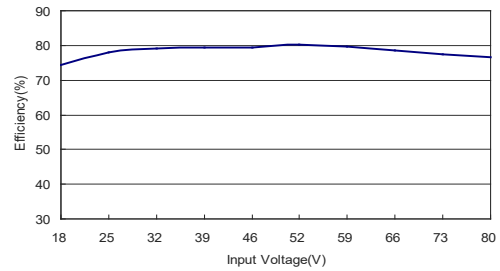

Efficiency Versus Input Voltage  
Full Load

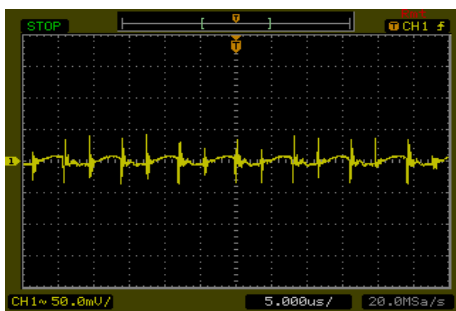

Typical Output Ripple and Noise  
 $V_{in}=V_{in,nom}$ ; Full Load

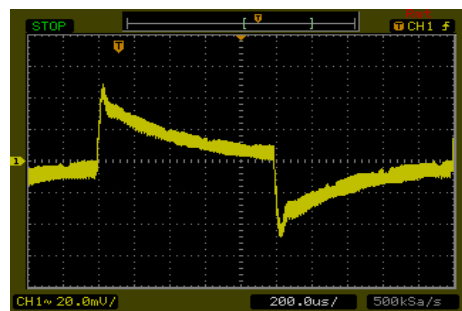

Transient Response to Dynamic Load Change  
from 100% to 75% of Full Load ;  $V_{in}=V_{in,nom}$

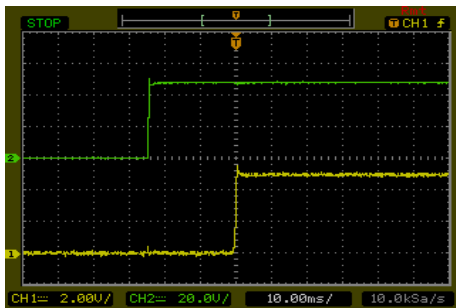

Typical Input Start-Up and Output Rise Characteristic  
 $V_{in}=V_{in,nom}$ ; Full Load

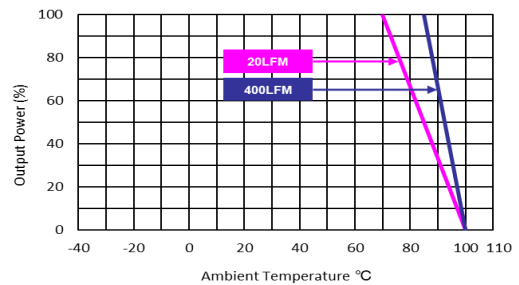

Derating Output Power Versus Ambient Temperature and Airflow  
 $V_{in}=V_{in,nom}$

**Characteristic Curves**

All test conditions are at 25°C The figures are identical for MIHW2033

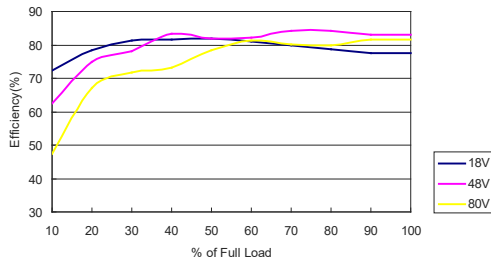

Efficiency Versus Output Current

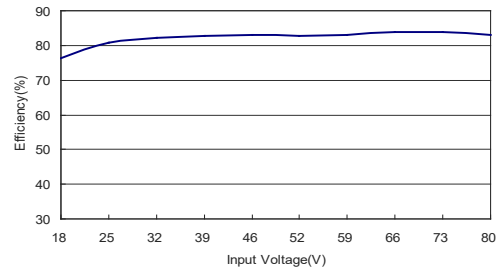

Efficiency Versus Input Voltage  
Full Load

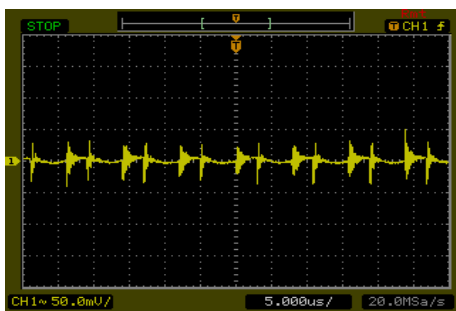

Typical Output Ripple and Noise  
 $V_{in}=V_{in,nom}$ ; Full Load

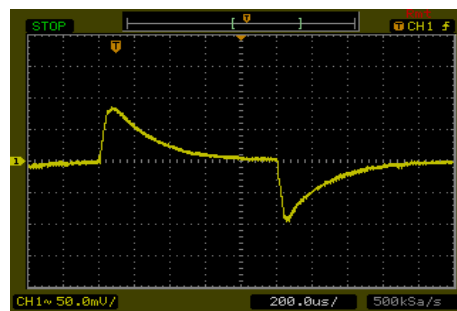

Transient Response to Dynamic Load Change  
from 100% to 75% of Full Load ;  $V_{in}=V_{in,nom}$

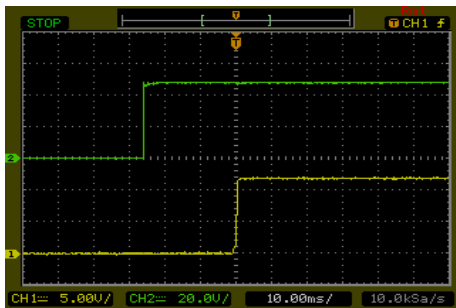

Typical Input Start-Up and Output Rise Characteristic  
 $V_{in}=V_{in,nom}$ ; Full Load

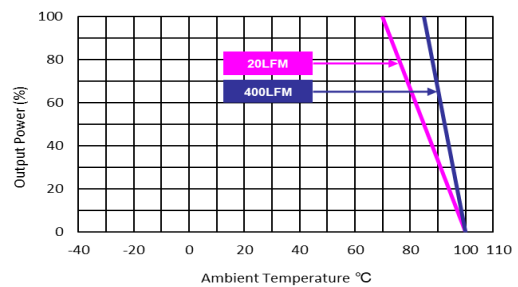

Derating Output Power Versus Ambient Temperature and Airflow  
 $V_{in}=V_{in,nom}$

**Characteristic Curves**

All test conditions are at 25°C The figures are identical for MIHW2036

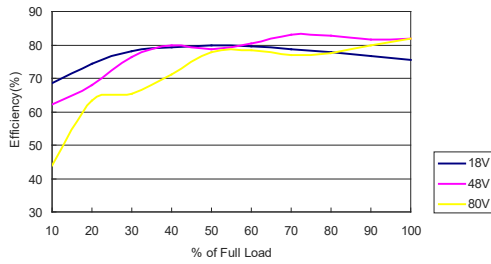

Efficiency Versus Output Current

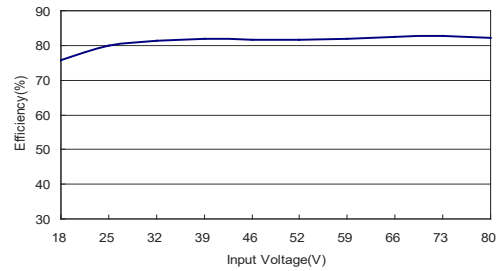

Efficiency Versus Input Voltage Full Load

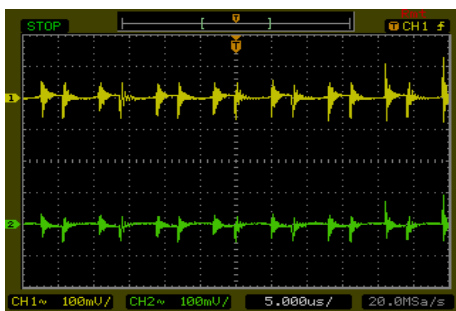

Typical Output Ripple and Noise  
 $V_{in}=V_{in,nom}$ ; Full Load

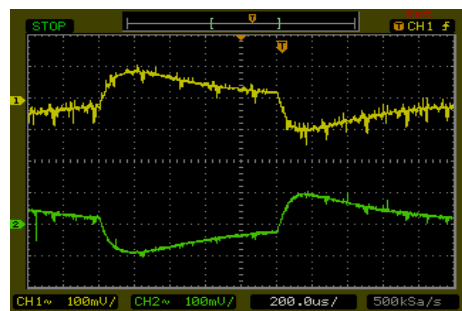

Transient Response to Dynamic Load Change  
from 100% to 75% of Full Load;  $V_{in}=V_{in,nom}$

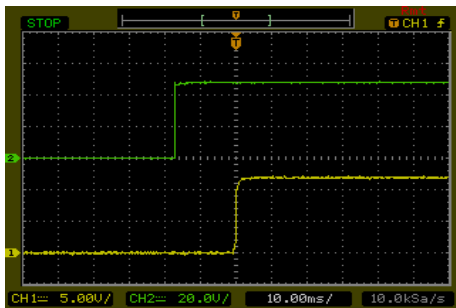

Typical Input Start-Up and Output Rise Characteristic  
 $V_{in}=V_{in,nom}$ ; Full Load

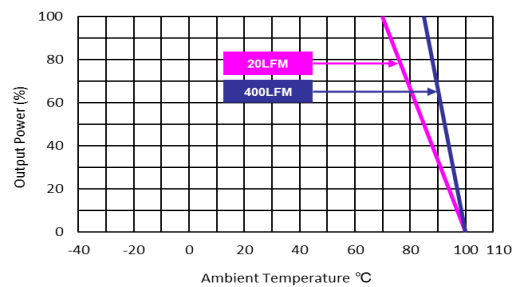

Derating Output Power Versus Ambient Temperature and Airflow  
 $V_{in}=V_{in,nom}$

**Characteristic Curves**

All test conditions are at 25°C The figures are identical for MIHW2037

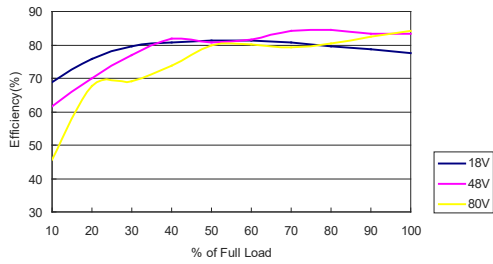

Efficiency Versus Output Current

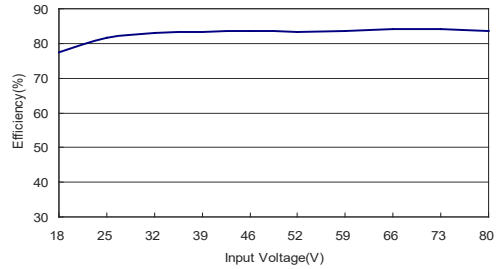

Efficiency Versus Input Voltage  
Full Load

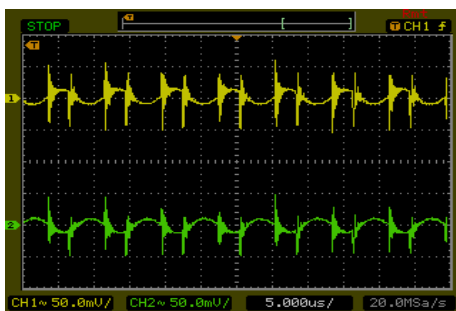

Typical Output Ripple and Noise  
 $V_{in}=V_{in,nom}$ ; Full Load

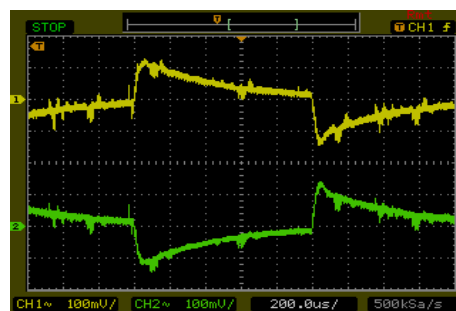

Transient Response to Dynamic Load Change  
from 100% to 75% of Full Load ;  $V_{in}=V_{in,nom}$

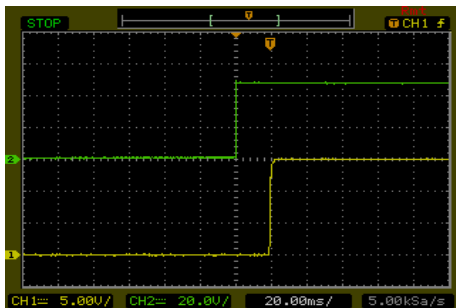

Typical Input Start-Up and Output Rise Characteristic  
 $V_{in}=V_{in,nom}$ ; Full Load

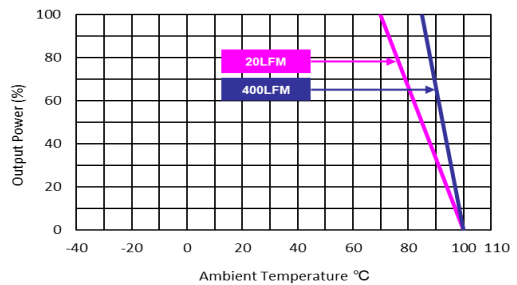

Derating Output Power Versus Ambient Temperature and Airflow  
 $V_{in}=V_{in,nom}$

**Characteristic Curves**

All test conditions are at 25°C The figures are identical for MIHW2042

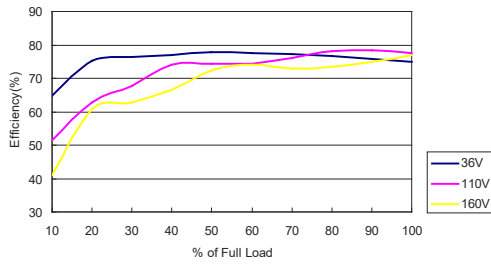

Efficiency Versus Output Current

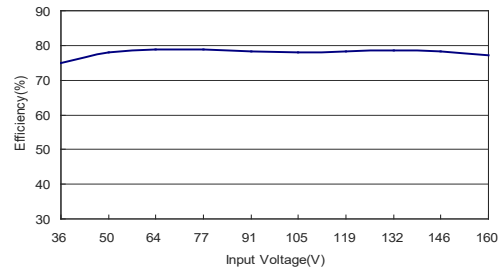

Efficiency Versus Input Voltage Full Load

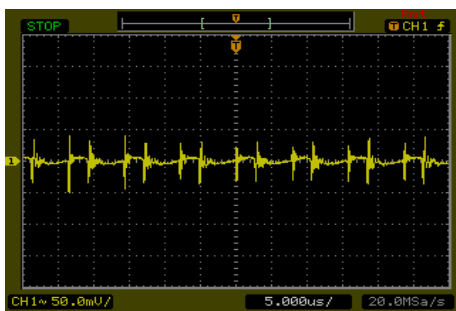

Typical Output Ripple and Noise  
 $V_{in}=V_{in,nom}$ ; Full Load

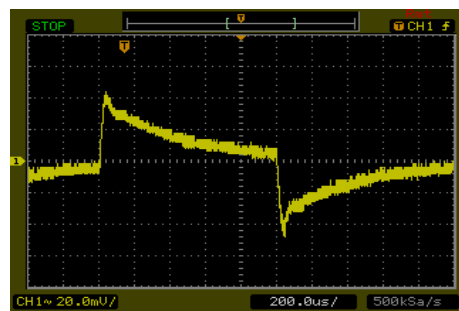

Transient Response to Dynamic Load Change  
from 100% to 75% of Full Load ;  $V_{in}=V_{in,nom}$

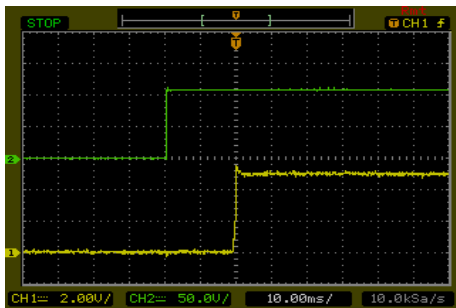

Typical Input Start-Up and Output Rise Characteristic  
 $V_{in}=V_{in,nom}$ ; Full Load

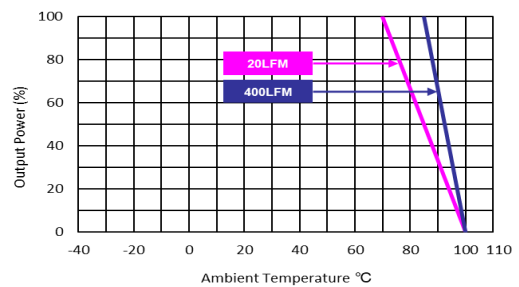

Derating Output Power Versus Ambient Temperature and Airflow  
 $V_{in}=V_{in,nom}$

**Characteristic Curves**

All test conditions are at 25°C. The figures are identical for MIHW2043

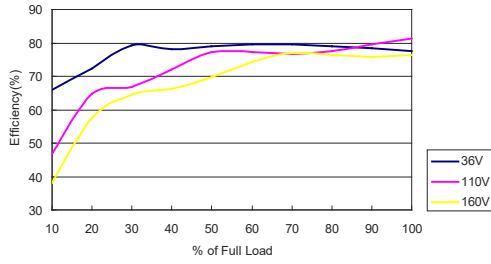

Efficiency Versus Output Current

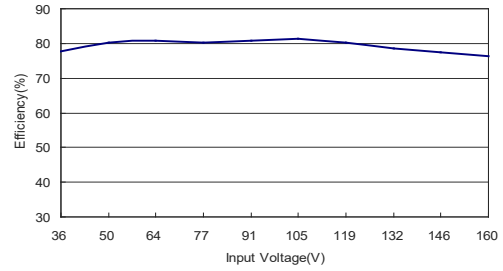

Efficiency Versus Input Voltage  
Full Load

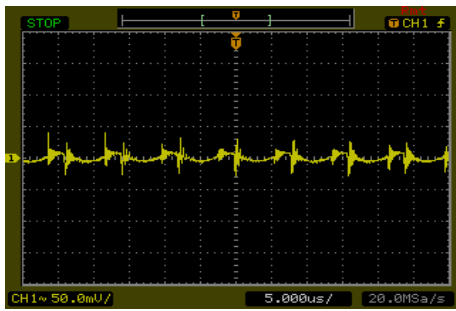

Typical Output Ripple and Noise  
 $V_{in} = V_{in, nom}$ ; Full Load

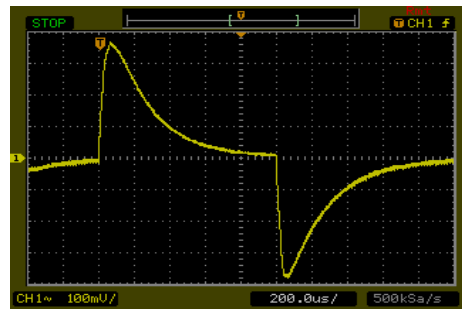

Transient Response to Dynamic Load Change  
from 100% to 75% of Full Load;  $V_{in} = V_{in, nom}$

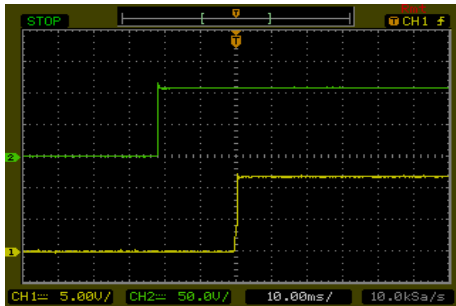

Typical Input Start-Up and Output Rise Characteristic  
 $V_{in} = V_{in, nom}$ ; Full Load

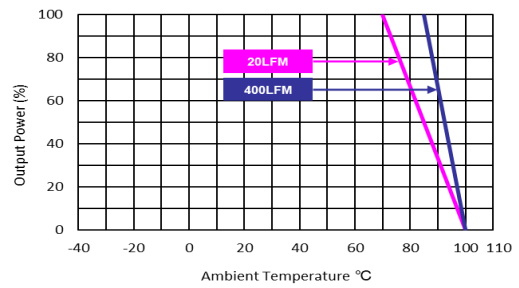

Derating Output Power Versus Ambient Temperature and Airflow  
 $V_{in} = V_{in, nom}$

**Characteristic Curves**

All test conditions are at 25°C. The figures are identical for MIHW2046

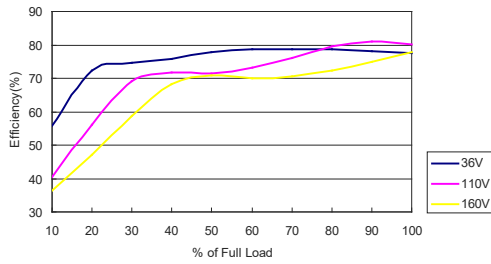

Efficiency Versus Output Current

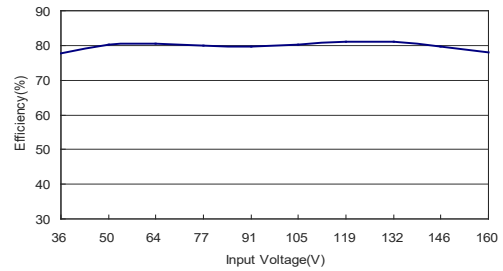

Efficiency Versus Input Voltage Full Load

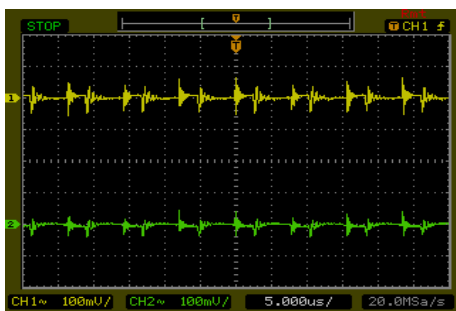

Typical Output Ripple and Noise  
 $V_{in}=V_{in,nom}$ ; Full Load

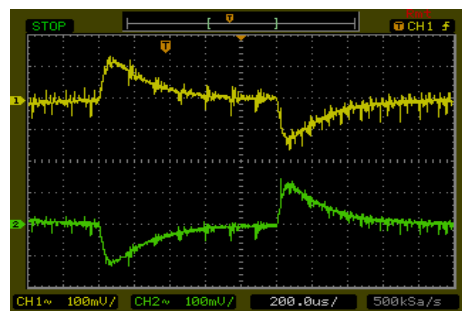

Transient Response to Dynamic Load Change  
from 100% to 75% of Full Load;  $V_{in}=V_{in,nom}$

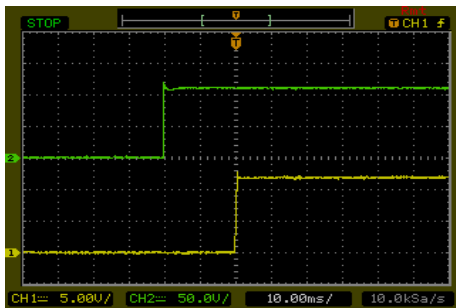

Typical Input Start-Up and Output Rise Characteristic  
 $V_{in}=V_{in,nom}$ ; Full Load

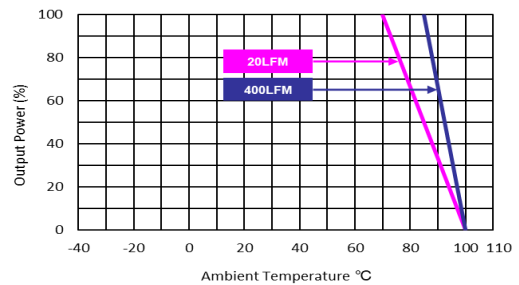

Derating Output Power Versus Ambient Temperature and Airflow  
 $V_{in}=V_{in,nom}$

**Characteristic Curves**

All test conditions are at 25°C. The figures are identical for MIHW2047

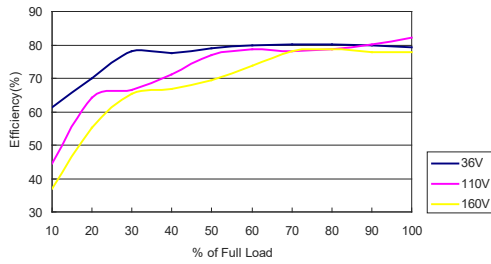

Efficiency Versus Output Current

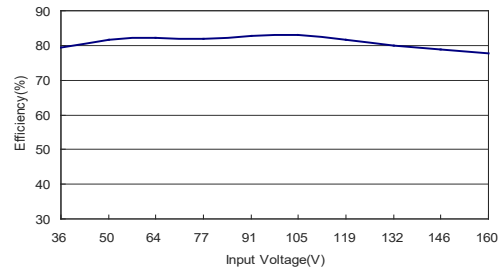

Efficiency Versus Input Voltage Full Load

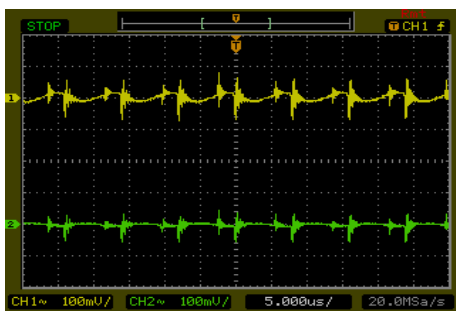

Typical Output Ripple and Noise  
 $V_{in}=V_{in,nom}$ ; Full Load

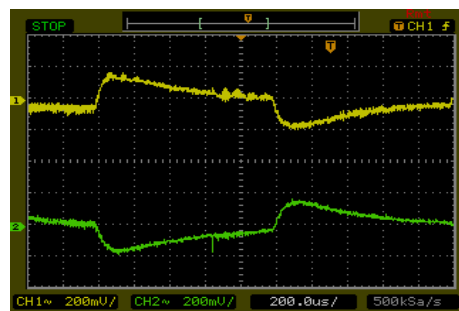

Transient Response to Dynamic Load Change  
from 100% to 75% of Full Load;  $V_{in}=V_{in,nom}$

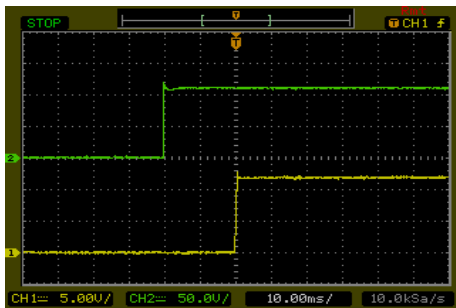

Typical Input Start-Up and Output Rise Characteristic  
 $V_{in}=V_{in,nom}$ ; Full Load

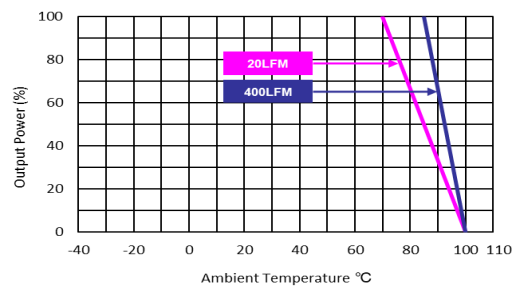

Derating Output Power Versus Ambient Temperature and Airflow  
 $V_{in}=V_{in,nom}$



### Package Specifications

#### Mechanical Dimensions

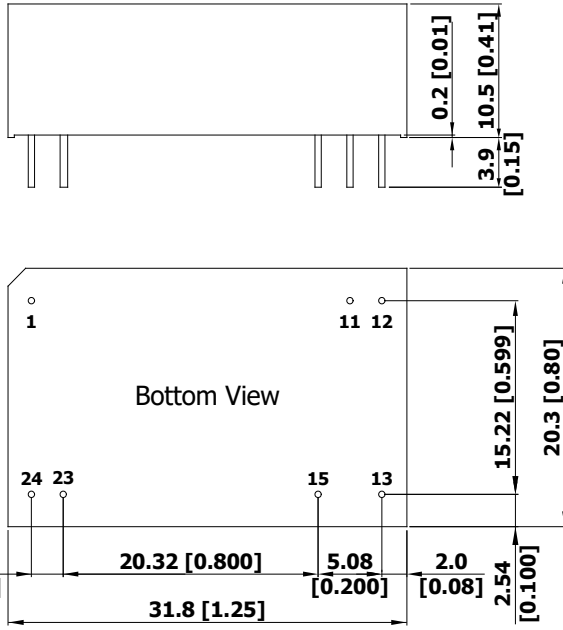

#### Pin Connections

Pin	Single Output	Dual Output	Diameter mm (inches)
1	+Vin	+Vin	Ø 0.6 [0.024]
11	No Pin	Common	Ø 0.6 [0.024]
12	-Vout	No Pin	Ø 0.6 [0.024]
13	+Vout	-Vout	Ø 0.6 [0.024]
15	No Pin	+Vout	Ø 0.6 [0.024]
23	-Vin	-Vin	Ø 0.6 [0.024]
24	-Vin	-Vin	Ø 0.6 [0.024]

- ▶ All dimensions in mm (inches)
- ▶ Tolerance: X.X±0.25 (X.XX±0.01)  
X.XX±0.13 (X.XXX±0.005)
- ▶ Pin diameter tolerance: X.X±0.05 (X.XXX±0.002)

### Physical Characteristics

Case Size	: 31.8x20.3x10.5mm (1.25x0.8x0.41 inches)
Case Material	: Plastic resin (flammability to UL 94V-0 rated)
Pin Material	: Copper Alloy
Weight	: 13.3g

### Recommended Pad Layout for Single & Dual Output Converter

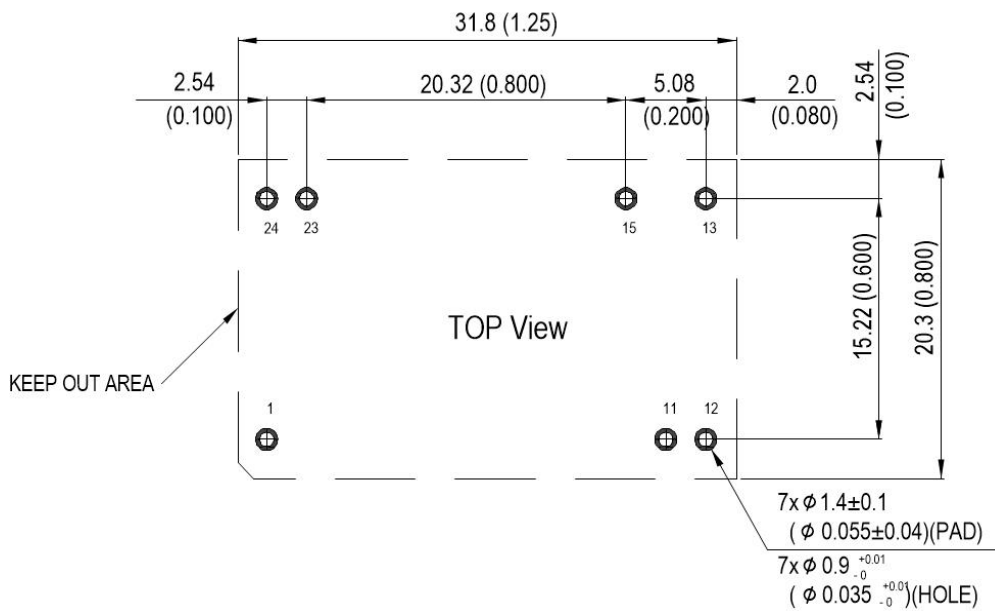

### Test Setup

#### Input Reflected-Ripple Current Test Setup

Input reflected-ripple current is measured with an inductor  $L_{in}$  ( $4.7\mu H$ ) and  $C_{in}$  ( $220\mu F$ ,  $ESR < 1.0\Omega$  at  $100\text{ kHz}$ ) to simulate source impedance. Capacitor  $C_{in}$  offsets possible battery impedance. Current ripple is measured at the input terminals of the module, measurement bandwidth is  $0\text{--}500\text{ kHz}$ .

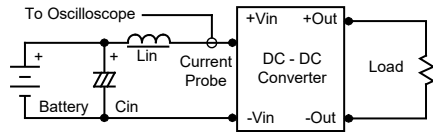

#### Peak-to-Peak Output Noise Measurement Test

Use a  $C_{out}$   $0.47\mu F$  ceramic capacitor. Scope measurement should be made by using a BNC socket, measurement bandwidth is  $0\text{--}20\text{ MHz}$ . Position the load between  $50\text{ mm}$  and  $75\text{ mm}$  from the DC-DC Converter.

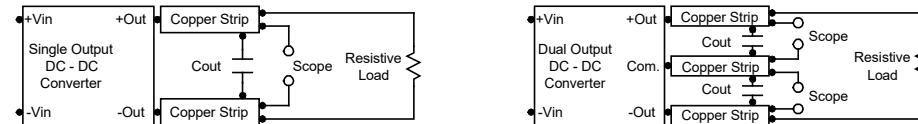

### Technical Notes

#### Overload Protection

To provide protection in a fault (output overload) condition, the unit is equipped with internal current limiting circuitry and can endure current limiting for an unlimited duration. At the point of current-limit inception, the unit shifts from voltage control to current control. The unit operates normally once the output current is brought back into its specified range.

#### Input Source Impedance

The power module should be connected to a low ac-impedance input source. Highly inductive source impedances can affect the stability of the power module. In applications where power is supplied over long lines and output loading is high, it may be necessary to use a capacitor on the input to insure startup. By using a good quality low Equivalent Series Resistance ( $ESR < 1.0\Omega$  at  $100\text{ kHz}$ ) capacitor of a  $4.7\mu F$  for the  $24\text{V}$  input devices, a  $2.2\mu F$  for the  $48\text{V}$  devices and a  $1\mu F$  for the  $110\text{V}$  devices, capacitor mounted close to the power module helps ensure stability of the unit.

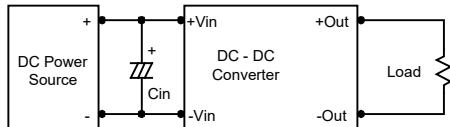

#### Output Ripple Reduction

A good quality low ESR capacitor placed as close as practicable across the load will give the best ripple and noise performance. To reduce output ripple, it is recommended to use  $3.3\mu F$  capacitors at the output.

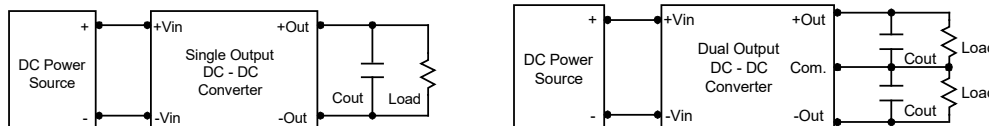

#### Maximum Capacitive Load

The MIHW2000 series has limitation of maximum connected capacitance on the output. The power module may operate in current limiting mode during start-up, affecting the ramp-up and the startup time. Connect capacitors at the point of load for best performance. The maximum capacitance can be found in the data sheet.

#### Thermal Considerations

Many conditions affect the thermal performance of the power module, such as orientation, airflow over the module and board spacing. To avoid exceeding the maximum temperature rating of the components inside the power module, the case temperature must be kept below  $100^\circ\text{C}$ . The derating curves are determined from measurements obtained in a test setup.

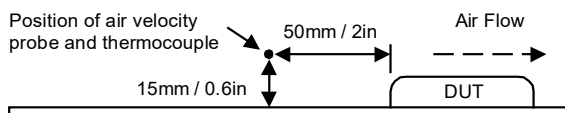

**Packaging Information for Tube**

Tube

Plug

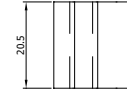
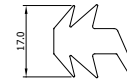
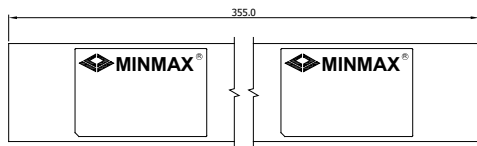
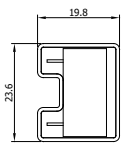

Unit: mm  
10 PCS per TUBE

**Wave Soldering Considerations**

Lead free wave solder profile

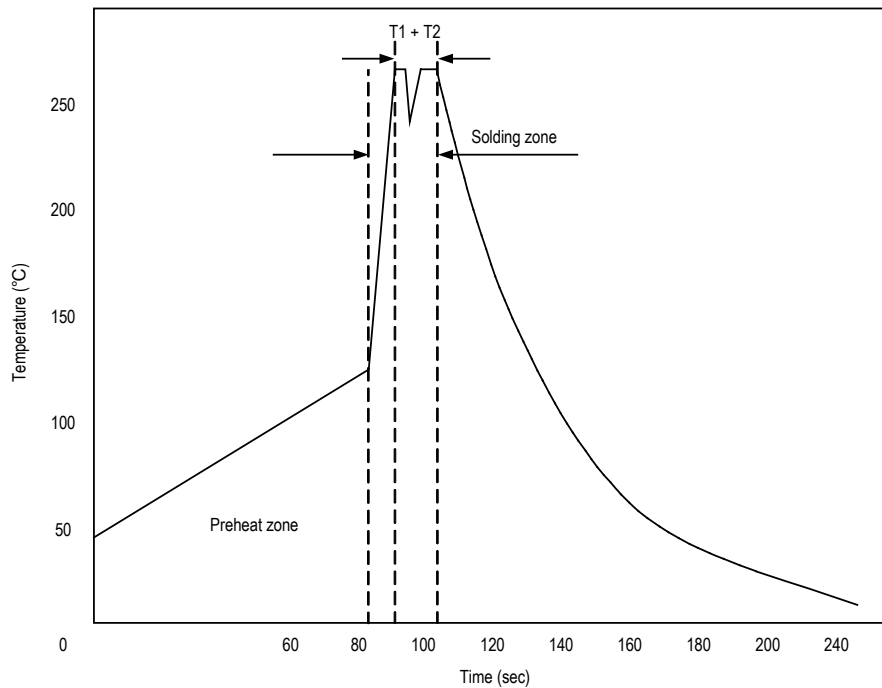

Zone	Reference Parameter
Preheat	Rise temp. speed : 3°C/sec max.
zone	Preheat temp. : 100~130°C
Actual	Peak temp. : 250~260°C
heating	Peak time(T1+T2) : 4~6 sec

**Hand Welding Parameter**

Reference Solder: Sn-Ag-Cu : Sn-Cu : Sn-Ag

Hand Welding: Soldering iron : Power 60W

Welding Time: 2~4 sec

Temp.: 380~400°C

**Part Number Structure**

M	I	H	W	202	2
Package Type DIP-24	I/O Isolation Voltage 4000 VAC	Ultra-wide 4:1 Input Voltage Range	Input Voltage Range		Output Voltage
			202: 9 ~ 40 VDC	2: 5 VDC	
			203: 18 ~ 80 VDC	3: 12 VDC	
			204: 36 ~ 160 VDC	6: ±12 VDC	
				7: ±15 VDC	

**MTBF and Reliability**

The MTBF of MIHW2000 series of DC-DC converters has been calculated using

MIL-HDBK 217F NOTICE2, Operating Temperature 25°C, Ground Benign.

Model	MTBF	Unit
MIHW2022	1,055,632	Hours
MIHW2023	1,105,583	
MIHW2026	1,085,776	
MIHW2027	1,091,465	
MIHW2032	1,044,168	
MIHW2033	1,093,016	
MIHW2036	1,072,386	
MIHW2037	1,073,653	
MIHW2042	1,023,541	
MIHW2043	1,070,435	
MIHW2046	1,051,746	
MIHW2047	1,053,630	