



**MINMAX<sup>®</sup>**

MJW25 Series

Electric Characteristic Note

# MJW25 Series EC Note

DC-DC CONVERTER 25W, Highest Power Density

## Features

- ▶ Smallest Encapsulated 25W Converter
- ▶ Ultra-compact 1" X 1" Package
- ▶ Wide 2:1 Input Voltage Range
- ▶ Fully Regulated Output Voltage
- ▶ Excellent Efficiency up to 90%
- ▶ I/O Isolation 1500 VDC
- ▶ Operating Ambient Temp. Range -40°C to +80°C
- ▶ No Min. Load Requirement
- ▶ Overload/Voltage and Short Circuit Protection
- ▶ Remote On/Off Control, Output Voltage Trim
- ▶ Shielded Metal Case with Insulated Baseplate
- ▶ UL/cUL/IEC/EN 62368-1(60950-1) Safety Approval & CE Marking

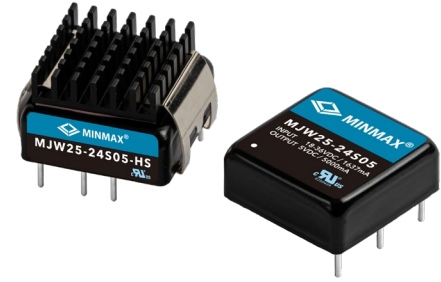

## Applications

- ▶ Distributed power architectures
- ▶ Workstations
- ▶ Computer equipment
- ▶ Communications equipment

## Product Overview

The MINMAX MJW25 series is the generation of high-performance DC-DC converter modules with very high power density. The product offers fully 25W in a shielded metal package with dimensions of just 1.0"x1.0"x0.4". All models provide wide 2:1 input range and tightly regulated output voltage. By state-of-the-art circuit topology a very high efficiency up to 90% could be achieved allowing an operating temperature range of -40°C to +80°C (with derating). These converters are qualified for demanding applications in battery operated equipment, instrumentation, data communication, industrial and many other space critical applications.

## Table of contents

Model Selection Guide .....	P2	External Output Trimming.....	P24
Input Specifications.....	P2	Test Setup.....	P25
Remote On/Off Control .....	P2	Technical Notes .....	P25
Output Specifications.....	P3	Remote On/Off Implementation.....	P26
General Specifications.....	P3	Packaging Information for Tube .....	P26
EMC Specifications.....	P3	Wave Soldering Considerations .....	P27
Environmental Specifications .....	P4	Hand Welding Parameter .....	P27
Characteristic Curves .....	P5	Part Number Structure .....	P28
Package Specifications .....	P23	MTBF and Reliability .....	P28
Recommended Pad Layout for Single & Dual Output Converter.....	P24		

Model Selection Guide									
Model Number	Input Voltage (Range)	Output Voltage	Output Current Max.	Input Current		Reflected Ripple Current	Over Voltage Protection	Max. capacitive Load	Efficiency (typ.)
				@Max. Load	@No Load				@Max. Load
	VDC	VDC	mA	mA(typ.)	mA(typ.)	mA (typ.)	VDC	μF	%
MJW25-12S033	12 (9 ~ 18)	3.3	6000	1900	75	80	3.9	10300	87
MJW25-12S05		5	5000	2340	85		6.2	6800	89
MJW25-12S12		12	2090	2350	80		15	1200	89
MJW25-12S15		15	1670	2350	80		18	750	89
MJW25-12D12		±12	±1040	2340	75		±15	680#	89
MJW25-12D15		±15	±840	2360	75		±18	380#	89
MJW25-24S033	24 (18 ~ 36)	3.3	6000	940	55	50	3.9	10300	88
MJW25-24S05		5	5000	1160	60		6.2	6800	90
MJW25-24S12		12	2090	1160	55		15	1200	90
MJW25-24S15		15	1670	1160	55		18	750	90
MJW25-24D12		±12	±1040	1170	50		±15	680#	89
MJW25-24D15		±15	±840	1180	50		±18	380#	89
MJW25-48S033	48 (36 ~ 75)	3.3	6000	470	35	30	3.9	10300	88
MJW25-48S05		5	5000	580	40		6.2	6800	90
MJW25-48S12		12	2090	580	35		15	1200	90
MJW25-48S15		15	1670	580	35		18	750	90
MJW25-48D12		±12	±1040	585	40		±15	680#	89
MJW25-48D15		±15	±840	590	40		±18	380#	89

# For each output

Input Specifications							
Parameter	Conditions / Model		Min.	Typ.	Max.	Unit	
Input Surge Voltage (100ms max.)	12V Input Models		-0.7	---	25	VDC	
	24V Input Models		-0.7	---	50		
	48V Input Models		-0.7	---	100		
Start-up Threshold Voltage	12V Input Models		---	---	9	VDC	
	24V Input Models		---	---	18		
	48V Input Models		---	---	36		
Input Polarity Protection	None						
Start-up Time	Power Up	Nominal Vin and Constant Resistive Load		---	---	30	ms
	Remote On/Off			---	---	30	ms
Input Filter	All Models			Internal LC Type			

Remote On/Off Control							
Parameter	Conditions	Min.	Typ.	Max.	Unit		
Converter On	3.5V ~ 12V or Open Circuit						
Converter Off	0V ~ 1.2V or Short Circuit						
Control Input Current (on)	Vctrl = 5.0V	---	---	0.5	mA		
Control Input Current (off)	Vctrl = 0V	---	---	-0.5	mA		
Control Common	Referenced to Negative Input						
Standby Input Current	Nominal Vin	---	3	---	mA		

Output Specifications						
Parameter	Conditions / Model		Min.	Typ.	Max.	Unit
Output Voltage Setting Accuracy			---	---	±1.0	%Vnom.
Output Voltage Balance	Dual Output, Balanced Loads		---	---	±2.0	%
Line Regulation	Vin=Min. to Max. @Full Load		---	---	±0.2	%
Load Regulation	Io=0% to 100%	Single Output	---	---	±0.2	%
		Dual Output	---	---	±1.0	%
Cross Regulation (Dual)	Asymmetrical load 25% / 100% FL		---	---	±5.0	%
Minimum Load	No minimum Load Requirement					
Ripple & Noise	0-20 MHz Bandwidth	3.3V & 5V Models <sub>(3)</sub>	---	---	100	mV <sub>P-P</sub>
		12V, 15V & Dual Models <sub>(3)</sub>	---	---	150	mV <sub>P-P</sub>
Transient Recovery Time	25% Load Step Change <sub>(2)</sub>		---	250	---	μsec
Transient Response Deviation			---	±3	±5	%
Temperature Coefficient			---	---	±0.02	%/°C
Trim Up / Down Range (See Page 24)	% of Nominal Output Voltage		---	---	±10	%
Over Load Protection	Current Limitation at 150% typ. of Iout max., Hiccup					
Short Circuit Protection	Continuous, Automatic Recovery (Hiccup Mode 0.7Hz typ.)					

General Specifications						
Parameter	Conditions		Min.	Typ.	Max.	Unit
I/O Isolation Voltage	60 Seconds		1500	---	---	VDC
	1 Second		1800	---	---	VDC
I/O Isolation Resistance	500 VDC		1000	---	---	MΩ
I/O Isolation Capacitance	100kHz, 1V		---	---	2000	pF
Switching Frequency			---	285	---	kHz
MTBF(calculated)	MIL-HDBK-217F@25°C, Ground Benign		313,300			Hours
Safety Approvals	UL/cUL 60950-1 recognition(CSA certificate), IEC/EN 60950-1(CB-report)					
	UL/cUL 62368-1 recognition(UL certificate), IEC/EN 62368-1(CB-report)					

EMC Specifications				
Parameter	Standards & Level			Performance
EMI <sub>(6)</sub>	Conduction	EN 55032	With external components	Class A
	Radiation			
EMS <sub>(6)</sub>	EN 55035			
	ESD	EN61000-4-2 Air ± 8kV, Contact ±6kV		A
	Radiated immunity	EN 61000-4-3 10V/m		A
	Fast transient	EN 61000-4-4 ±2kV		A
	Surge	EN 61000-4-5 ±1kV		A
	Conducted immunity	EN 61000-4-6 10Vrms		A

Environmental Specifications						
Parameter	Conditions / Model	Min.	Max.		Unit	
			without Heatsink	with Heatsink		
Operating Ambient Temperature Range Nominal Vin, Load 100% Inom. (for Power Derating see relative Derating Curves)	MJW25-24S033, MJW25-48S033	-40	57	65	°C	
	MJW25-24S05, MJW25-24S12 MJW25-24S15, MJW25-48S05 MJW25-48S12, MJW25-48S15		56	64		
	MJW25-12S033		53	61		
	MJW25-12S05, MJW25-12S12, MJW25-12S15 MJW25-12D12, MJW25-12D15 MJW25-24D12, MJW25-24D15 MJW25-48D12, MJW25-48D15		50	59		
Thermal Impedance	20LFM Convection without Heatsink	17.6	---	---	°C/W	
	20LFM Convection with Heatsink	14.8	---	---	°C/W	
	100LFM Convection without Heatsink	13.6	---	---	°C/W	
	100LFM Convection with Heatsink	8.5	---	---	°C/W	
	200LFM Convection without Heatsink	11.8	---	---	°C/W	
	200LFM Convection with Heatsink	6.5	---	---	°C/W	
	400LFM Convection without Heatsink	8.8	---	---	°C/W	
	400LFM Convection with Heatsink	4.3	---	---	°C/W	
Case Temperature		---	+105	---	°C	
Storage Temperature Range		-50	+125	---	°C	
Humidity (non condensing)		---	95	---	% rel. H	
RFI	Six-Sided Shielded, Metal Case					
Lead Temperature (1.5mm from case for 10Sec.)		---	260	---	°C	

Notes	
1	Specifications typical at Ta=+25°C, resistive load, nominal input voltage, rated output current unless otherwise noted.
2	Transient recovery time is measured to within 1% error band for a step change in output load of 75% to 100%.
3	Ripple & Noise measurement with a 1µF/50V MLCC and a 10µF Tantalum Capacitor.
4	We recommend to protect the converter by a slow blow fuse in the input supply line.
5	Other input and output voltage may be available, please contact MINMAX
6	The external components might be required to meet EMI/EMS standard for some of test items. Please contact MINMAX for the solution in detail.
7	Specifications are subject to change without notice.
8	The repeated high voltage isolation testing of the converter can degrade isolation capability, to a lesser or greater degree depending on materials, construction, environment and reflow solder process. Any material is susceptible to eventual chemical degradation when subject to very high applied voltages thus implying that the number of tests should be strictly limited. We therefore strongly advise against repeated high voltage isolation testing, but if it is absolutely required, that the voltage be reduced by 20% from specified test voltage. Furthermore, the high voltage isolation capability after reflow solder process should be evaluated as it is applied on system.

**Characteristic Curves**

All test conditions are at 25°C The figures are identical for MJW25-12S033

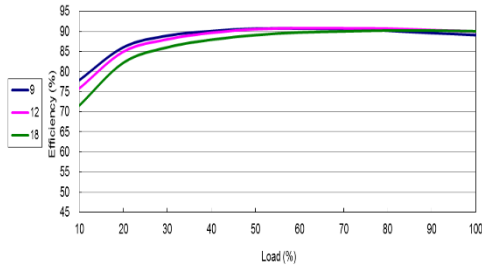

Efficiency Versus Output Current

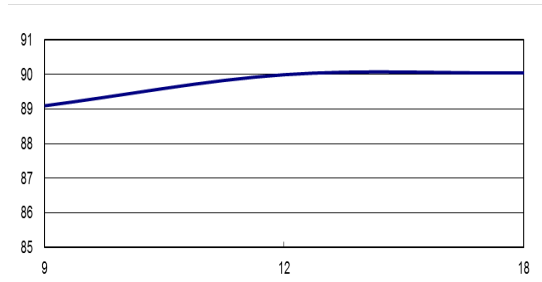

Efficiency Versus Input Voltage Full Load

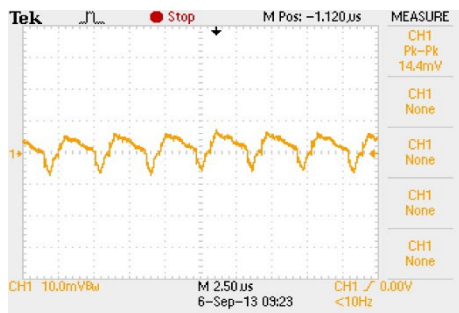

Typical Output Ripple and Noise.  
 $V_{in}=V_{in\ nom}$ ; Full Load

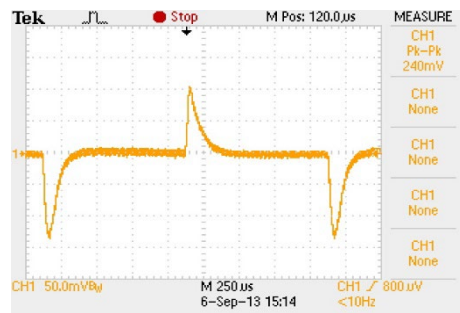

Transient Response to Dynamic Load Change  
from 100% to 75% of Full Load ;  $V_{in}=V_{in\ nom}$

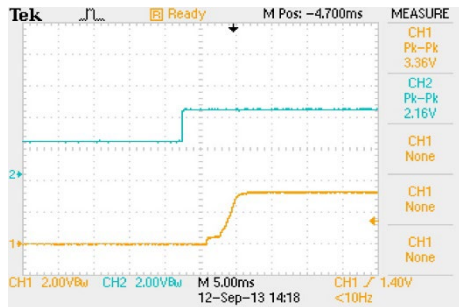

ON/OFF Voltage Start-Up and Output Rise Characteristic  
 $V_{in}=V_{in\ nom}$ ; Full Load

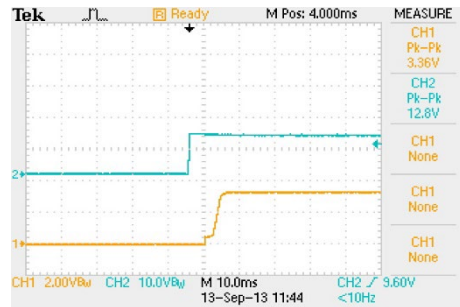

Typical Input Start-Up and Output Rise Characteristic  
 $V_{in}=V_{in\ nom}$ ; Full Load

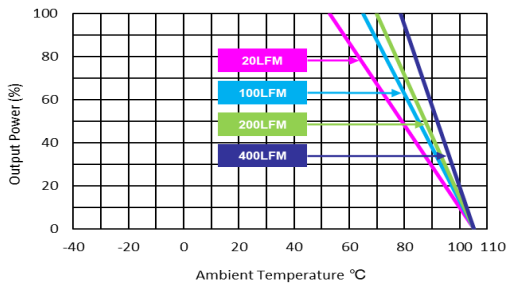

Derating Output Power Versus Ambient Temperature  
 $V_{in}=V_{in\ nom}$



**Characteristic Curves**

All test conditions are at 25°C The figures are identical for MJW25-12S05

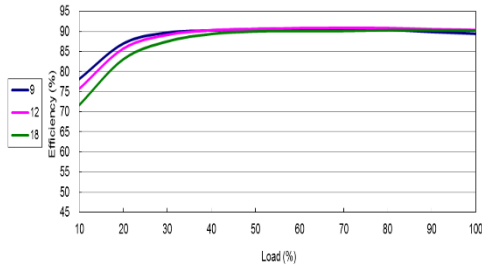

Efficiency Versus Output Current

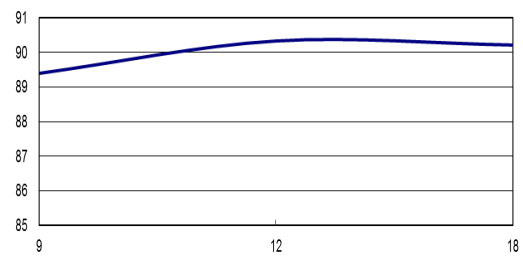

Efficiency Versus Input Voltage Full Load



Typical Output Ripple and Noise.  
 $V_{in}=V_{in\ nom}$ ; Full Load

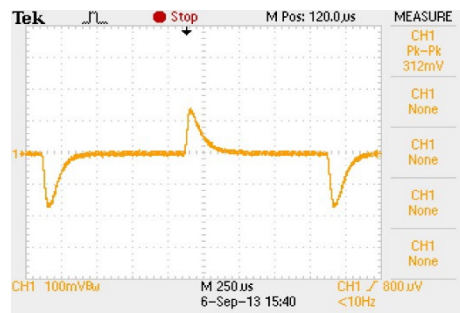

Transient Response to Dynamic Load Change  
from 100% to 75% of Full Load ;  $V_{in}=V_{in\ nom}$

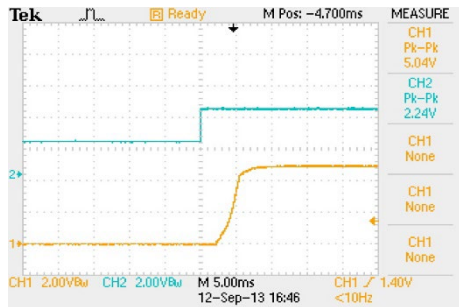

ON/OFF Voltage Start-Up and Output Rise Characteristic  
 $V_{in}=V_{in\ nom}$ ; Full Load

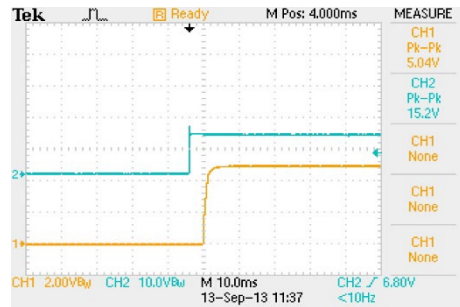

Typical Input Start-Up and Output Rise Characteristic  
 $V_{in}=V_{in\ nom}$ ; Full Load

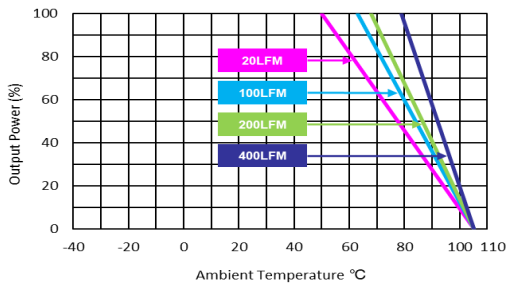

Derating Output Power Versus Ambient Temperature  
 $V_{in}=V_{in\ nom}$

**Characteristic Curves**

All test conditions are at 25°C The figures are identical for MJW25-12S12

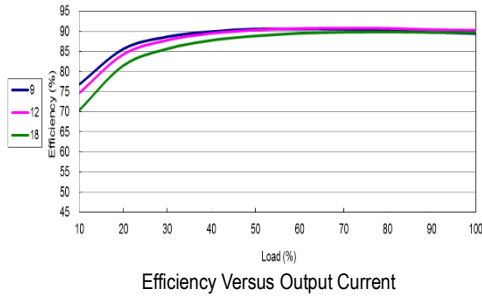

Efficiency Versus Output Current

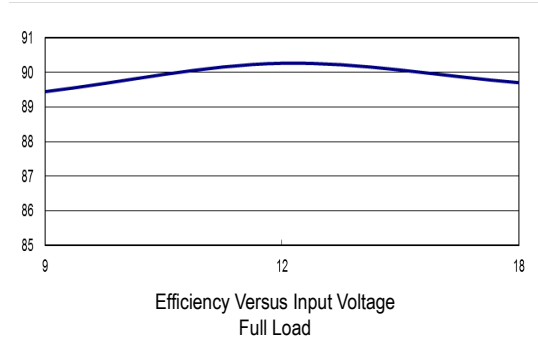

Efficiency Versus Input Voltage Full Load

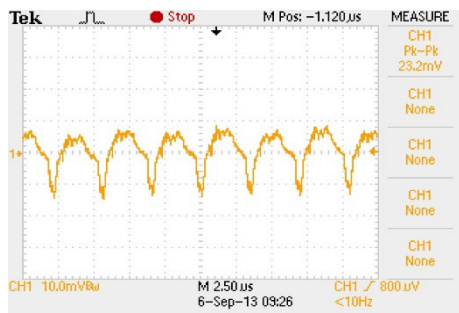

Typical Output Ripple and Noise.  
 $V_{in}=V_{in\ nom}$ ; Full Load

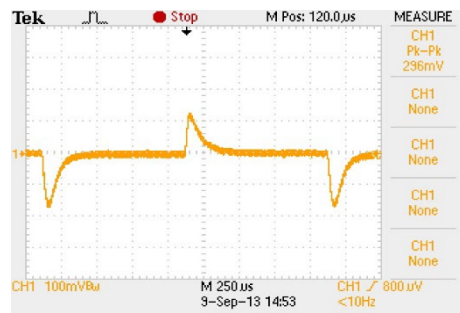

Transient Response to Dynamic Load Change  
from 100% to 75% of Full Load ;  $V_{in}=V_{in\ nom}$

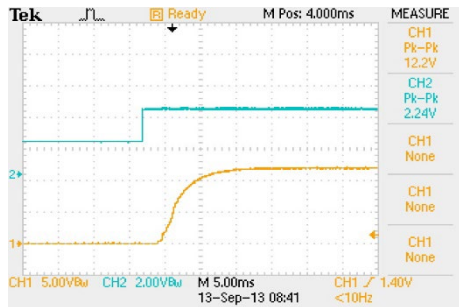

ON/OFF Voltage Start-Up and Output Rise Characteristic  
 $V_{in}=V_{in\ nom}$ ; Full Load

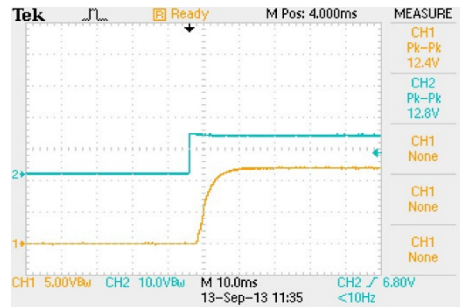

Typical Input Start-Up and Output Rise Characteristic  
 $V_{in}=V_{in\ nom}$ ; Full Load

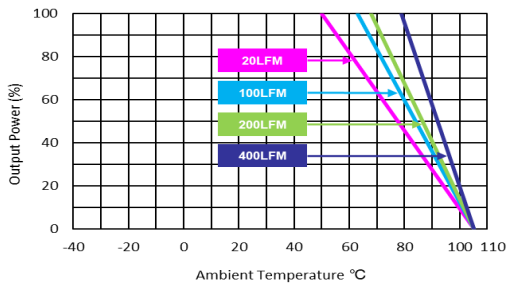

Derating Output Power Versus Ambient Temperature  
 $V_{in}=V_{in\ nom}$



**Characteristic Curves**

All test conditions are at 25°C The figures are identical for MJW25-12S15

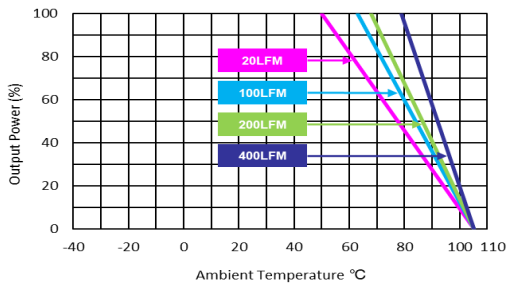
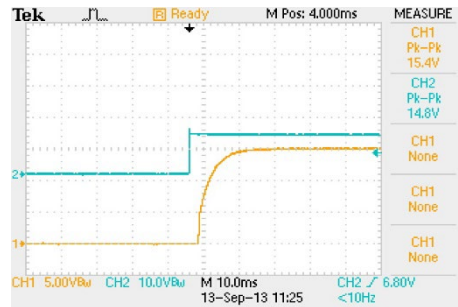
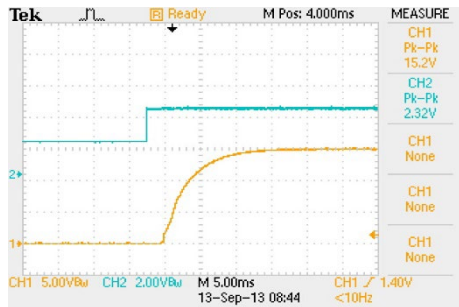
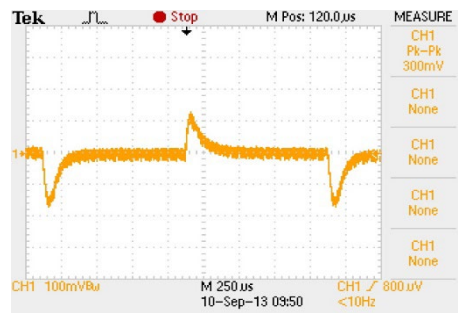
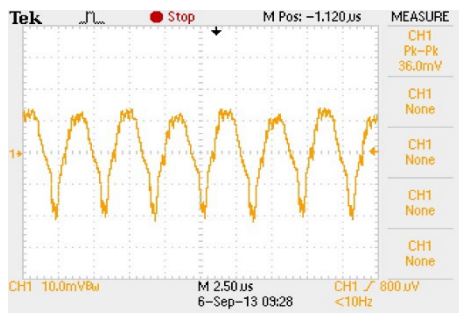
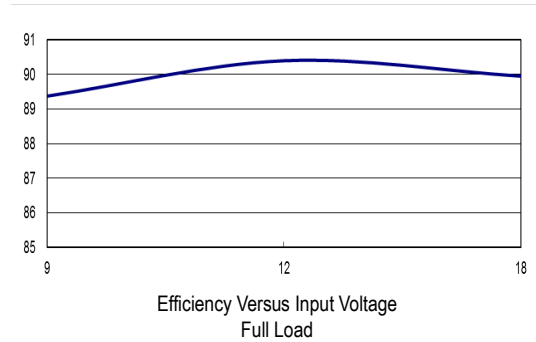
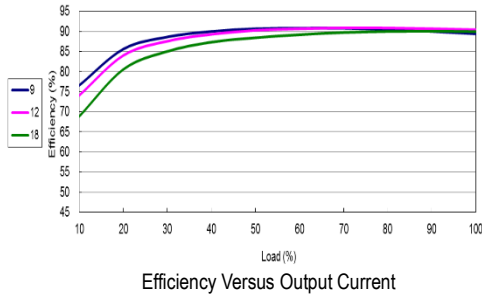

**Characteristic Curves**

All test conditions are at 25°C The figures are identical for MJW25-12D12

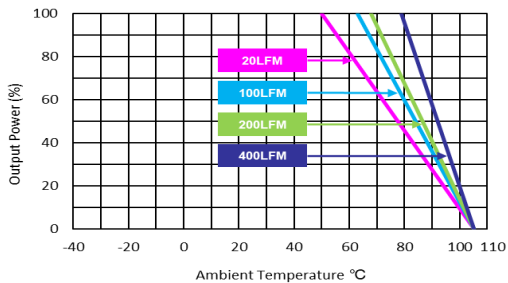
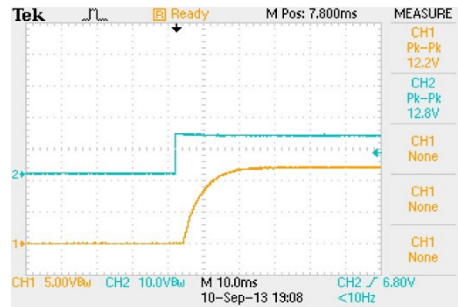
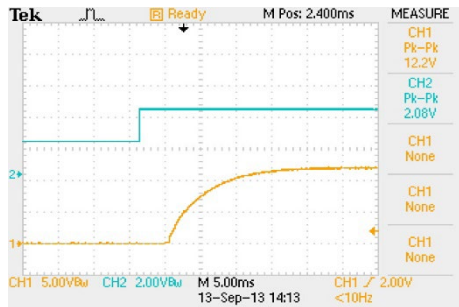
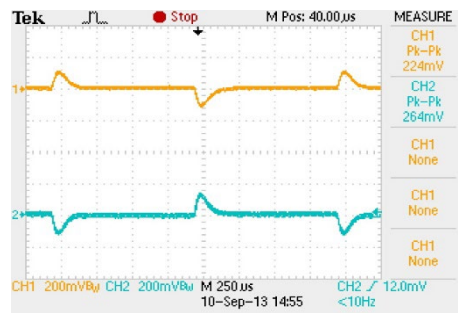
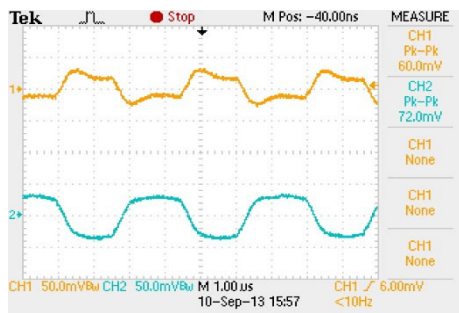
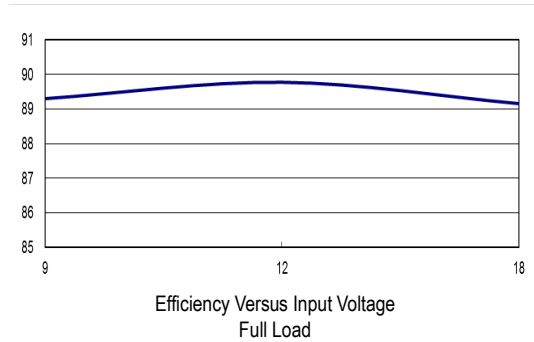
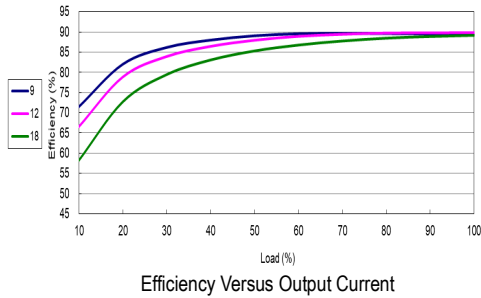

**Characteristic Curves**

All test conditions are at 25°C The figures are identical for MJW25-12D15

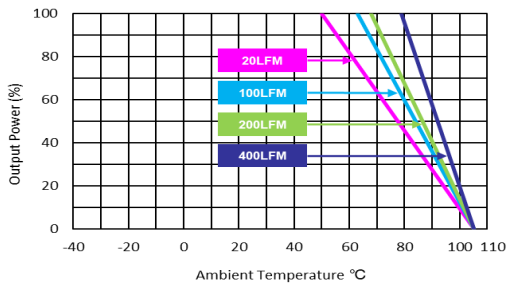
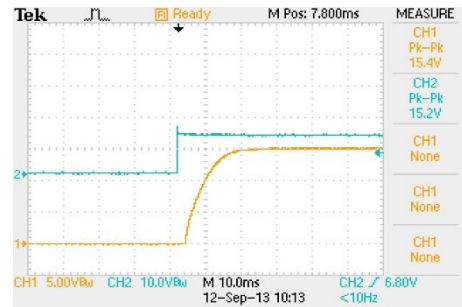
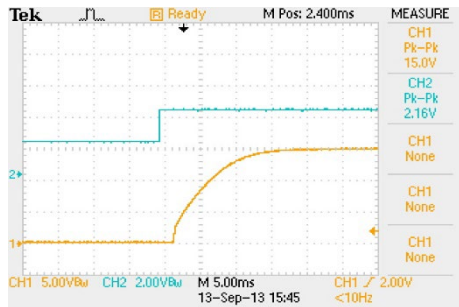
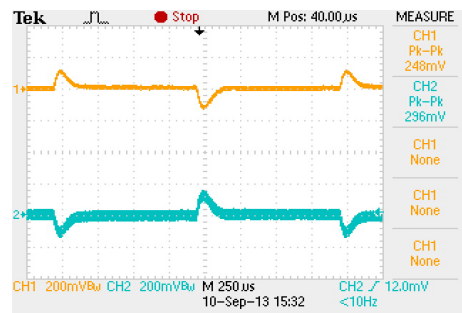
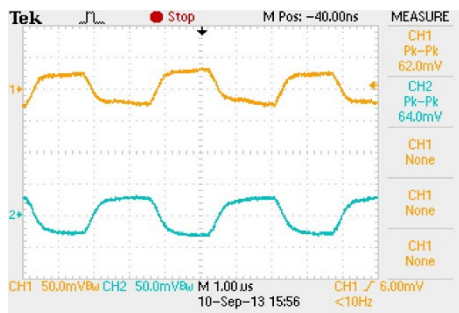
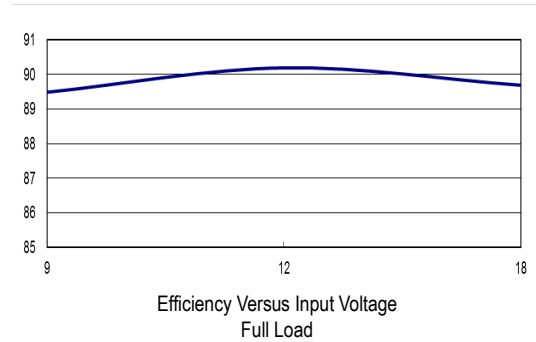
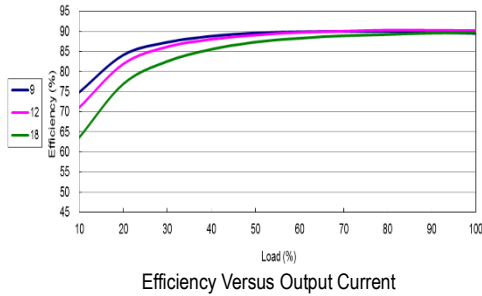

**Characteristic Curves**

All test conditions are at 25°C The figures are identical for MJW25-24S033

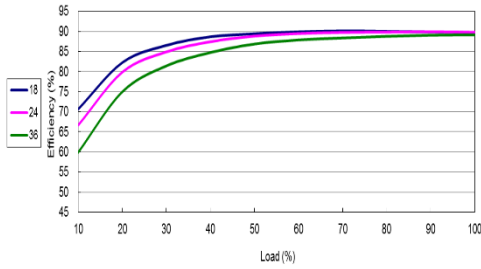

Efficiency Versus Output Current

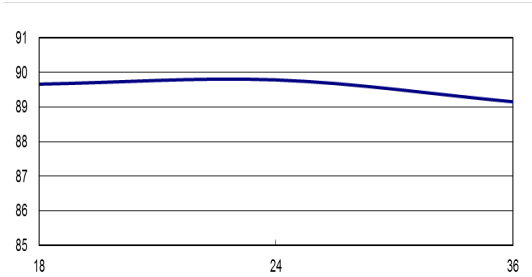

Efficiency Versus Input Voltage Full Load

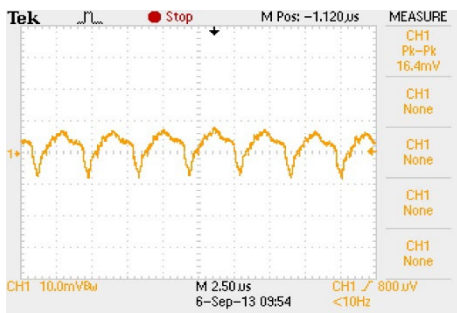

Typical Output Ripple and Noise.  
 $V_{in}=V_{in\ nom}$ ; Full Load



Transient Response to Dynamic Load Change  
from 100% to 75% of Full Load ;  $V_{in}=V_{in\ nom}$

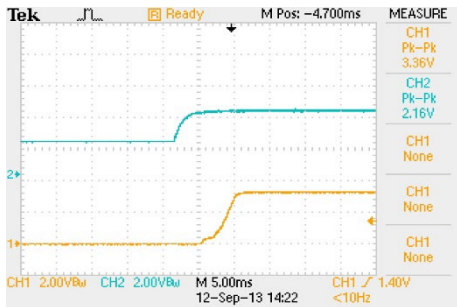

ON/OFF Voltage Start-Up and Output Rise Characteristic  
 $V_{in}=V_{in\ nom}$ ; Full Load

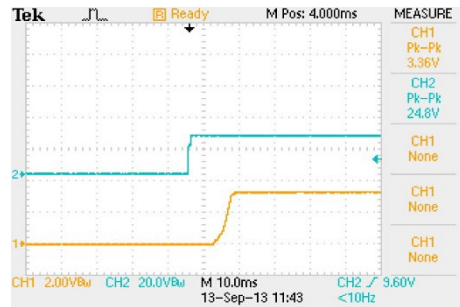

Typical Input Start-Up and Output Rise Characteristic  
 $V_{in}=V_{in\ nom}$ ; Full Load

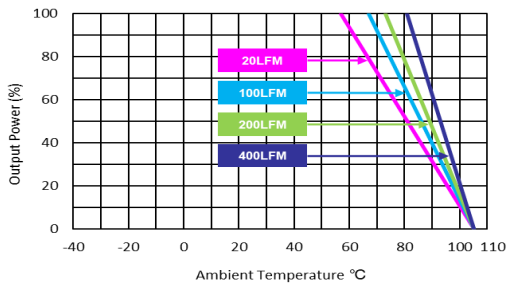

Derating Output Power Versus Ambient Temperature  
 $V_{in}=V_{in\ nom}$



**Characteristic Curves**

All test conditions are at 25°C The figures are identical for MJW25-24S05

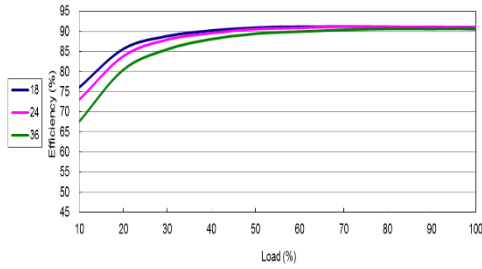

Efficiency Versus Output Current

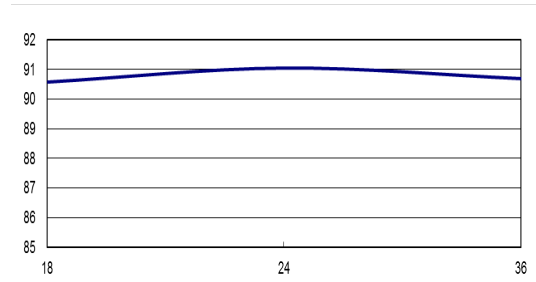

Efficiency Versus Input Voltage Full Load

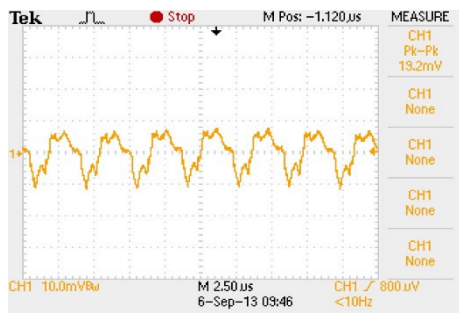

Typical Output Ripple and Noise.  
 $V_{in}=V_{in\ nom}$ ; Full Load

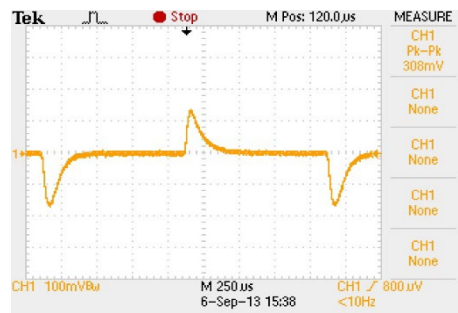

Transient Response to Dynamic Load Change  
from 100% to 75% of Full Load ;  $V_{in}=V_{in\ nom}$

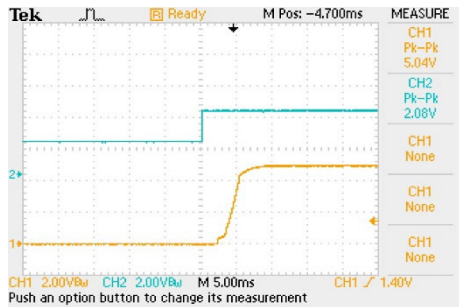

ON/OFF Voltage Start-Up and Output Rise Characteristic  
 $V_{in}=V_{in\ nom}$ ; Full Load

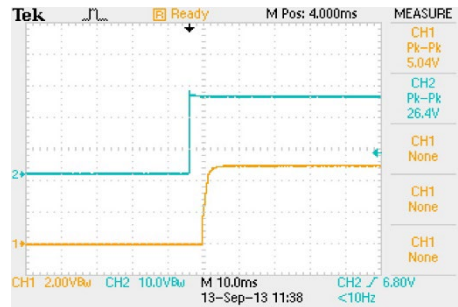

Typical Input Start-Up and Output Rise Characteristic  
 $V_{in}=V_{in\ nom}$ ; Full Load

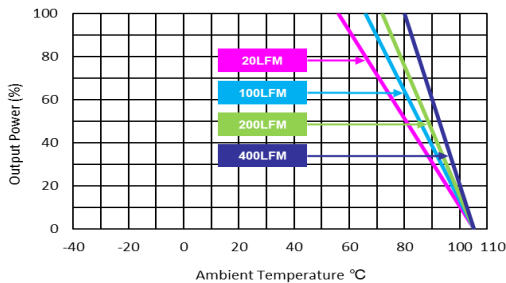

Derating Output Power Versus Ambient Temperature  
 $V_{in}=V_{in\ nom}$

**Characteristic Curves**

All test conditions are at 25°C The figures are identical for MJW25-24S12

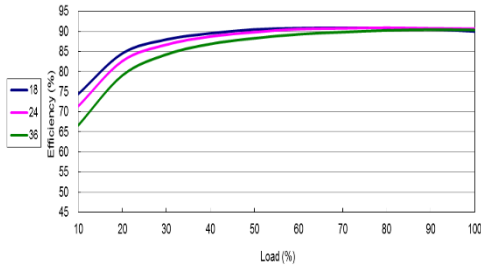

Efficiency Versus Output Current

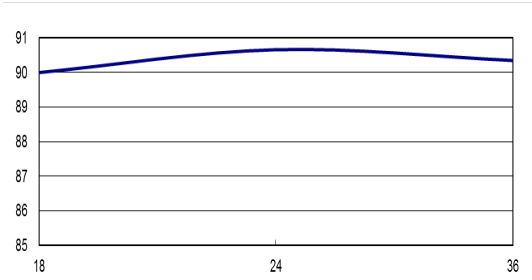

Efficiency Versus Input Voltage Full Load

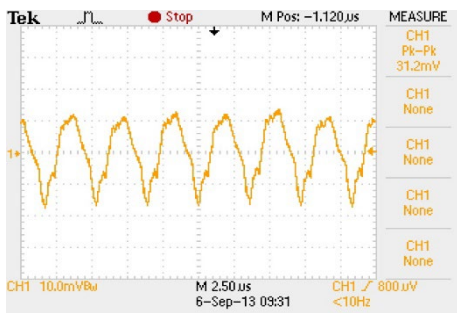

Typical Output Ripple and Noise.  
 $V_{in}=V_{in\ nom}$ ; Full Load

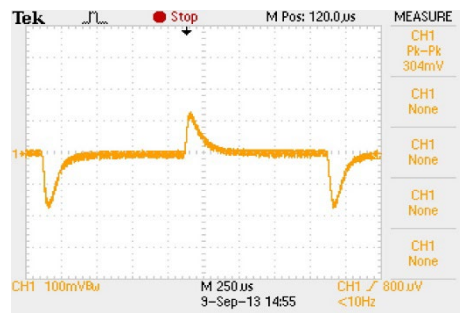

Transient Response to Dynamic Load Change  
from 100% to 75% of Full Load ;  $V_{in}=V_{in\ nom}$

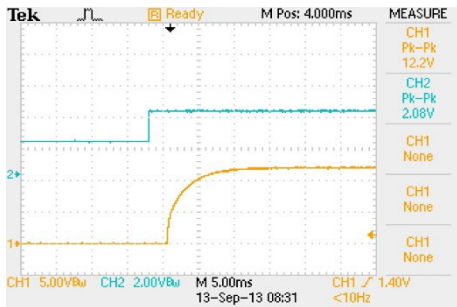

ON/OFF Voltage Start-Up and Output Rise Characteristic  
 $V_{in}=V_{in\ nom}$ ; Full Load

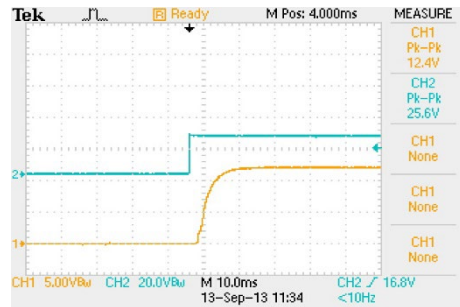

Typical Input Start-Up and Output Rise Characteristic  
 $V_{in}=V_{in\ nom}$ ; Full Load

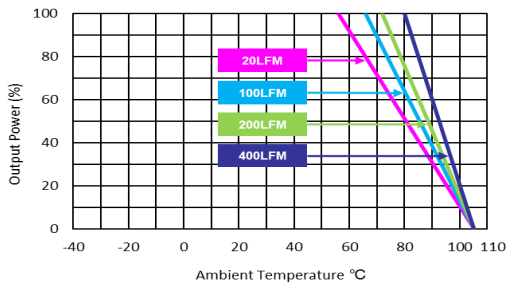

Derating Output Power Versus Ambient Temperature  
 $V_{in}=V_{in\ nom}$



**Characteristic Curves**

All test conditions are at 25°C The figures are identical for MJW25-24S15

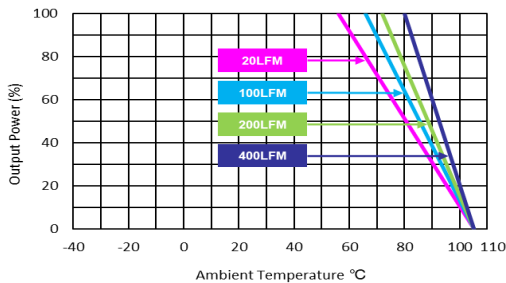
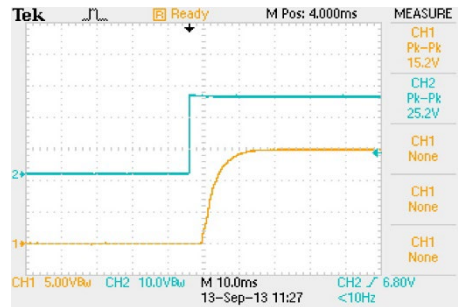
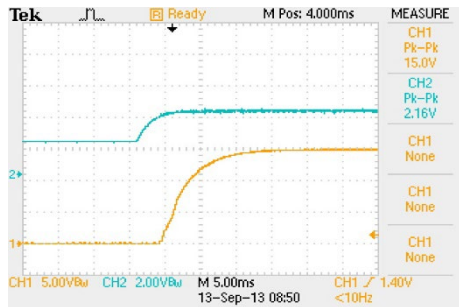
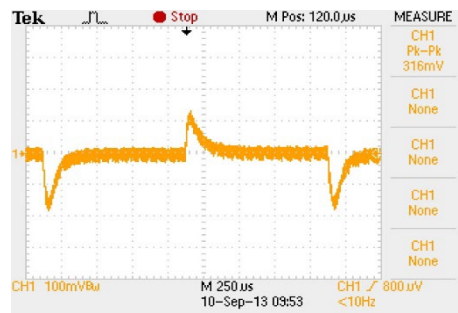
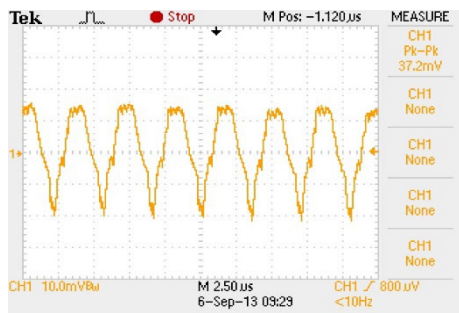
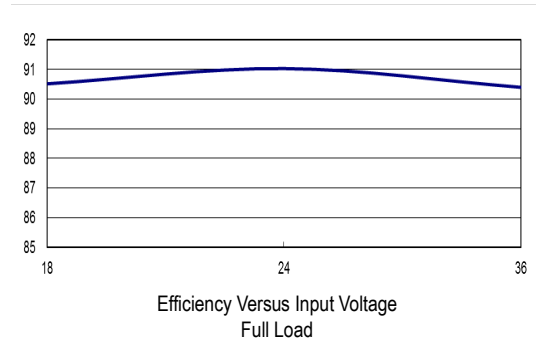
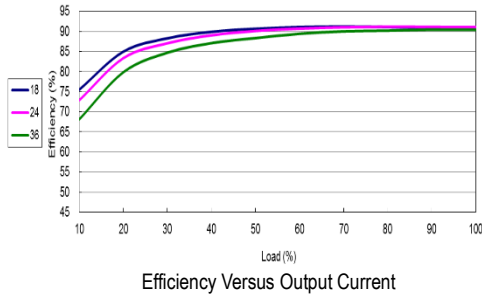

**Characteristic Curves**

All test conditions are at 25°C The figures are identical for MJW25-24D12

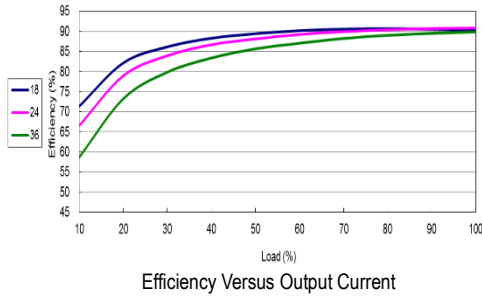

Efficiency Versus Output Current

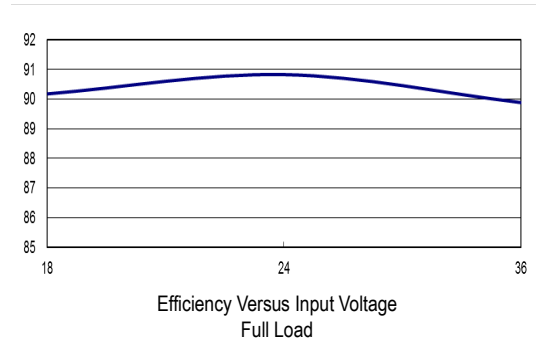

Efficiency Versus Input Voltage Full Load

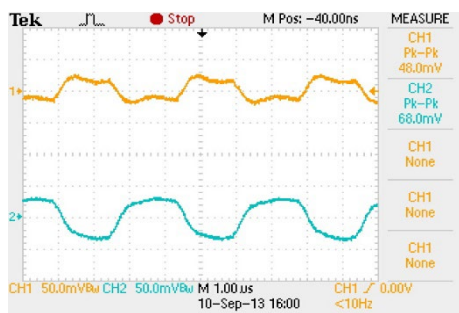

Typical Output Ripple and Noise.  
 $V_{in}=V_{in\ nom}$ ; Full Load

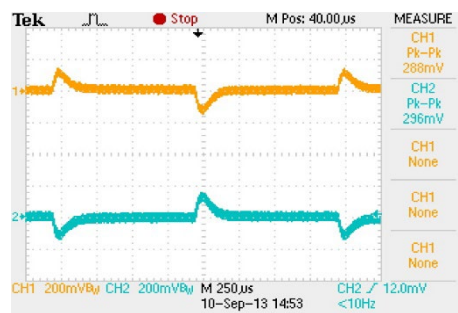

Transient Response to Dynamic Load Change  
from 100% to 75% of Full Load ;  $V_{in}=V_{in\ nom}$

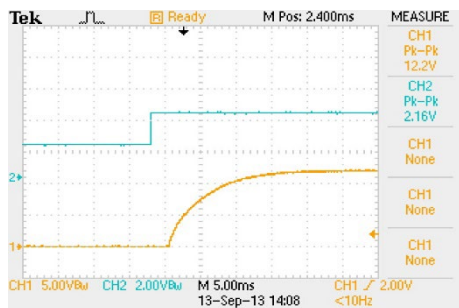

ON/OFF Voltage Start-Up and Output Rise Characteristic  
 $V_{in}=V_{in\ nom}$ ; Full Load

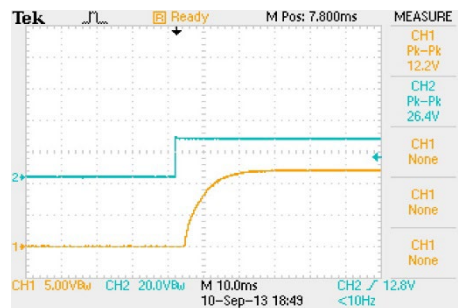

Typical Input Start-Up and Output Rise Characteristic  
 $V_{in}=V_{in\ nom}$ ; Full Load

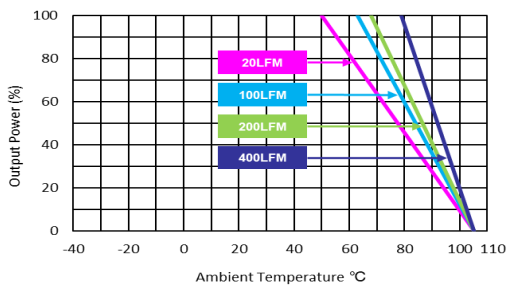

Derating Output Power Versus Ambient Temperature  
 $V_{in}=V_{in\ nom}$

**Characteristic Curves**

All test conditions are at 25°C The figures are identical for MJW25-24D15

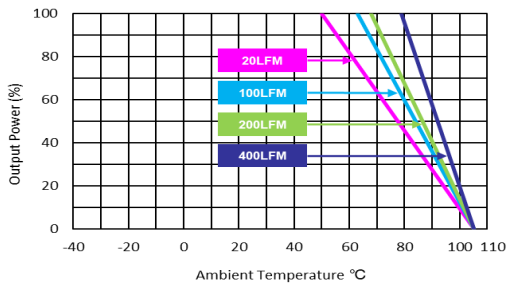
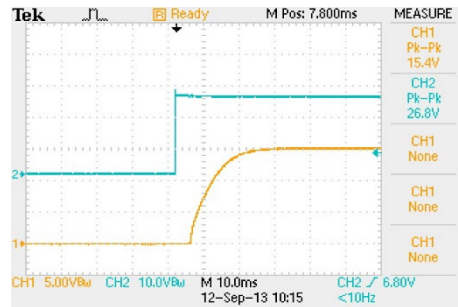
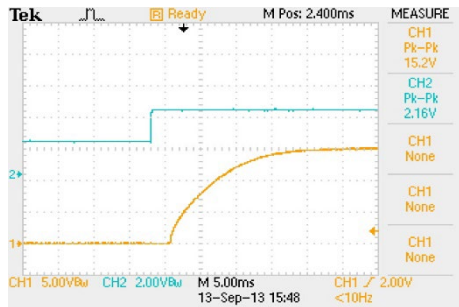
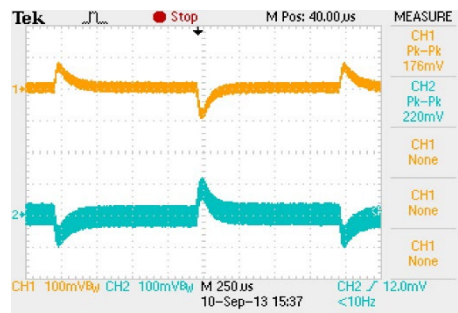
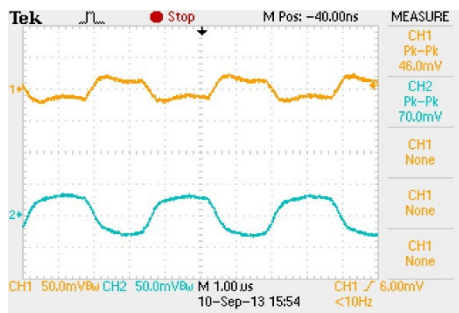
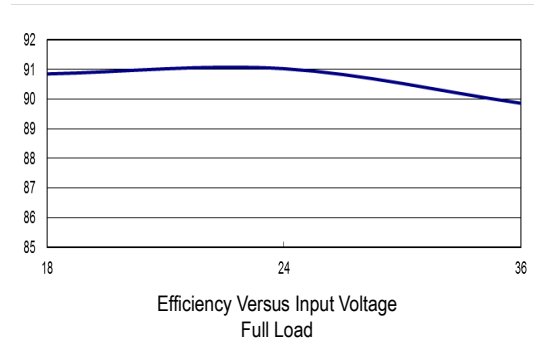
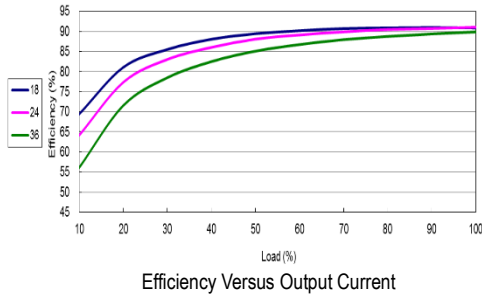

**Characteristic Curves**

All test conditions are at 25°C The figures are identical for MJW25-48S033

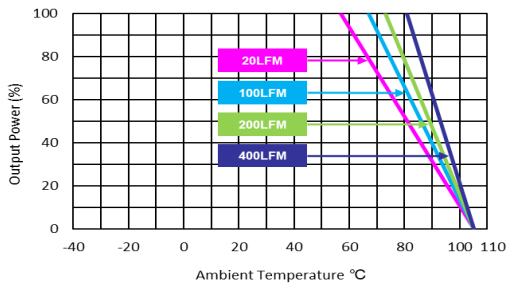
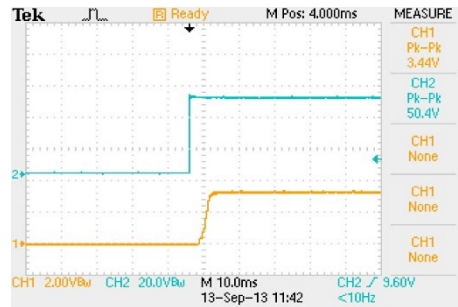
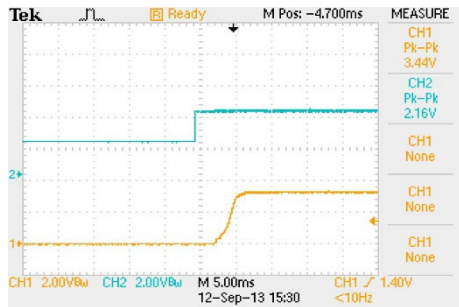
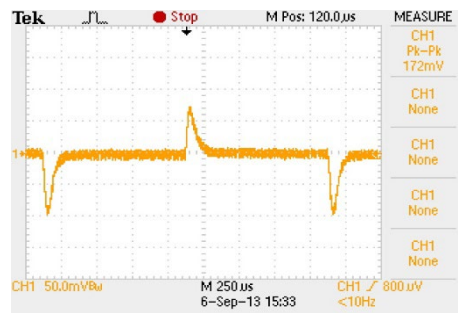
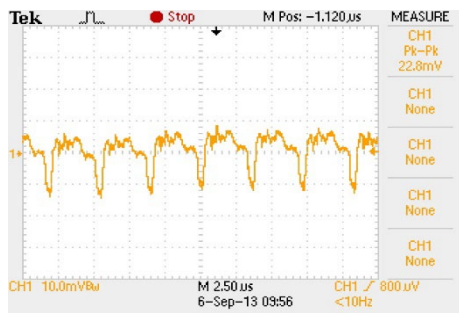
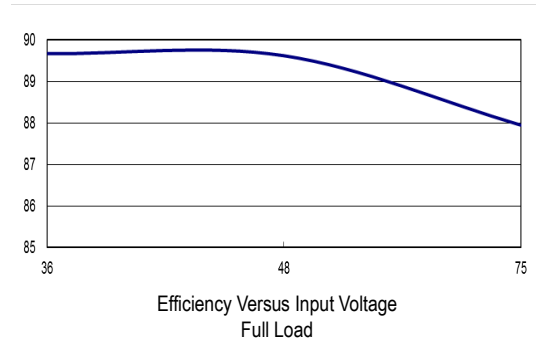
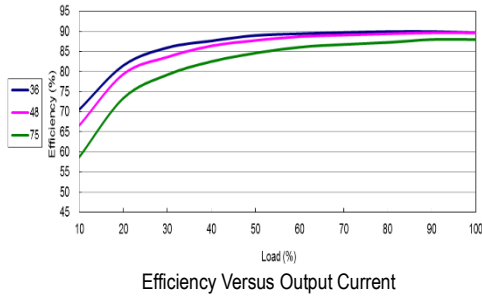



**Characteristic Curves**

All test conditions are at 25°C The figures are identical for MJW25-48S05

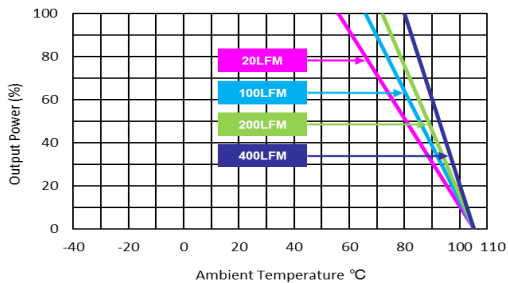
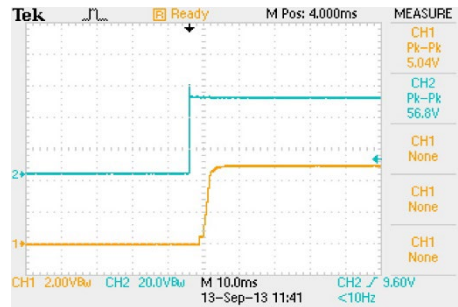
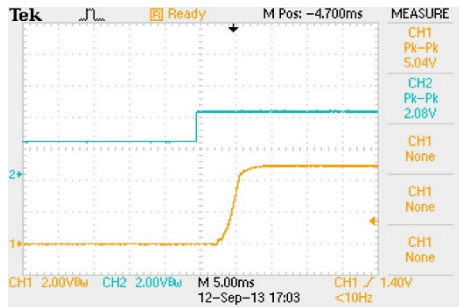
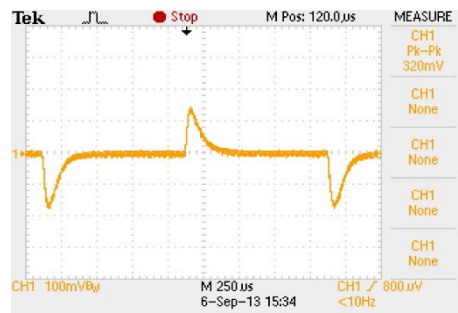
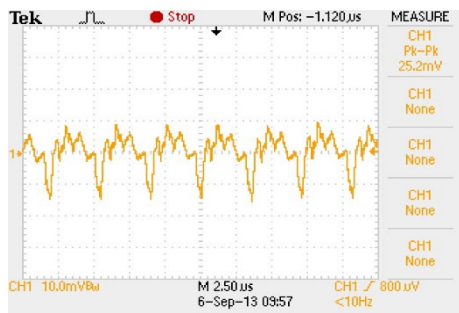
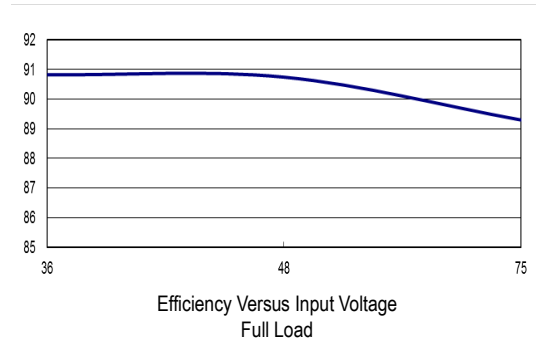
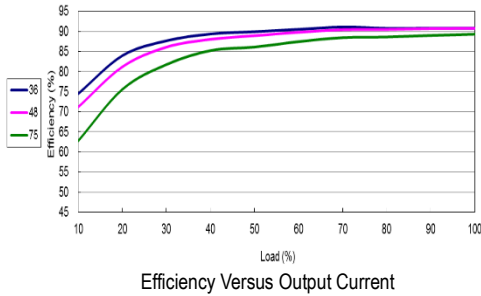

**Characteristic Curves**

All test conditions are at 25°C The figures are identical for MJW25-48S12

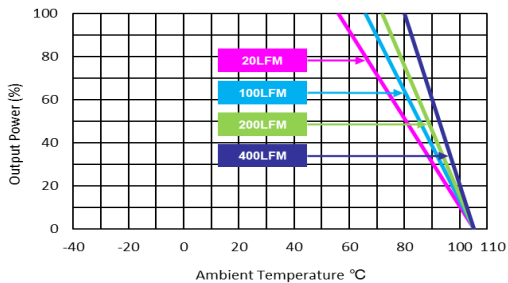
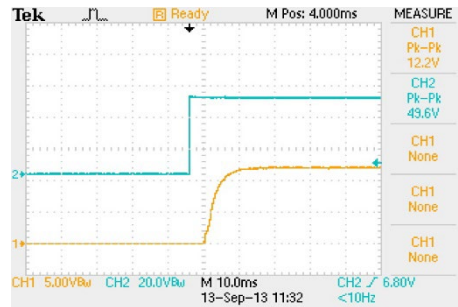
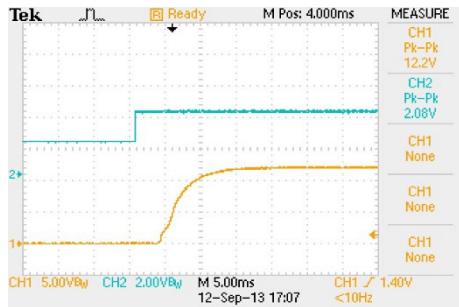
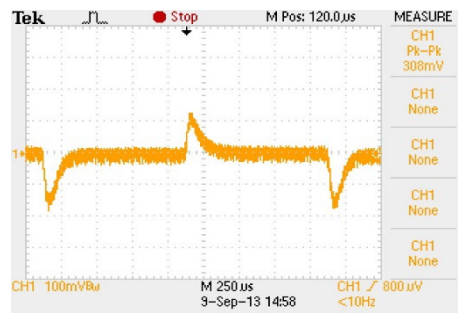
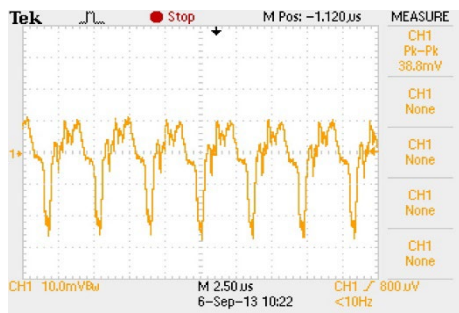
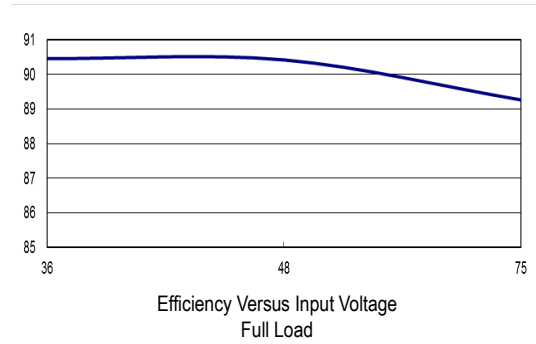
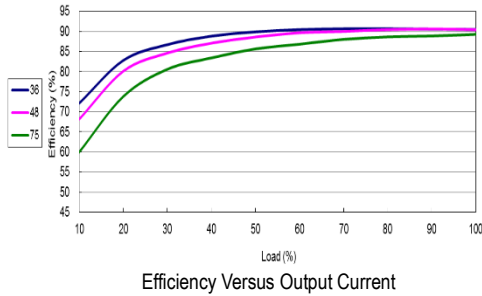



**Characteristic Curves**

All test conditions are at 25°C The figures are identical for MJW25-48S15

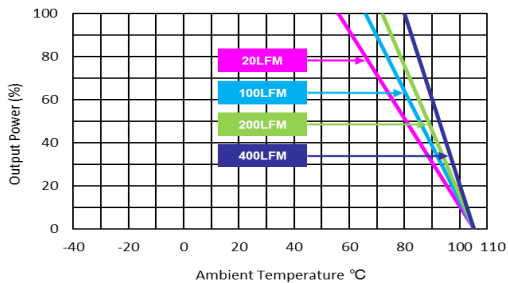
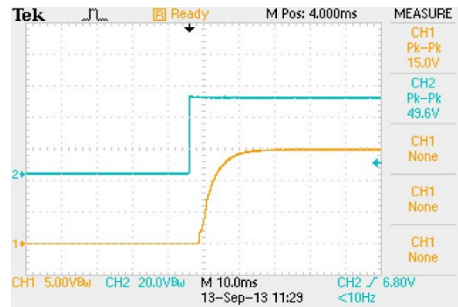
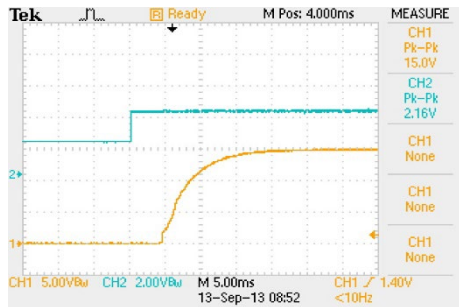
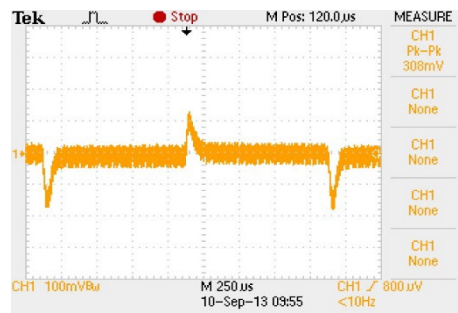
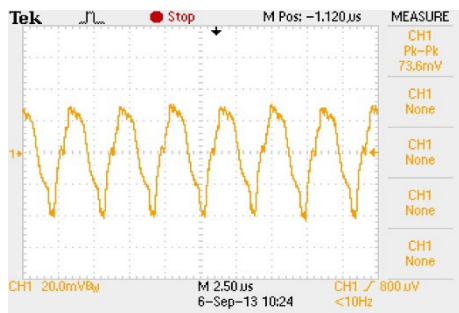
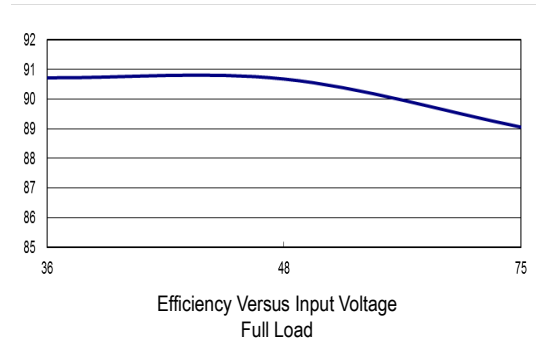
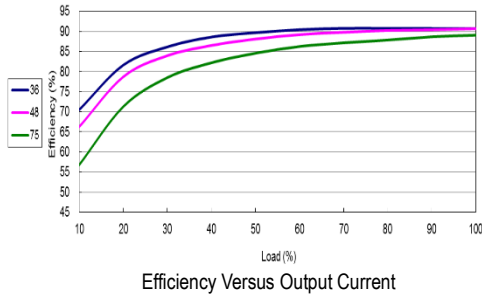

**Characteristic Curves**

All test conditions are at 25°C The figures are identical for MJW25-48D12

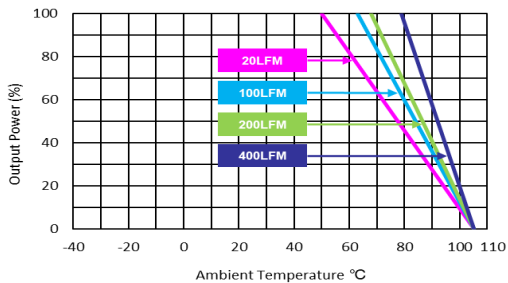
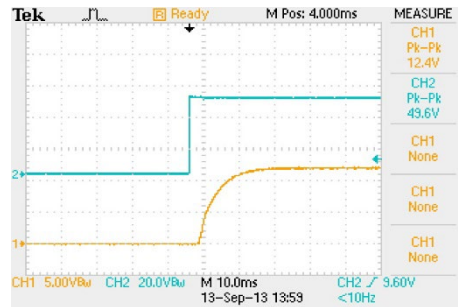
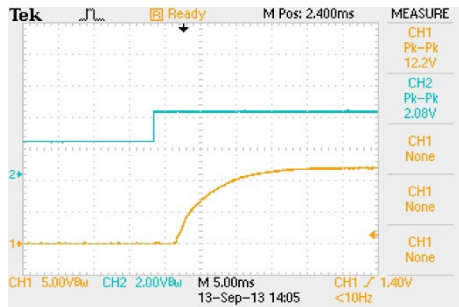
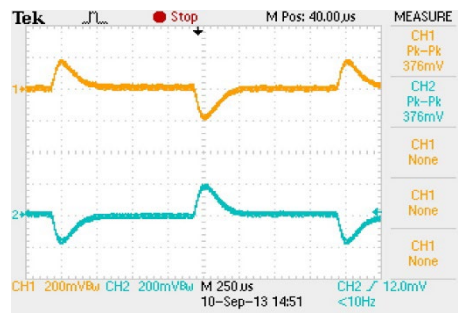
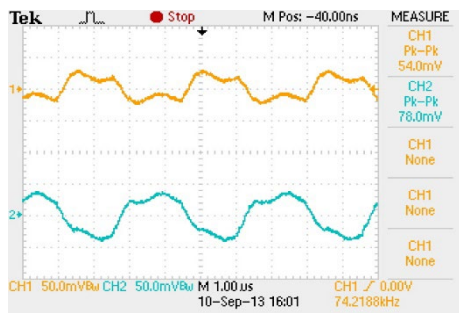
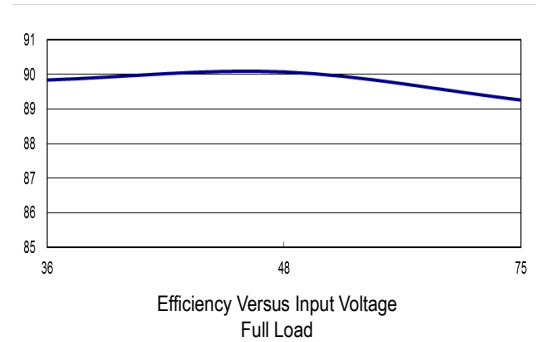
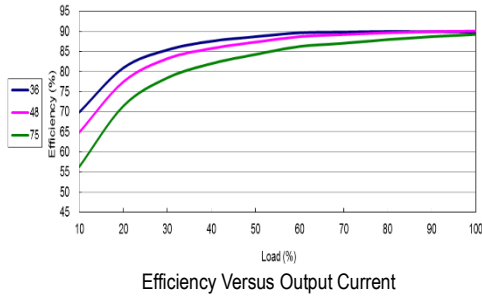

**Characteristic Curves**

All test conditions are at 25°C The figures are identical for MJW25-48D15

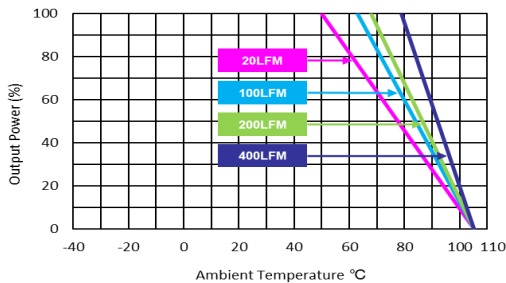
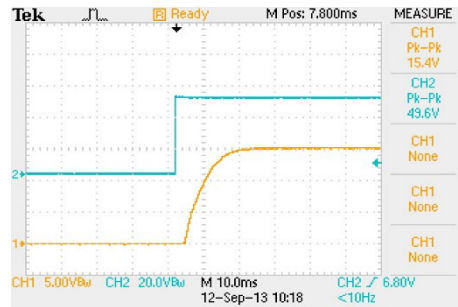
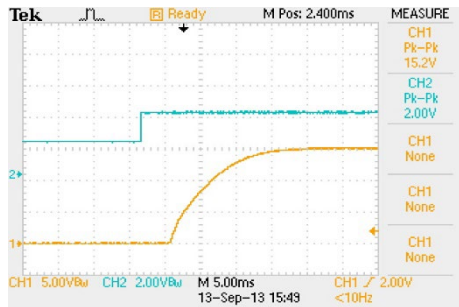
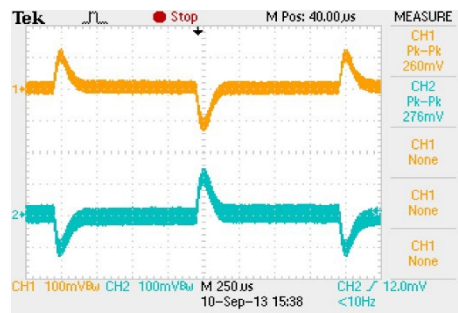
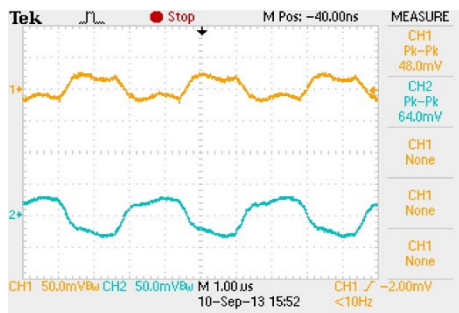
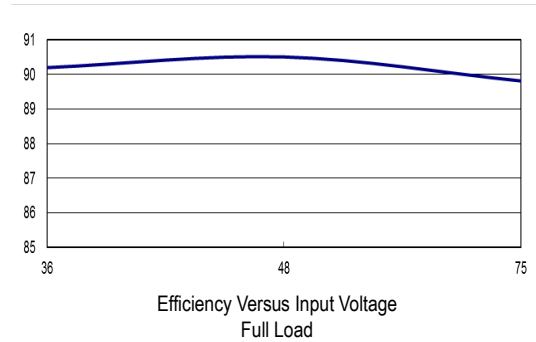
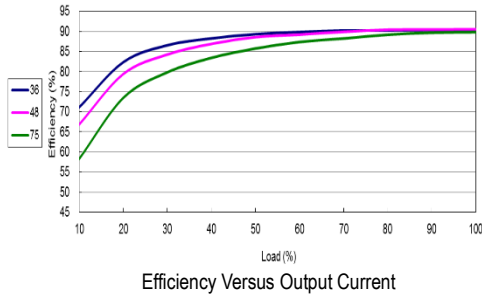

### Package Specifications

#### Mechanical Dimensions

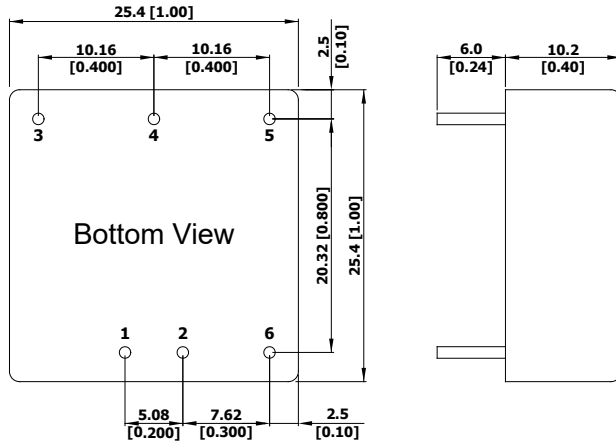

#### Pin Connections

Pin	Single Output	Dual Output	Diameter mm (inches)
1	+Vin	+Vin	Ø 1.0 [0.04]
2	-Vin	-Vin	Ø 1.0 [0.04]
3	+Vout	+Vout	Ø 1.0 [0.04]
4	Trim	Common	Ø 1.0 [0.04]
5	-Vout	-Vout	Ø 1.0 [0.04]
6	Remote On/Off	Remote On/Off	Ø 1.0 [0.04]

- ▶ All dimensions in mm (inches)
- ▶ Tolerance: X.X±0.5 (X.XX±0.02)  
X.XX±0.25 (X.XXX±0.01)
- ▶ Pin diameter tolerance: X.X±0.05 (X.XX±0.002)

### Physical Characteristics

Case Size	: 25.4x25.4x10.2mm (1.0x1.0x0.4 inches)
Case Material	: Metal With Non-Conductive Baseplate
Base Material	: FR4 PCB (flammability to UL 94V-0 rated)
Pin Material	: Copper Alloy
Weight	: 16.5g

### Heatsink (Option -HS)

#### Mechanical Dimensions

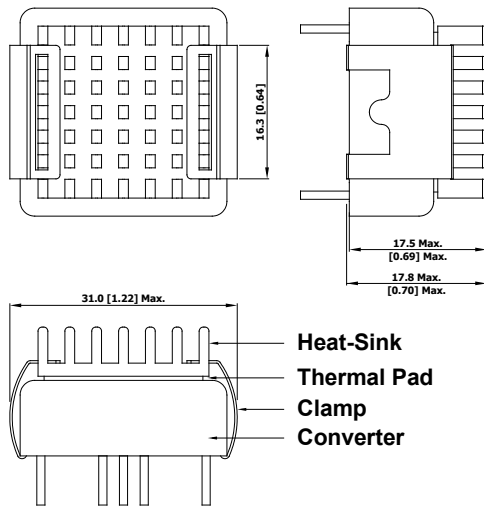

Heatsink Material: Aluminum  
 Finish: Anodic treatment (black)  
 Weight: 2g

- ▶ The advantages of adding a heatsink are:
  1. To improve heat dissipation and increase the stability and reliability of the DC-DC converters at high operating temperatures.
  2. To increase Operating temperature of the DC-DC converter, please refer to Derating Curve.

**Recommended Pad Layout for Single & Dual Output Converter**

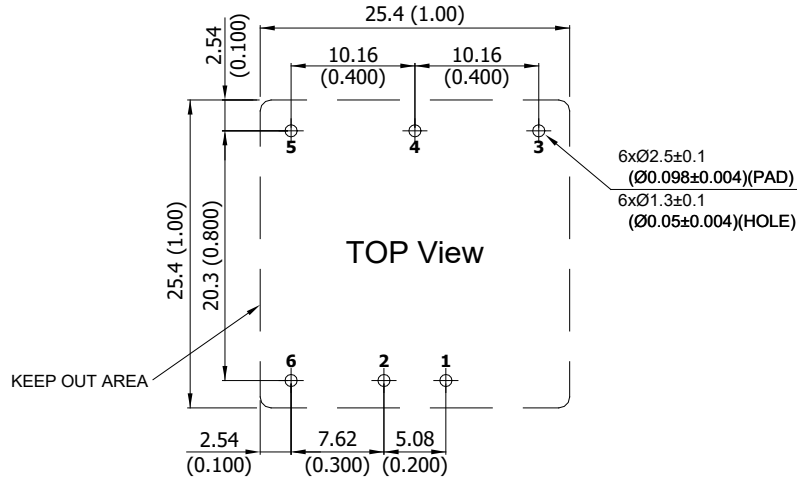

**External Output Trimming**

Output can be externally trimmed by using the method shown below

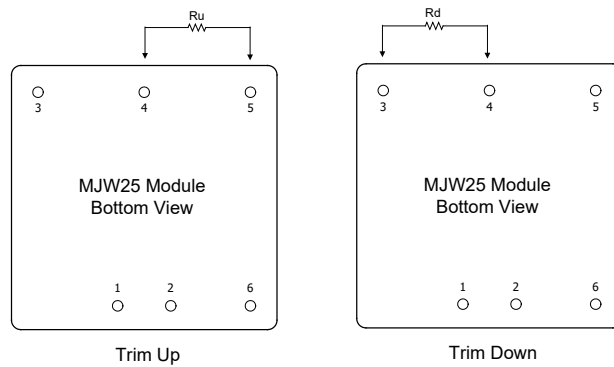

Trim Range (%)	MJW25-XXS033		MJW25-XXS05		MJW25-XXS12		MJW25-XXS15	
	Trim down (kΩ)	Trim up (kΩ)	Trim down (kΩ)	Trim up (kΩ)	Trim down (kΩ)	Trim up (kΩ)	Trim down (kΩ)	Trim up (kΩ)
1	72.61	60.84	138.88	106.87	413.55	351.00	530.73	422.77
2	32.55	27.40	62.41	47.76	184.55	157.50	238.61	189.89
3	19.20	16.25	36.92	28.06	108.22	93.00	141.24	112.26
4	12.52	10.68	24.18	18.21	70.05	60.75	92.56	73.44
5	8.51	7.34	16.53	12.30	47.15	41.40	63.35	50.15
6	5.84	5.11	11.44	8.36	31.88	28.50	43.87	34.63
7	3.94	3.51	7.79	5.55	20.98	19.29	29.96	23.54
8	2.51	2.32	5.06	3.44	12.80	12.37	19.53	15.22
9	1.39	1.39	2.94	1.79	6.44	7.00	11.41	8.75
10	0.50	0.65	1.24	0.48	1.35	2.70	4.92	3.58



## Test Setup

### Input Reflected-Ripple Current Test Setup

Input reflected-ripple current is measured with an inductor  $L_{in}$  (4.7 $\mu$ H) and  $C_{in}$  (220 $\mu$ F, ESR < 1.0 $\Omega$  at 100 kHz) to simulate source impedance. Capacitor  $C_{in}$ , offsets possible battery impedance. Current ripple is measured at the input terminals of the module, measurement bandwidth is 0-500 kHz.

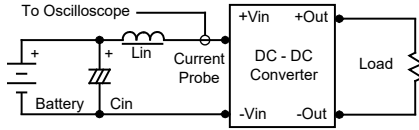

### Peak-to-Peak Output Noise Measurement Test

Use a 1 $\mu$ F ceramic capacitor and a 10 $\mu$ F tantalum capacitor. Scope measurement should be made by using a BNC socket, measurement bandwidth is 0-20 MHz. Position the load between 50 mm and 75 mm from the DC-DC Converter.



## Technical Notes

### Remote On/Off

Positive logic remote on/off turns the module on during a logic high voltage on the remote on/off pin, and off during a logic low. To turn the power module on and off, the user must supply a switch to control the voltage between the on/off terminal and the -Vin terminal. The switch can be an open collector or equivalent. A logic low is 0V to 1.2V. A logic high is 3.5V to 12V. The maximum sink current at the on/off terminal (Pin 6) during a logic low is -500 $\mu$ A. The maximum allowable leakage current of a switch connected to the on/off terminal (Pin 6) at logic high (3.5V to 12V) is 10mA.

### Overload Protection

To provide hiccup mode protection in a fault (output overload) condition, the unit is equipped with internal current limiting circuitry and can endure overload for an unlimited duration.

### Overvoltage Protection

The output overvoltage clamp consists of control circuitry, which is independent of the primary regulation loop, that monitors the voltage on the output terminals. The control loop of the clamp has a higher voltage set point than the primary loop. This provides a redundant voltage control that reduces the risk of output overvoltage. The OVP level can be found in the output data.

### Input Source Impedance

The power module should be connected to a low ac-impedance input source. Highly inductive source impedances can affect the stability of the power module. In applications where power is supplied over long lines and output loading is high, it may be necessary to use a capacitor at the input to ensure startup. Capacitor mounted close to the power module helps ensure stability of the unit, it is recommended to use a good quality low Equivalent Series Resistance (ESR < 1.0 $\Omega$  at 100 kHz) capacitor of a 10 $\mu$ F for the 24V and 48V devices.

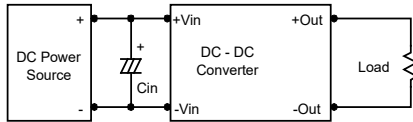

### Output Ripple Reduction

A good quality low ESR capacitor placed as close as practicable across the load will give the best ripple and noise performance. To reduce output ripple, it is recommended to use 4.7 $\mu$ F capacitors at the output.

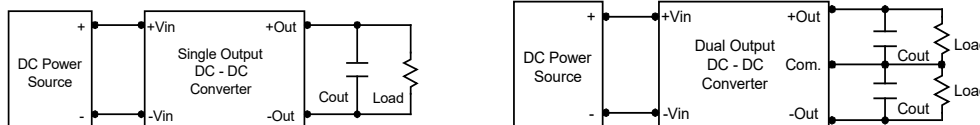

### Maximum Capacitive Load

The MJW25 series has limitation of maximum connected capacitance at the output. The power module may be operated in current limiting mode during start-up, affecting the ramp-up and the startup time. The maximum capacitance can be found in the data sheet.

### Thermal Considerations

Many conditions affect the thermal performance of the power module, such as orientation, airflow over the module and board spacing. To avoid exceeding the maximum temperature rating of the components inside the power module, the case temperature must be kept below 105 $^{\circ}$ C. The derating curves are determined from measurements obtained in a test setup.

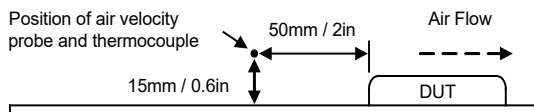



**Remote On/Off Implementation**

The positive logic remote ON/OFF control circuit is included. Turns the module ON during logic High on the ON/Off pin and turns OFF during logic Low. The ON/OFF input signal (Von/off) that referenced to GND. If not using the remote on/off feature, please open circuit between on/off pin and -Vin pin to turn the module on.

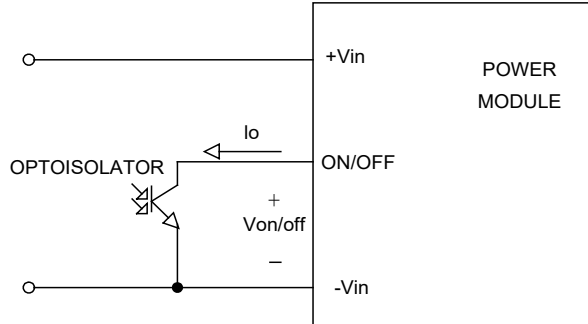

Isolated-Closure Remote ON/OFF

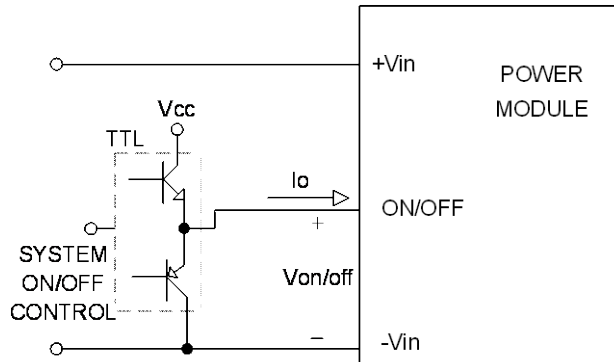

Level Control Using TTL Output

**Packaging Information for Tube**

Tube

Nail

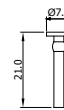
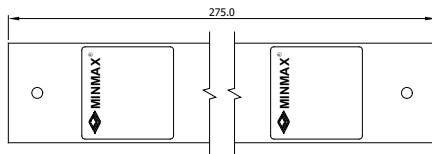
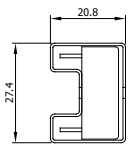

Unit: mm  
10 PCS per TUBE (without Heatsink)

Tube

Plug

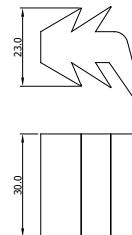
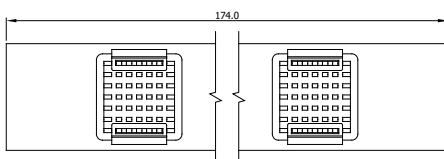
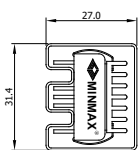

Unit: mm  
5 PCS per TUBE (with Heatsink)

**Wave Soldering Considerations**

Lead free wave solder profile

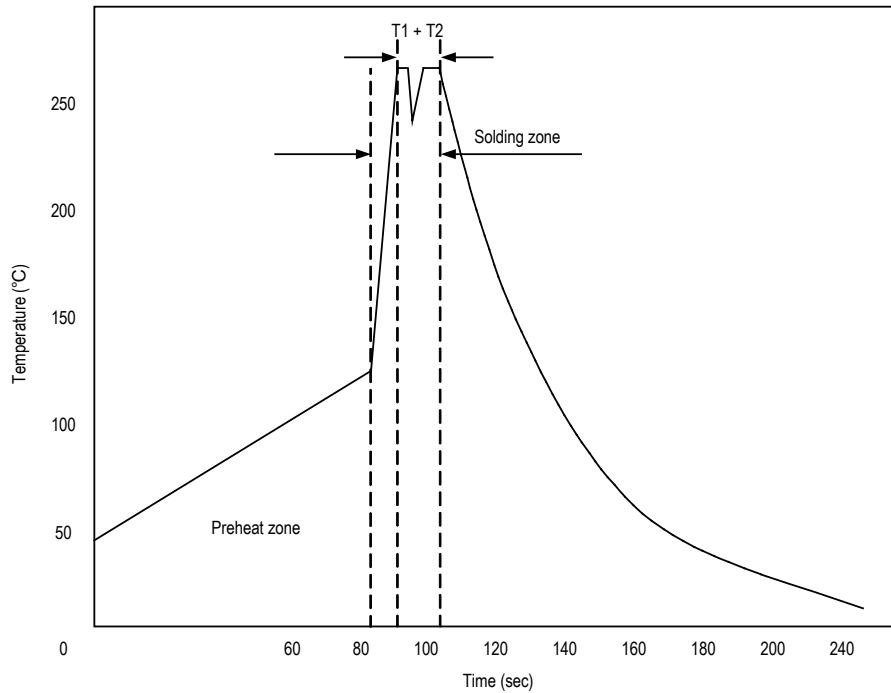

Zone	Reference Parameter
Preheat	Rise temp. speed : 3°C/sec max.
zone	Preheat temp. : 100~130°C
Actual	Peak temp. : 250~260°C
heating	Peak time(T1+T2) : 4~6 sec

**Hand Welding Parameter**

Reference Solder: Sn-Ag-Cu : Sn-Cu : Sn-Ag

Hand Welding: Soldering iron : Power 60W

Welding Time: 2~4 sec

Temp.: 380~400°C

Part Number Structure							
<b>M</b>	<b>J</b>	<b>W</b>	<b>25</b>	-	<b>12</b>	<b>S</b>	<b>033</b>
Package Type 1" X 1"	Wide 2:1 Input Voltage Range		Output Power 25 Watt		Input Voltage Range	Output Quantity S: Single D: Dual	Output Voltage
					12: 9 ~ 18 VDC 24: 18 ~ 36 VDC 48: 36 ~ 75 VDC		033: 3.3 VDC 05: 5 VDC 12: 12 VDC 15: 15 VDC

MTBF and Reliability		
The MTBF of MJW25 series of DC-DC converters has been calculated using MIL-HDBK 217F NOTICE2, Operating Temperature 25°C, Ground Benign.		
Model	MTBF	Unit
MJW25-12S033	361,602	Hours
MJW25-12S05	313,256	
MJW25-12S12	344,818	
MJW25-12S15	337,443	
MJW25-12D12	375,529	
MJW25-12D15	340,096	
MJW25-24S033	412,089	
MJW25-24S05	367,486	
MJW25-24S12	403,593	
MJW25-24S15	395,171	
MJW25-24D12	377,995	
MJW25-24D15	342,117	
MJW25-48S033	402,022	
MJW25-48S05	359,079	
MJW25-48S12	393,475	
MJW25-48S15	385,466	
MJW25-48D12	377,995	
MJW25-48D15	342,117	