



MINMAX[®]

MKW40 Series

Electric Characteristic Note

MKW40 Series EC Note

DC-DC CONVERTER 40W, Highest Power Density

Features

- ▶ Smallest Encapsulated 40W Converter
- ▶ Compact Size of 2" X 1" Package
- ▶ Wide 2:1 Input Voltage Range
- ▶ Fully Regulated Output Voltage
- ▶ Excellent Efficiency up to 92%
- ▶ I/O Isolation 1500 VDC
- ▶ Operating Ambient Temp. Range -40°C to +80°C
- ▶ No Min. Load Requirement
- ▶ Overload/Voltage/Temp. and Short Circuit Protection
- ▶ Remote On/Off Control, Output Voltage Trim
- ▶ Shielded Metal Case with Insulated Baseplate
- ▶ UL/cUL/IEC/EN 62368-1(60950-1) Safety Approval

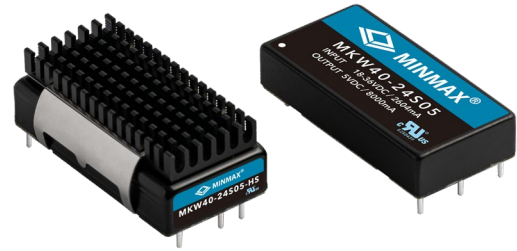

Applications

- ▶ Distributed power architectures
- ▶ Workstations
- ▶ Computer equipment
- ▶ Communications equipment

Product Overview

The MINMAX MKW40 series is a generation of high performance DC-DC converter modules. The product offers fully 40W in an encapsulated, shielded metal package with dimensions of just 2.0"x1.0"x0.4". All models provide wide 2:1 input voltage range and precisely regulated output voltages. Advanced circuit topology provides a very high efficiency up to 92% which allows an operating temperature range of -40°C to +80°C. Further features include remote On/Off, trimmable output voltage, under-voltage shutdown as well as overload and over-temperature protection. Typical applications for these converters are battery operated equipment, instrumentation, distributed power architectures in communication and industrial electronics and many other space critical applications.

Table of contents

Model Selection Guide	P2	External Output Trimming.....	P27
Input Specifications.....	P2	Test Setup.....	P28
Remote On/Off Control	P2	Technical Notes	P28
Output Specifications.....	P3	Remote ON/OFF Implementation.....	P29
General Specifications.....	P3	Packaging Information.....	P29
EMC Specifications.....	P3	Wave Soldering Considerations	P30
Environmental Specifications	P4	Hand Welding Parameter	P30
Characteristic Curves	P5	Part Number Structure	P31
Package Specifications	P26	MTBF and Reliability	P31
Recommended Pad Layout for Single & Dual Output Converter.....	P27		

Model Selection Guide

Model Number	Input Voltage (Range) VDC	Output Voltage VDC	Output Current		Input Current		Reflected Ripple Current mA (typ.)	Over Voltage Protection VDC	Max. capacitive Load μF	Efficiency (typ.)
			Max.	Min.	@Max. Load	@No Load				@Max. Load
			mA	mA	mA(typ.)	mA(typ.)				%
MKW40-12S033	12 (9 ~ 18)	3.3	8000	0	2470	120	50	3.9	21000	89
MKW40-12S05		5	8000	0	3750	160		6.2	13600	89
MKW40-12S12		12	3330	0	3750	160		15	2400	89
MKW40-12S15		15	2670	0	3700	150		18	1500	90
MKW40-12S24		24	1670	0	3670	160		30	600	91
MKW40-12D12		±12	±1670	±145	3790	70		±15	1200#	88
MKW40-12D15		±15	±1330	±110	3790	60		±18	750#	88
MKW40-24S033	24 (18 ~ 36)	3.3	8000	0	1220	75	30	3.9	21000	90
MKW40-24S05		5	8000	0	1830	80		6.2	13600	91
MKW40-24S12		12	3330	0	1830	85		15	2400	91
MKW40-24S15		15	2670	0	1830	75		18	1500	91
MKW40-24S24		24	1670	0	1835	85		30	600	91
MKW40-24D12		±12	±1670	±145	1870	50		±15	1200#	89
MKW40-24D15		±15	±1330	±110	1870	45		±18	750#	89
MKW40-48S033	48 (36 ~ 75)	3.3	8000	0	610	40	20	3.9	21000	90
MKW40-48S05		5	8000	0	920	50		6.2	13600	91
MKW40-48S12		12	3330	0	910	50		15	2400	92
MKW40-48S15		15	2670	0	910	50		18	1500	92
MKW40-48S24		24	1670	0	918	50		30	600	91
MKW40-48D12		±12	±1670	±145	940	65		±15	1200#	89
MKW40-48D15		±15	±1330	±110	940	65		±18	750#	89

For each output

Input Specifications

Parameter	Conditions / Model	Min.	Typ.	Max.	Unit
Input Surge Voltage (1 sec. max.)	12V Input Models	-0.7	---	25	VDC
	24V Input Models	-0.7	---	50	
	48V Input Models	-0.7	---	100	
Start-Up Threshold Voltage	12V Input Models	---	---	9	
	24V Input Models	---	---	18	
	48V Input Models	---	---	36	
Under Voltage Shutdown	12V Input Models	---	8.3	---	
	24V Input Models	---	16.5	---	
	48V Input Models	---	33	---	
Start Up Time	Power Up	---	---	30	ms
	Remote On/Off	Nominal Vin and Constant Resistive Load	---	---	30
Input Filter	All Models	Internal LC Type			

Remote On/Off Control

Parameter	Conditions	Min.	Typ.	Max.	Unit
Converter On	3.5V ~ 12V or Open Circuit				
Converter Off	0V ~ 1.2V or Short Circuit				
Control Input Current (on)	Vctrl = 5.0V	---	0.5	---	mA
Control Input Current (off)	Vctrl = 0V	---	-0.5	---	mA
Control Common	Referenced to Negative Input				
Standby Input Current	Nominal Vin	---	2.5	---	mA

Output Specifications						
Parameter	Conditions / Model		Min.	Typ.	Max.	Unit
Output Voltage Setting Accuracy			---	---	±1.0	%Vnom.
Output Voltage Balance	Dual Output, Balanced Loads		---	---	±2.0	%
Line Regulation	Vin=Min. to Max. @Full Load		---	---	±0.5	%
Load Regulation	Min. Load to Full Load	Single Output	---	---	±0.5	%
		Dual Output	---	---	±1.0	%
Load Cross Regulation (Dual Output)	Asymmetrical Load 25%/100% Full Load		---	---	±5.0	%
Minimum Load	No Minimum Load Requirement for Single Output Models, for dual Output Models see Table					
Ripple & Noise	0-20 MHz Bandwidth	3.3V & 5V Output Models	---	100	---	mV _{P-P}
		12V, 15V & 24V Models	---	150	---	mV _{P-P}
		Dual Output Models	---	150	---	mV _{P-P}
Transient Recovery Time	25% Load Step Change		---	250	---	μsec
Transient Response Deviation			---	±3	±5	%
Temperature Coefficient			---	---	±0.02	%/°C
Trim Up / Down Range (See Page 6)	% of Nominal Output Voltage	24Vo Models	---	---	+20 / -10	%
		Other Models	---	---	±10	
Over Current Protection	Current Limitation at 150% typ. of Iout max., Hiccup					
Short Circuit Protection	24Vo Models		Continuous, Automatic Recovery (Hiccup Mode 0.3Hz typ.)			
	Other Models		Continuous, Automatic Recovery (Hiccup Mode 1.5Hz typ.)			

General Specifications						
Parameter	Conditions / Model		Min.	Typ.	Max.	Unit
I/O Isolation Voltage	60 Seconds		1500	---	---	VDC
	1 Seconds		1800	---	---	VDC
I/O Isolation Resistance	500 VDC		1000	---	---	MΩ
I/O Isolation Capacitance	100kHz, 1V		---	---	1500	pF
Switching Frequency	24Vo Models		---	285	---	kHz
	Other Models		---	320	---	kHz
MTBF(calculated)	MIL-HDBK-217F@25°C, Ground Benign		328,000			Hours
Safety Approvals	UL/cUL 60950-1 recognition(CSA certificate), IEC/EN 60950-1(CB-report)					
	UL/cUL 62368-1 recognition(UL certificate), IEC/EN 62368-1(CB-report)					

EMC Specifications					
Parameter	Standards & Level			Performance	
EMI ₍₅₎	Conduction	EN 55032	With external components	Class A	
EMS ₍₅₎	EN 55024				
	ESD	EN61000-4-2 air ± 8kV , Contact ± 6kV			B
	Radiated immunity	EN61000-4-3 10V/m			A
	Fast transient	EN61000-4-4 ±2kV			A
	Surge	EN61000-4-5 ±1kV			B
	Conducted immunity	EN61000-4-6 10Vrms			A

Environmental Specifications					
Parameter	Conditions / Model	Min.	Max.		Unit
			without Heatsink	with Heatsink	
Operating Ambient Temperature Range Nominal Vin, Load 100% Inom. (for Power Derating see relative Derating Curves)	MKW40-XXS033	-40	66	73	°C
	MKW40-XXS05		46	57	
	MKW40-XXS12				
	MKW40-XXS15				
	MKW40-XXS24				
	MKW40-XXDXX		40	52	
Thermal Impedance	20LFM Convection without Heatsink	12.0	---		°C/W
	20LFM Convection with Heatsink	10.0	---		°C/W
	100LFM Convection without Heatsink	9.0	---		°C/W
	100LFM Convection with Heatsink	5.4	---		°C/W
	200LFM Convection without Heatsink	8.0	---		°C/W
	200LFM Convection with Heatsink	4.5	---		°C/W
	400LFM Convection without Heatsink	6.0	---		°C/W
	400LFM Convection with Heatsink	3.0	---		°C/W
Case Temperature		---	+105		°C
Thermal Protection	Shutdown Temperature		110°C typ.		
Storage Temperature Range		-50	+125		°C
Humidity (non condensing)		---	95		% rel. H
RFI	Six-Sided Shielded, Metal Case				
Lead Temperature (1.5mm from case for 10Sec.)		---	260		°C

Notes

- 1 Specifications typical at Ta=+25°C, resistive load, nominal input voltage and rated output current unless otherwise noted.
- 2 Transient recovery time is measured to within 1% error band for a step change in output load of 75% to 100%.
- 3 Ripple & Noise measurement with a 1µF/50V M/C and a 10µF/50V T/C.
- 4 We recommend to protect the converter by a slow blow fuse in the input supply line.
- 5 Other input and output voltage may be available, please contact MINMAX.
- 6 The external components might be required to meet EMI/EMS standard for some of test items. Please contact MINMAX for the solution in detail.
- 7 Do not exceed maximum power specification when adjusting output voltage.
- 8 Specifications are subject to change without notice.

Characteristic Curves

All test conditions are at 25°C The figures are identical for MKW40-120S33

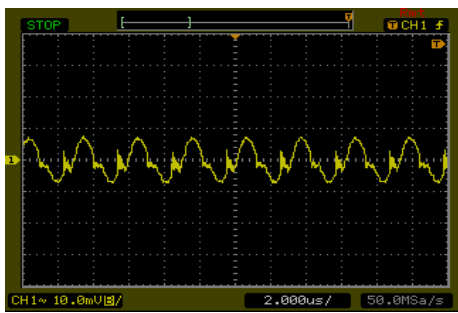
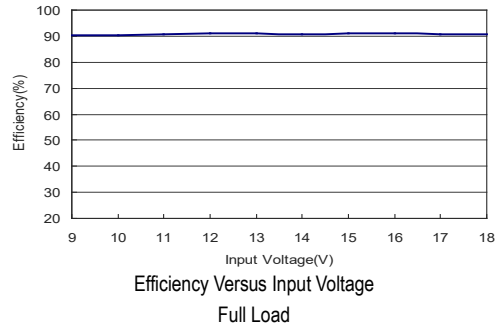
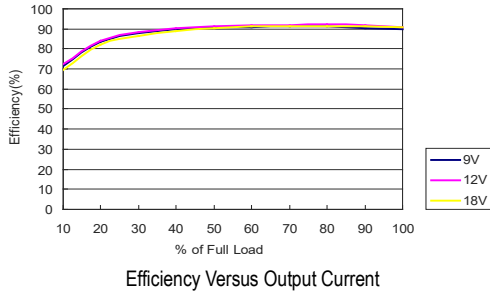

Typical Output Ripple and Noise
 $V_{in}=V_{in\ nom}$; Full Load

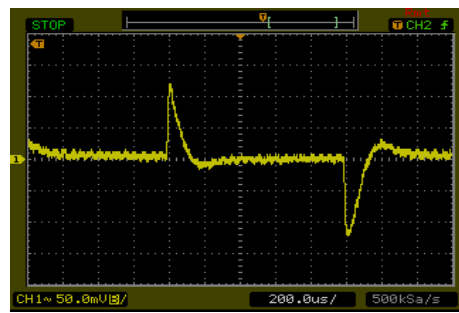

Transient Response to Dynamic Load Change
from 100% to 75% of Full Load; $V_{in}=V_{in\ nom}$

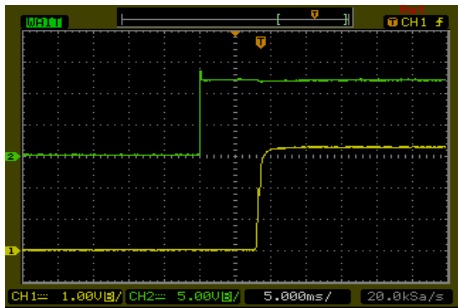

Typical Input Start-Up and Output Rise Characteristic
 $V_{in}=V_{in\ nom}$; Full Load

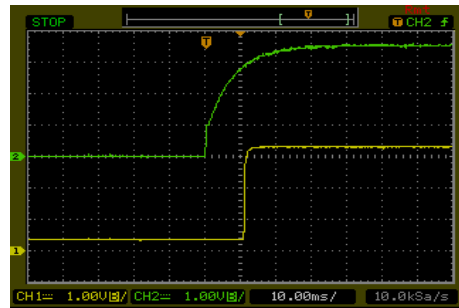

ON/OFF Voltage Start-Up and Output Rise Characteristic
 $V_{in}=V_{in\ nom}$; Full Load

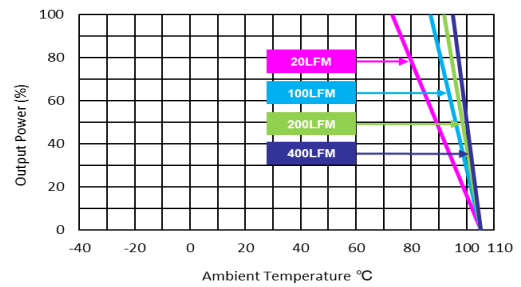
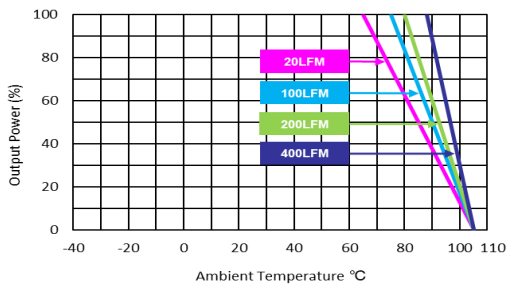

Characteristic Curves

All test conditions are at 25°C The figures are identical for MKW40-12S05

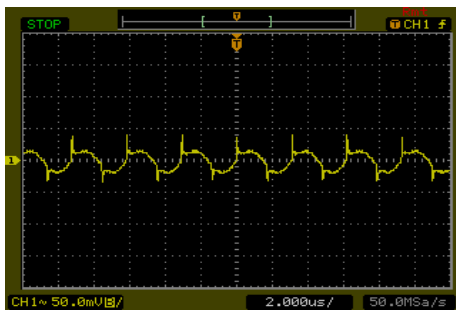
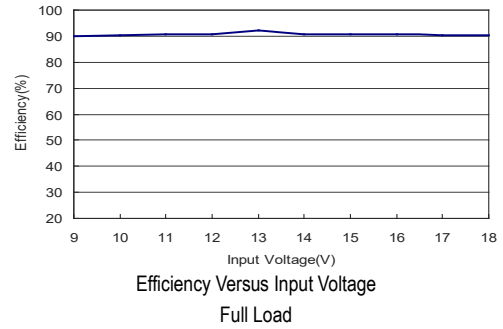
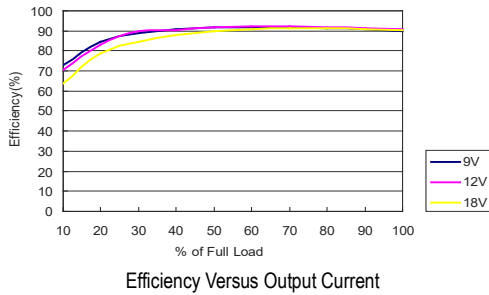

Typical Output Ripple and Noise
 $V_{in}=V_{in\ nom}$; Full Load

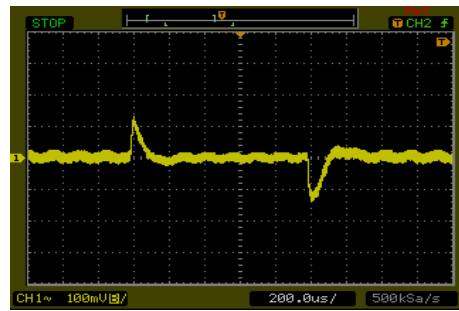

Transient Response to Dynamic Load Change
from 100% to 75% of Full Load; $V_{in}=V_{in\ nom}$

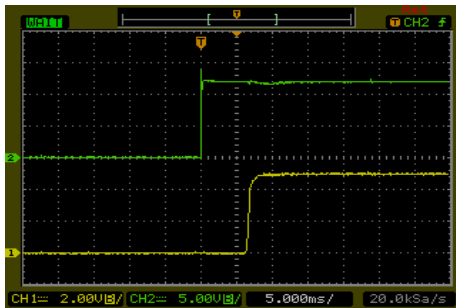

Typical Input Start-Up and Output Rise Characteristic
 $V_{in}=V_{in\ nom}$; Full Load

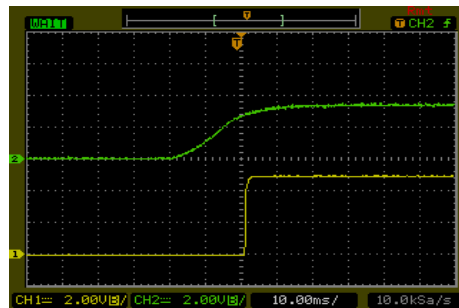

ON/OFF Voltage Start-Up and Output Rise Characteristic
 $V_{in}=V_{in\ nom}$; Full Load

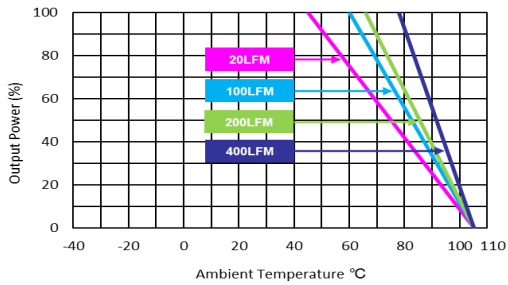

Derating Output Current Versus Ambient Temperature and Airflow
 $V_{in}=V_{in\ nom}$

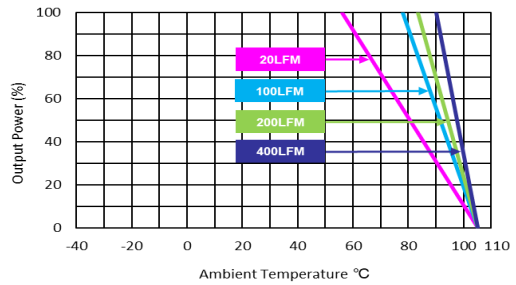

Derating Output Power Versus Ambient Temperature and Airflow
 $V_{in}=V_{in\ nom}$ (with Heatsink)

Characteristic Curves

All test conditions are at 25°C. The figures are identical for MKW40-12S12

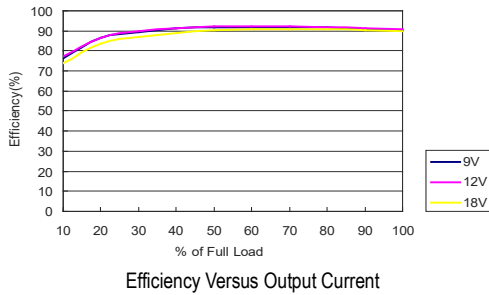

Efficiency Versus Output Current

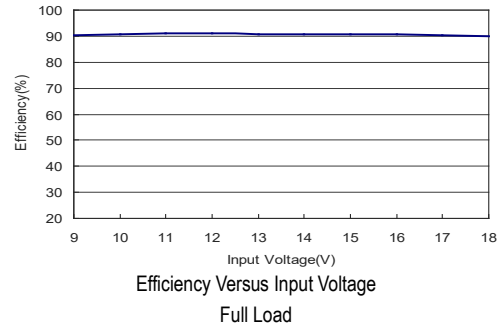

Efficiency Versus Input Voltage
Full Load

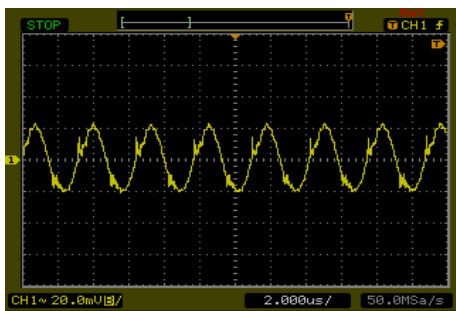

Typical Output Ripple and Noise
 $V_{in}=V_{in\ nom}$; Full Load

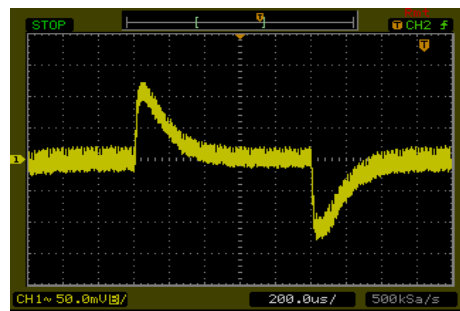

Transient Response to Dynamic Load Change
from 100% to 75% of Full Load; $V_{in}=V_{in\ nom}$

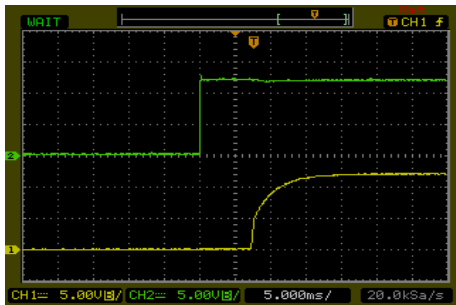

Typical Input Start-Up and Output Rise Characteristic
 $V_{in}=V_{in\ nom}$; Full Load

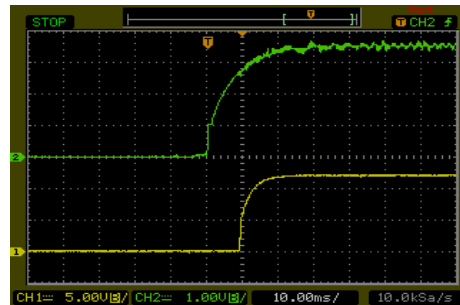

ON/OFF Voltage Start-Up and Output Rise Characteristic
 $V_{in}=V_{in\ nom}$; Full Load

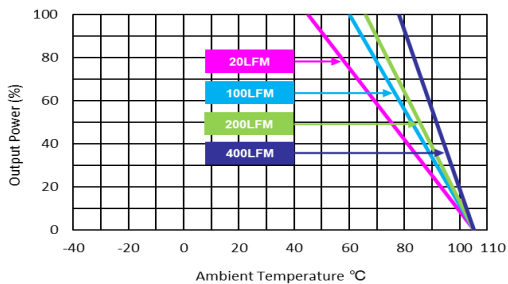

Derating Output Current Versus Ambient Temperature and Airflow
 $V_{in}=V_{in\ nom}$

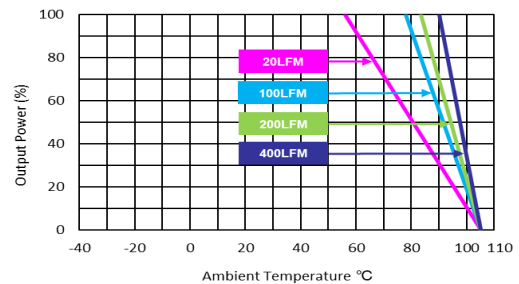

Derating Output Power Versus Ambient Temperature and Airflow
 $V_{in}=V_{in\ nom}$ (with Heatsink)

Characteristic Curves

All test conditions are at 25°C. The figures are identical for MKW40-12S15

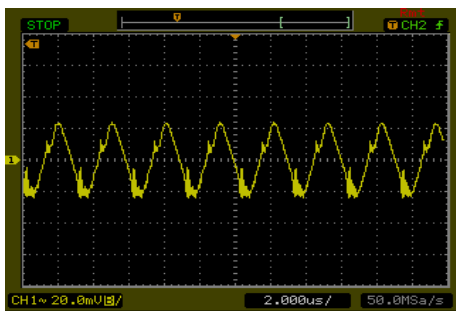
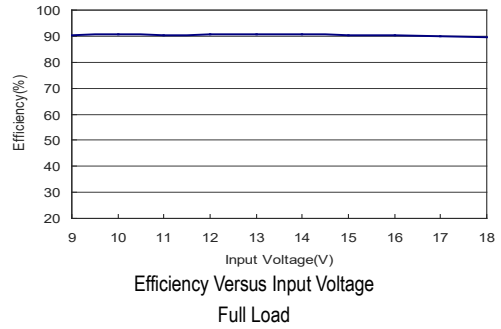
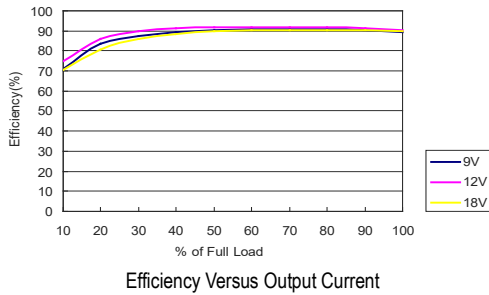

Typical Output Ripple and Noise
 $V_{in}=V_{in\ nom}$; Full Load

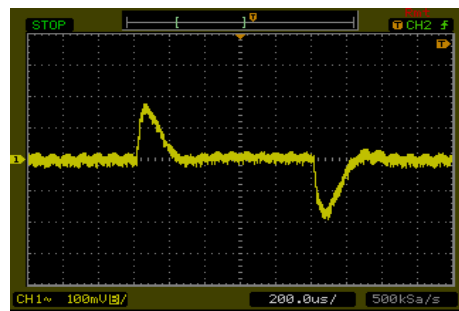

Transient Response to Dynamic Load Change
from 100% to 75% of Full Load; $V_{in}=V_{in\ nom}$

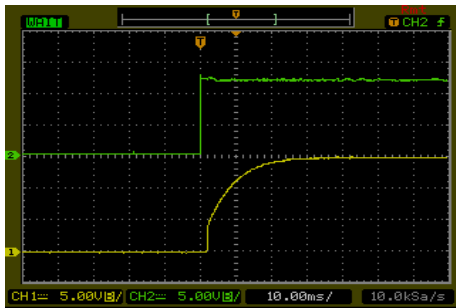

Typical Input Start-Up and Output Rise Characteristic
 $V_{in}=V_{in\ nom}$; Full Load

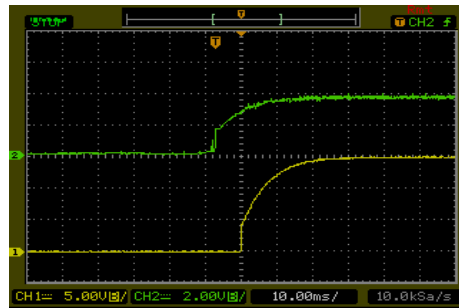

ON/OFF Voltage Start-Up and Output Rise Characteristic
 $V_{in}=V_{in\ nom}$; Full Load

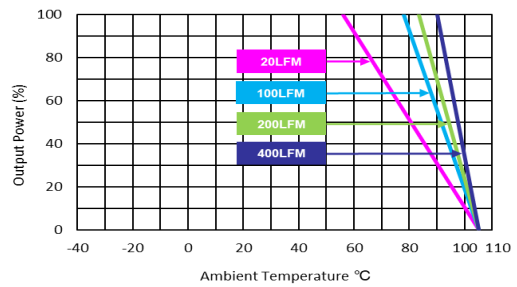
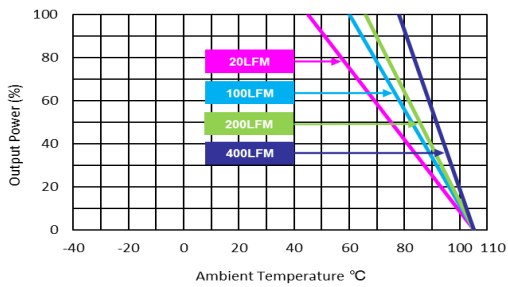

Characteristic Curves

All test conditions are at 25°C The figures are identical for MKW40-12S24

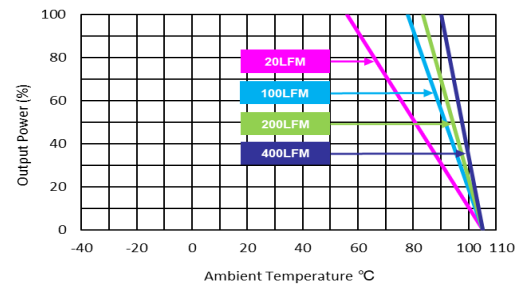
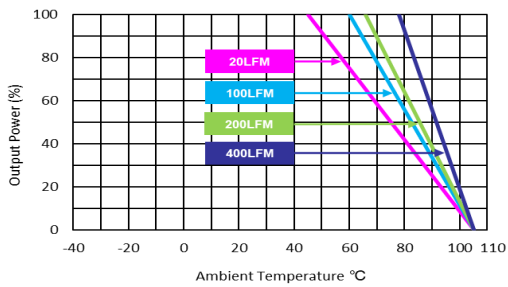
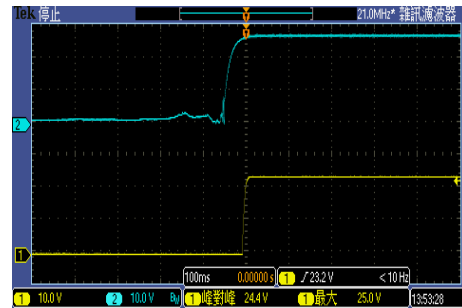
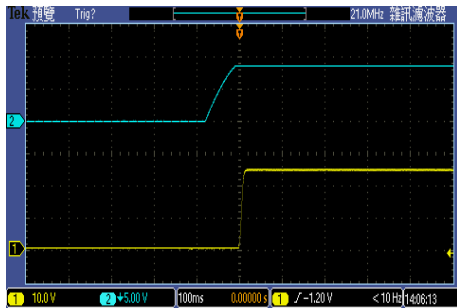
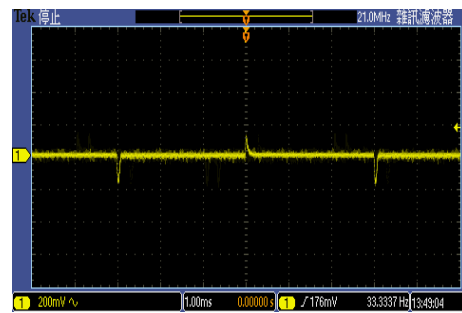
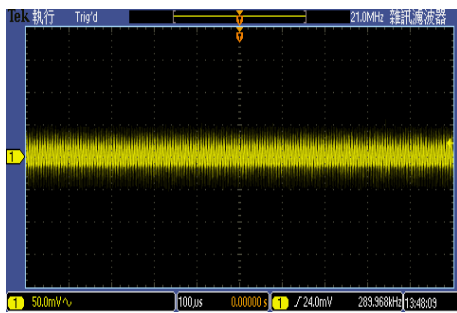
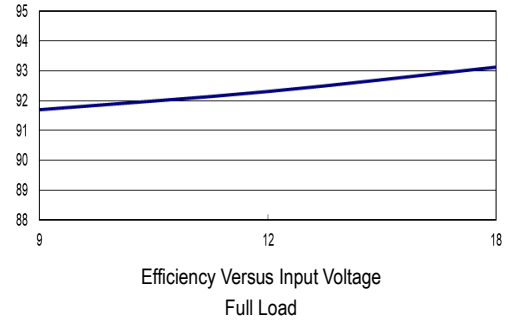
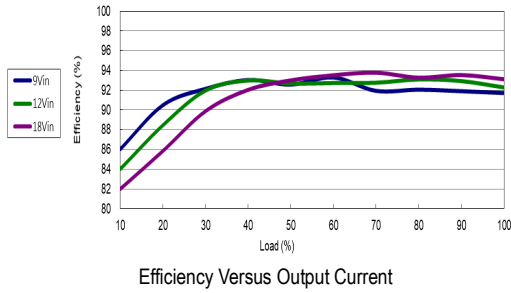

Characteristic Curves

All test conditions are at 25°C. The figures are identical for MKW40-12D12

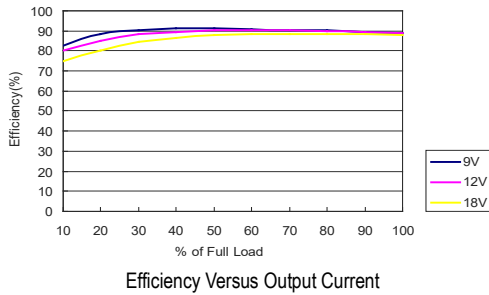

Efficiency Versus Output Current

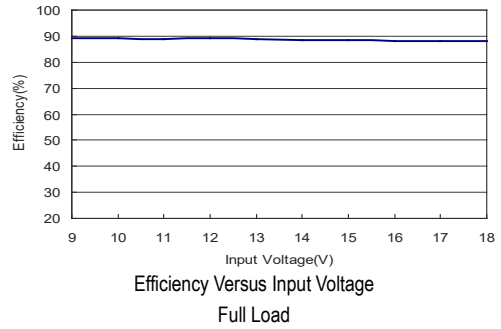

Efficiency Versus Input Voltage Full Load

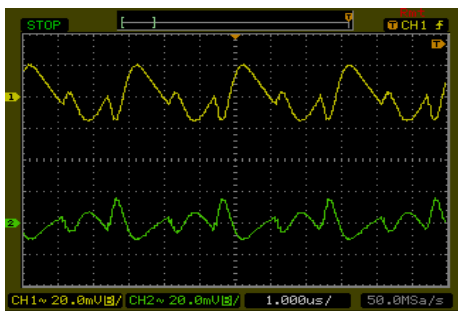

Typical Output Ripple and Noise
 $V_{in}=V_{in\ nom}$; Full Load

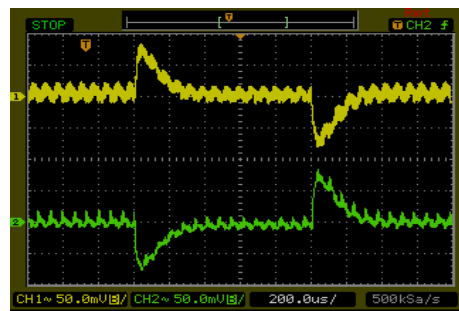

Transient Response to Dynamic Load Change
from 100% to 75% of Full Load; $V_{in}=V_{in\ nom}$

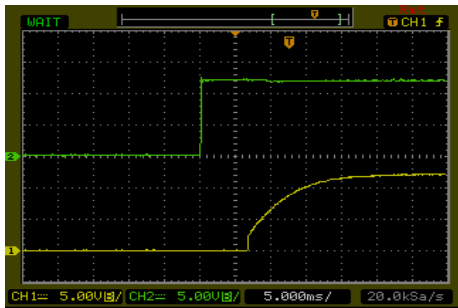

Typical Input Start-Up and Output Rise Characteristic
 $V_{in}=V_{in\ nom}$; Full Load

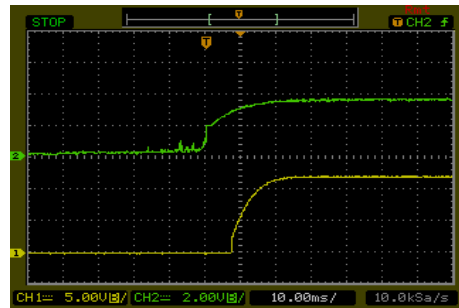

ON/OFF Voltage Start-Up and Output Rise Characteristic
 $V_{in}=V_{in\ nom}$; Full Load

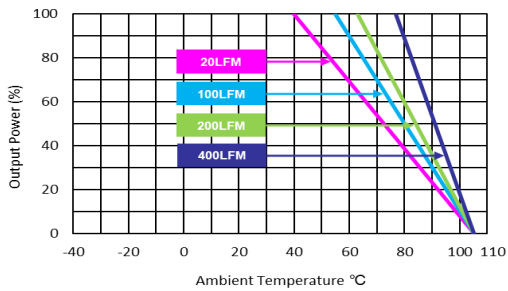

Derating Output Current Versus Ambient Temperature and Airflow
 $V_{in}=V_{in\ nom}$

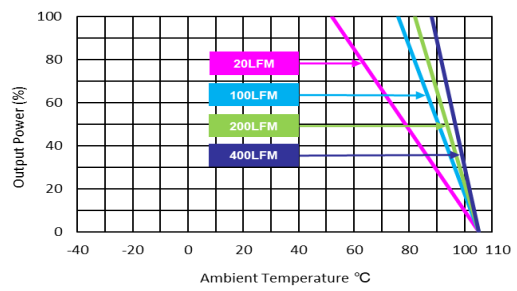

Derating Output Power Versus Ambient Temperature and Airflow
 $V_{in}=V_{in\ nom}$ (with Heatsink)

Characteristic Curves

All test conditions are at 25°C The figures are identical for MKW40-12D15

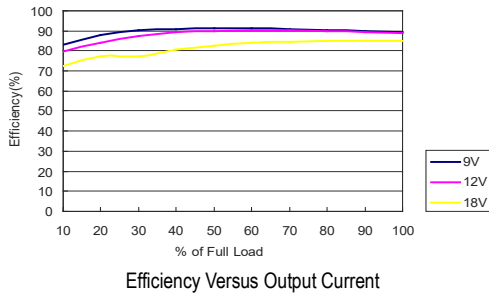

Efficiency Versus Output Current

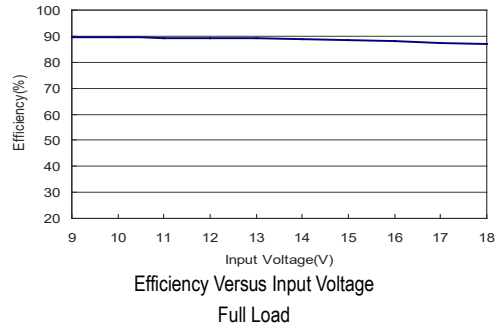

Efficiency Versus Input Voltage
Full Load



Typical Output Ripple and Noise
 $V_{in}=V_{in\ nom}$; Full Load

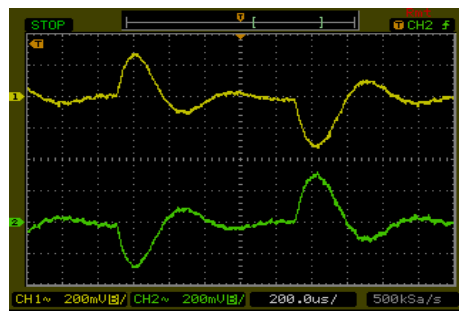

Transient Response to Dynamic Load Change
from 100% to 75% of Full Load; $V_{in}=V_{in\ nom}$

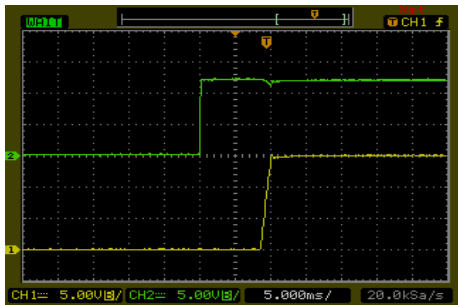

Typical Input Start-Up and Output Rise Characteristic
 $V_{in}=V_{in\ nom}$; Full Load

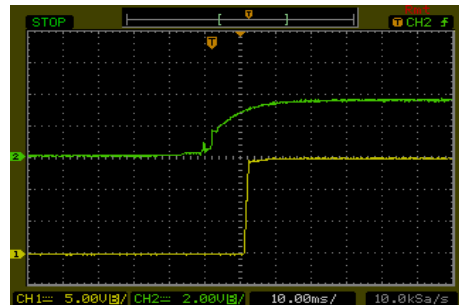

ON/OFF Voltage Start-Up and Output Rise Characteristic
 $V_{in}=V_{in\ nom}$; Full Load

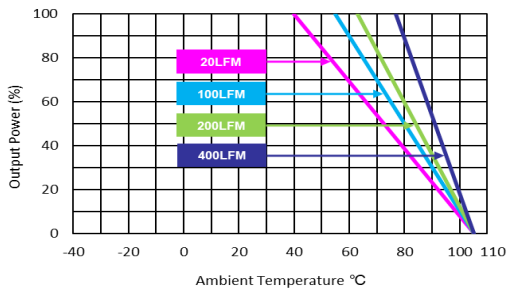

Derating Output Current Versus Ambient Temperature and Airflow
 $V_{in}=V_{in\ nom}$

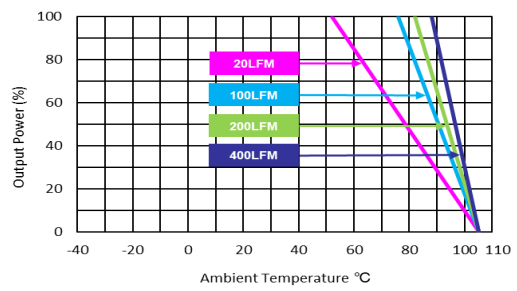

Derating Output Power Versus Ambient Temperature and Airflow
 $V_{in}=V_{in\ nom}$ (with Heatsink)

Characteristic Curves

All test conditions are at 25°C. The figures are identical for MKW40-24S033

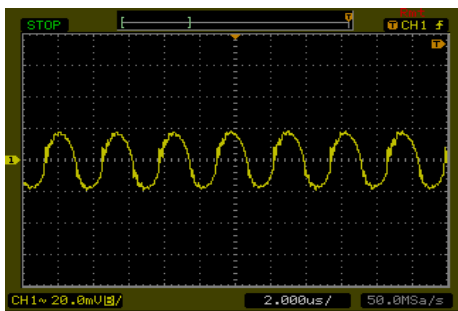
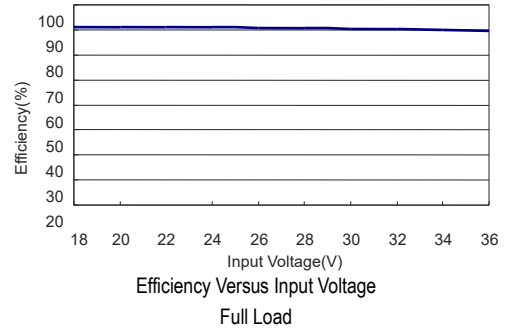
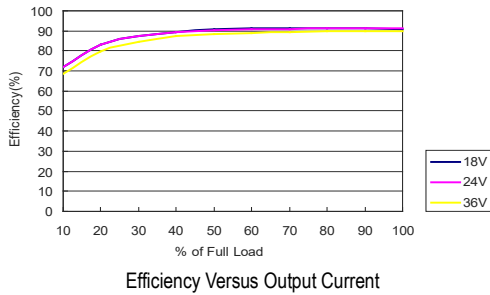

Typical Output Ripple and Noise
 $V_{in}=V_{in\ nom}$; Full Load

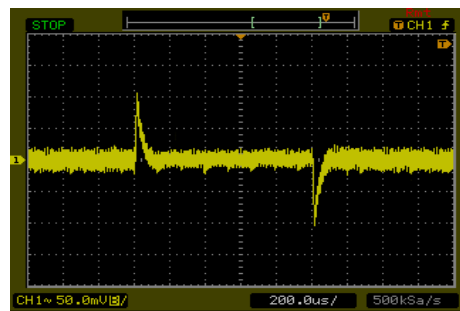

Transient Response to Dynamic Load Change
from 100% to 75% of Full Load; $V_{in}=V_{in\ nom}$

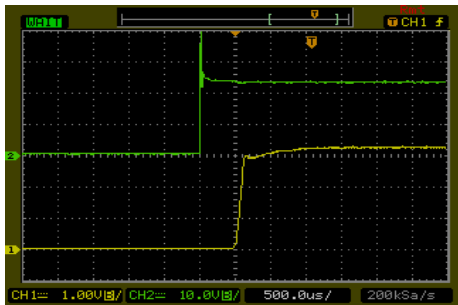

Typical Input Start-Up and Output Rise Characteristic
 $V_{in}=V_{in\ nom}$; Full Load

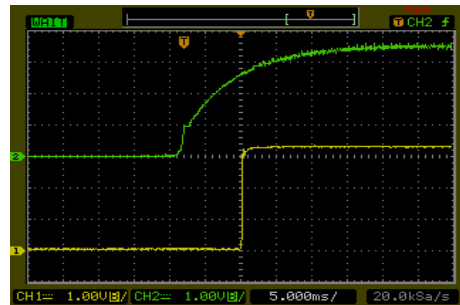

ON/OFF Voltage Start-Up and Output Rise Characteristic
 $V_{in}=V_{in\ nom}$; Full Load

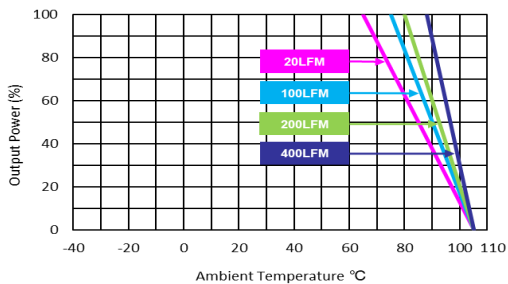

Derating Output Current Versus Ambient Temperature and Airflow
 $V_{in}=V_{in\ nom}$

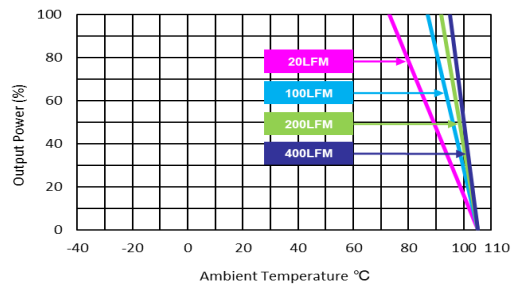

Derating Output Power Versus Ambient Temperature and Airflow
 $V_{in}=V_{in\ nom}$ (with Heatsink)

Characteristic Curves

All test conditions are at 25°C The figures are identical for MKW40-24S05

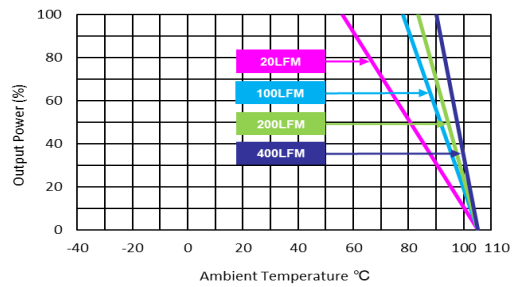
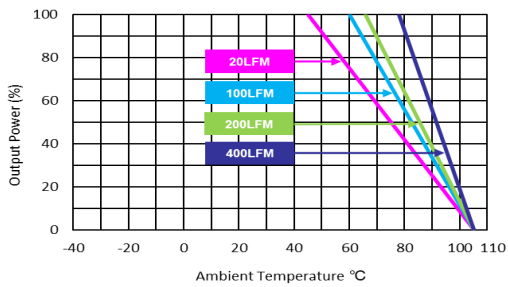
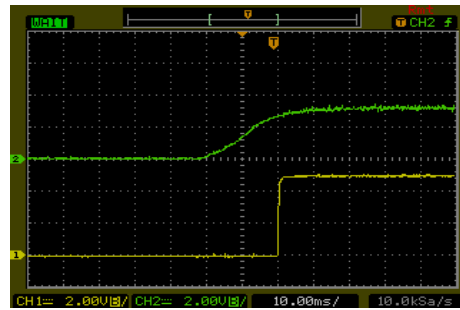
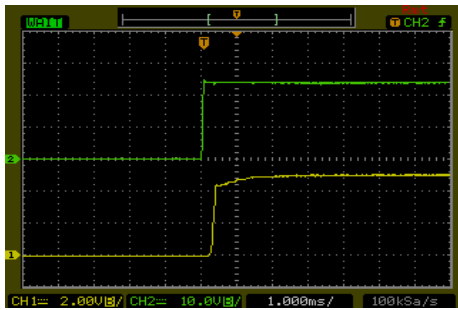
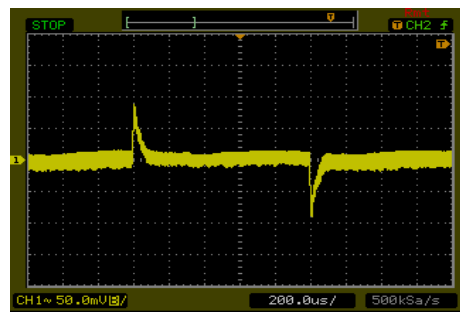
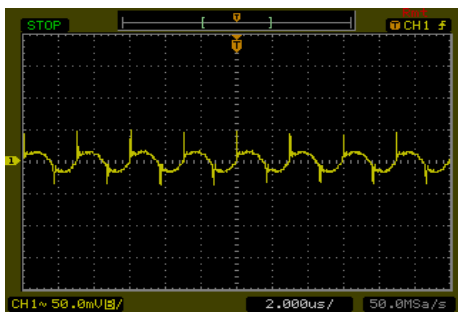
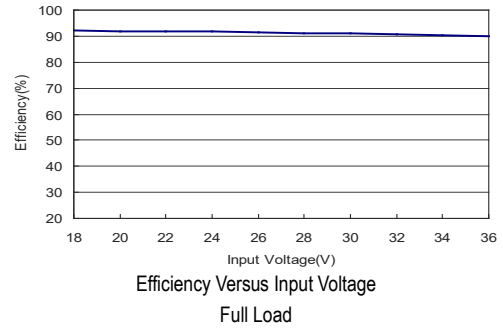
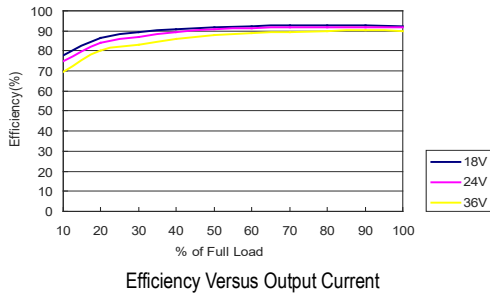

Characteristic Curves

All test conditions are at 25°C. The figures are identical for MKW40-24S12

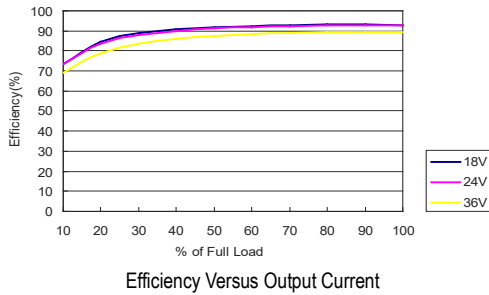

Efficiency Versus Output Current

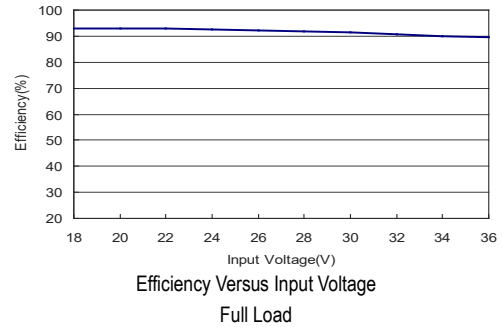

Efficiency Versus Input Voltage Full Load

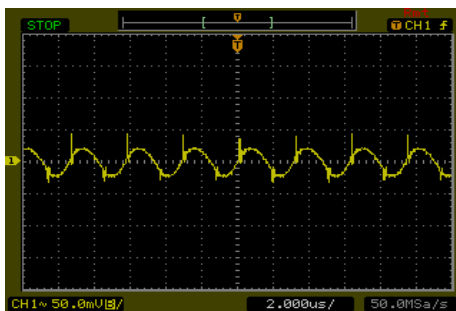

Typical Output Ripple and Noise
 $V_{in}=V_{in\ nom}$; Full Load

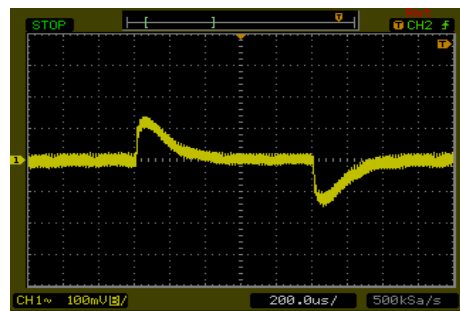

Transient Response to Dynamic Load Change
from 100% to 75% of Full Load; $V_{in}=V_{in\ nom}$

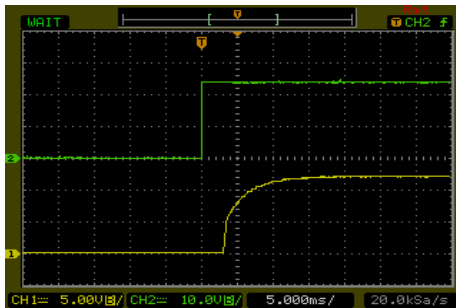

Typical Input Start-Up and Output Rise Characteristic
 $V_{in}=V_{in\ nom}$; Full Load

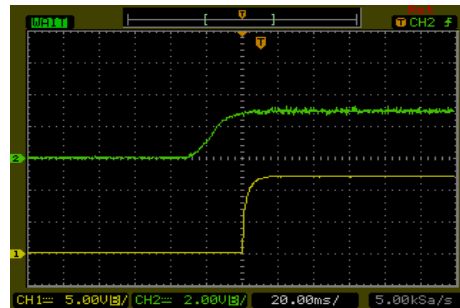

ON/OFF Voltage Start-Up and Output Rise Characteristic
 $V_{in}=V_{in\ nom}$; Full Load

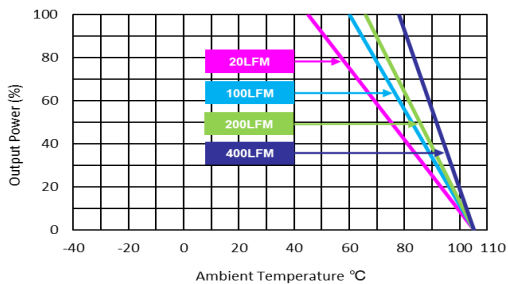

Derating Output Current Versus Ambient Temperature and Airflow
 $V_{in}=V_{in\ nom}$

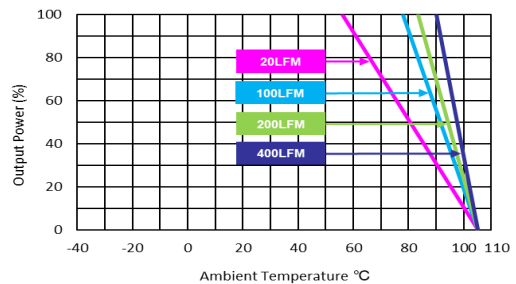

Derating Output Power Versus Ambient Temperature and Airflow
 $V_{in}=V_{in\ nom}$ (with Heatsink)

Characteristic Curves

All test conditions are at 25°C. The figures are identical for MKW40-24S15

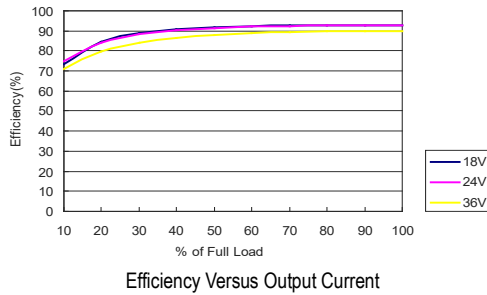

Efficiency Versus Output Current

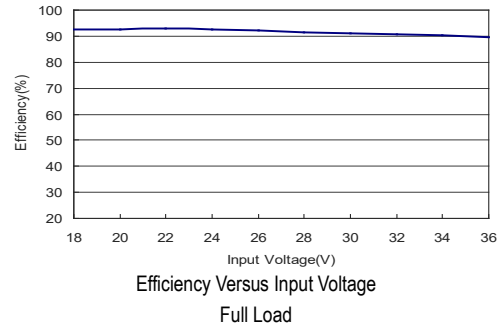

Efficiency Versus Input Voltage Full Load

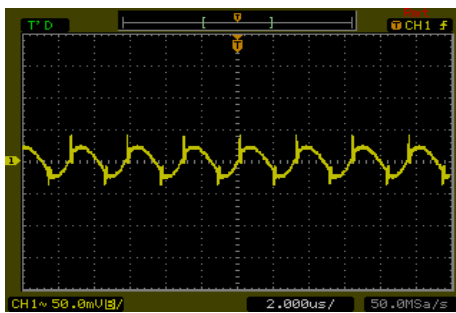

Typical Output Ripple and Noise
 $V_{in}=V_{in\ nom}$; Full Load

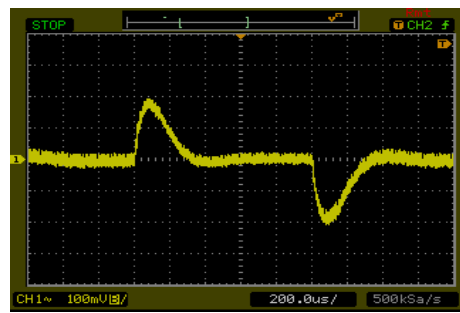

Transient Response to Dynamic Load Change
from 100% to 75% of Full Load; $V_{in}=V_{in\ nom}$

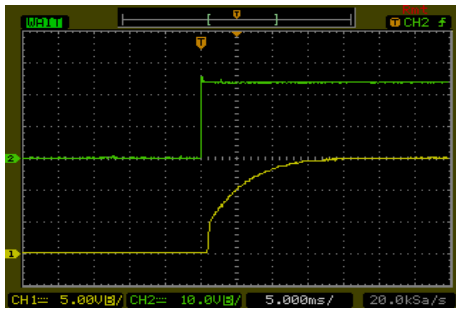

Typical Input Start-Up and Output Rise Characteristic
 $V_{in}=V_{in\ nom}$; Full Load

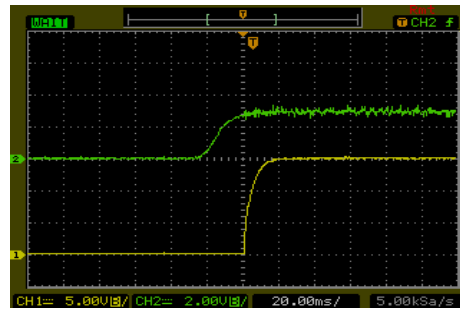

ON/OFF Voltage Start-Up and Output Rise Characteristic
 $V_{in}=V_{in\ nom}$; Full Load

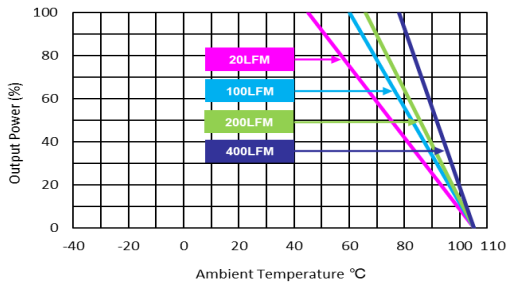

Derating Output Current Versus Ambient Temperature and Airflow
 $V_{in}=V_{in\ nom}$

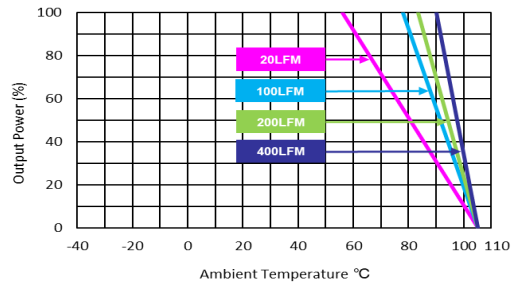

Derating Output Power Versus Ambient Temperature and Airflow
 $V_{in}=V_{in\ nom}$ (with Heatsink)

Characteristic Curves

All test conditions are at 25°C The figures are identical for MKW40-24S24

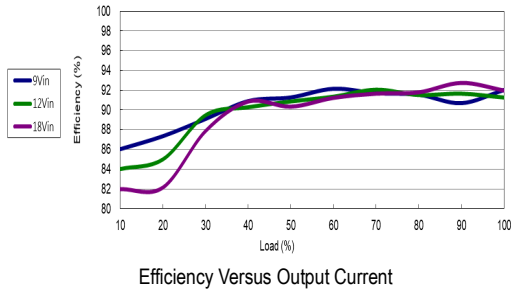

Efficiency Versus Output Current

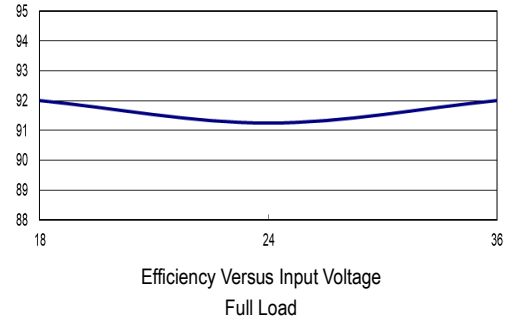

Efficiency Versus Input Voltage Full Load

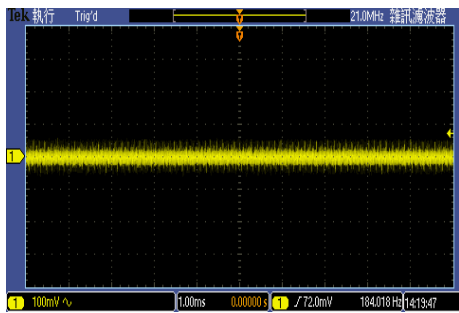

Typical Output Ripple and Noise
 $V_{in}=V_{in\ nom}$; Full Load

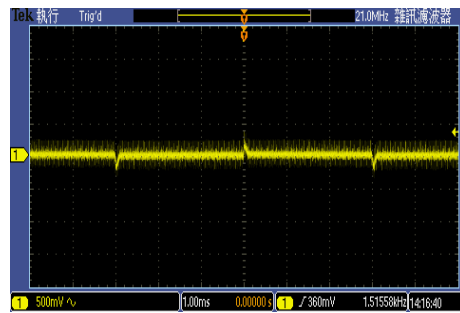

Transient Response to Dynamic Load Change
from 100% to 75% of Full Load ; $V_{in}=V_{in\ nom}$

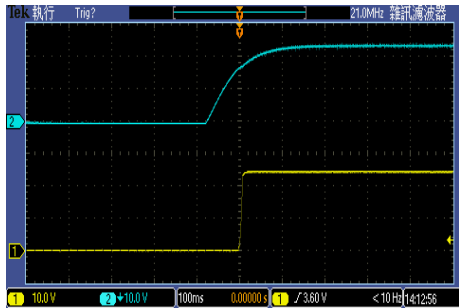

Typical Input Start-Up and Output Rise Characteristic
 $V_{in}=V_{in\ nom}$; Full Load

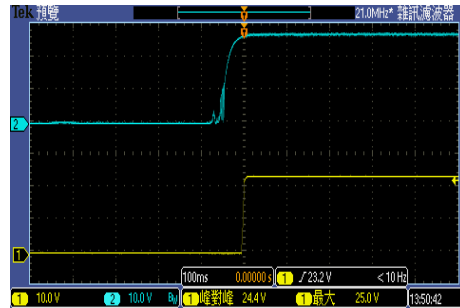

ON/OFF Voltage Start-Up and Output Rise Characteristic
 $V_{in}=V_{in\ nom}$; Full Load

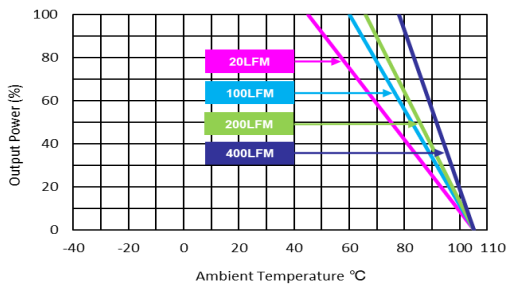

Derating Output Current Versus Ambient Temperature and Airflow
 $V_{in}=V_{in\ nom}$

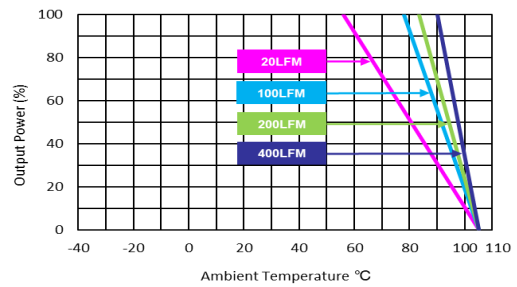

Derating Output Power Versus Ambient Temperature and Airflow
 $V_{in}=V_{in\ nom}$ (with Heatsink)

Characteristic Curves

All test conditions are at 25°C. The figures are identical for MKW40-24D12

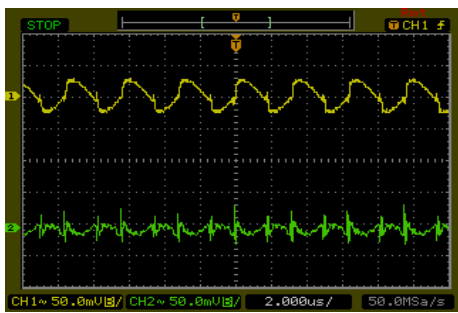
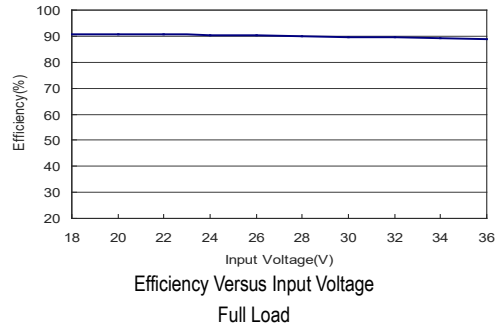
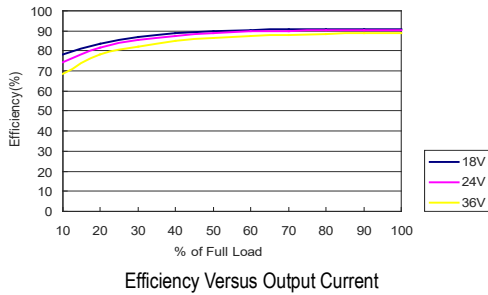

Typical Output Ripple and Noise
 $V_{in}=V_{in\ nom}$; Full Load

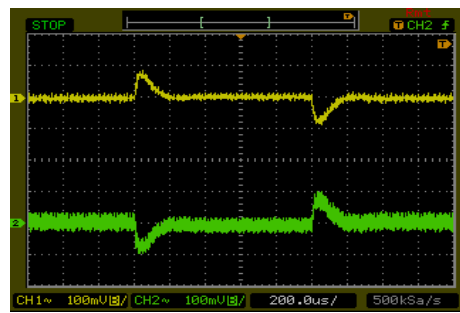

Transient Response to Dynamic Load Change
from 100% to 75% of Full Load; $V_{in}=V_{in\ nom}$

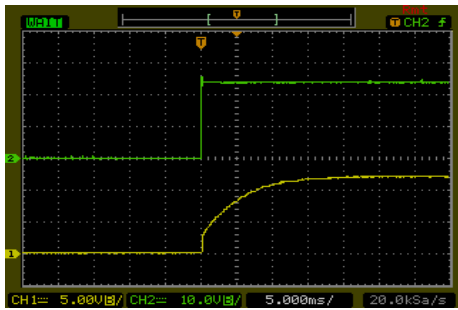

Typical Input Start-Up and Output Rise Characteristic
 $V_{in}=V_{in\ nom}$; Full Load

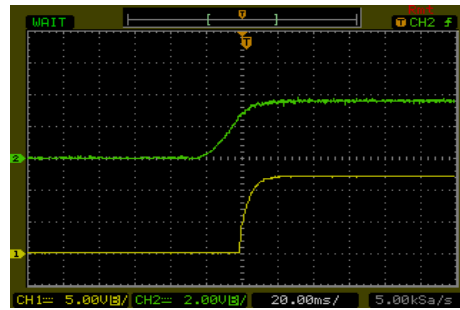

ON/OFF Voltage Start-Up and Output Rise Characteristic
 $V_{in}=V_{in\ nom}$; Full Load

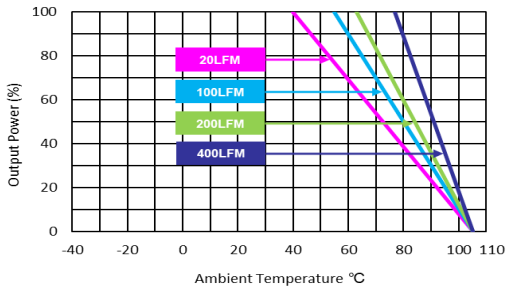

Derating Output Current Versus Ambient Temperature and Airflow
 $V_{in}=V_{in\ nom}$

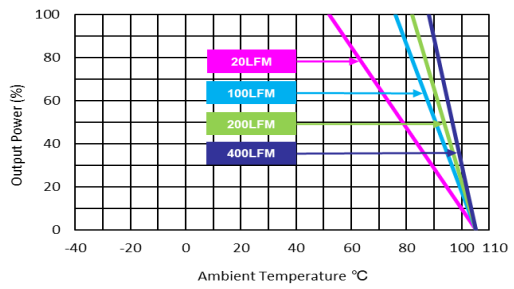

Derating Output Power Versus Ambient Temperature and Airflow
 $V_{in}=V_{in\ nom}$ (with Heatsink)

Characteristic Curves

All test conditions are at 25°C. The figures are identical for MKW40-24D15

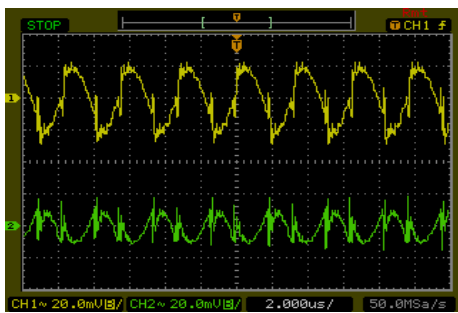
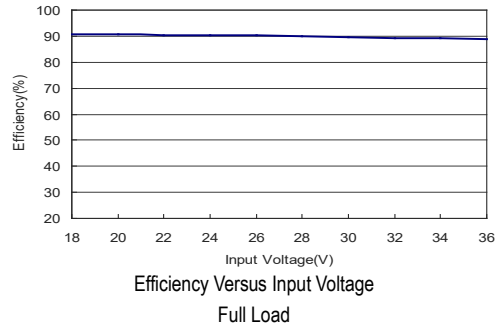
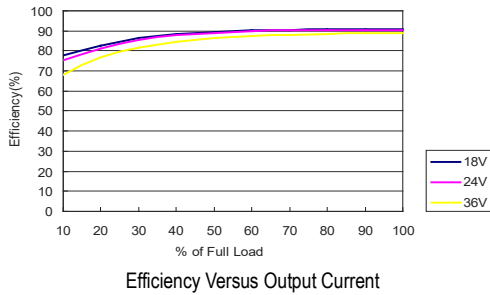

Typical Output Ripple and Noise
 $V_{in}=V_{in\ nom}$; Full Load

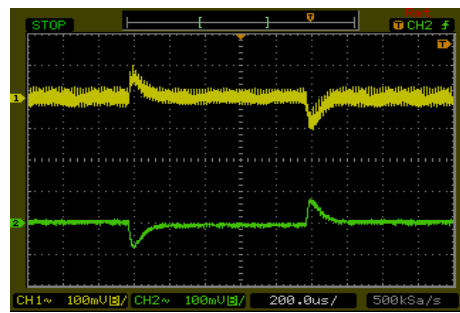

Transient Response to Dynamic Load Change
from 100% to 75% of Full Load; $V_{in}=V_{in\ nom}$

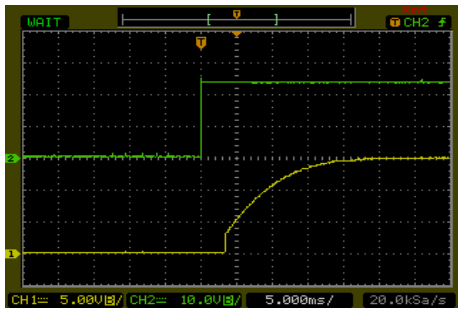

Typical Input Start-Up and Output Rise Characteristic
 $V_{in}=V_{in\ nom}$; Full Load

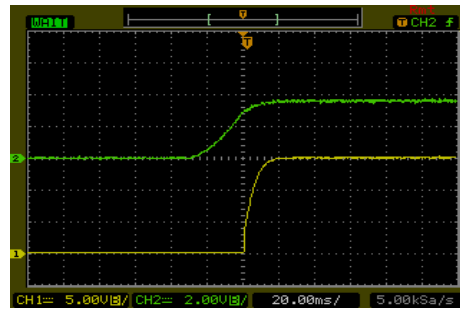

ON/OFF Voltage Start-Up and Output Rise Characteristic
 $V_{in}=V_{in\ nom}$; Full Load

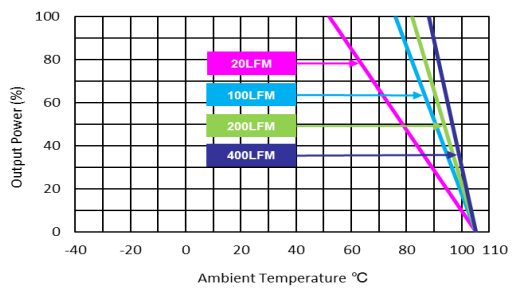
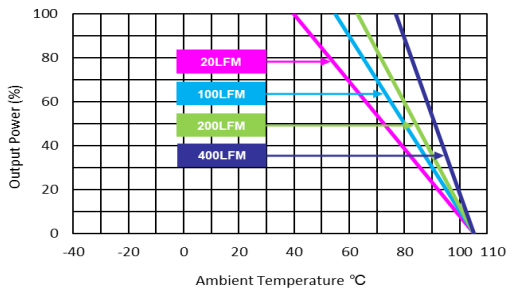

Characteristic Curves

All test conditions are at 25°C. The figures are identical for MKW40-48S033

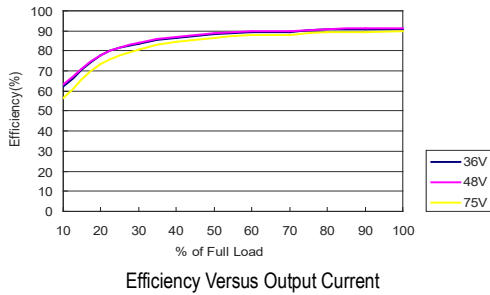

Efficiency Versus Output Current

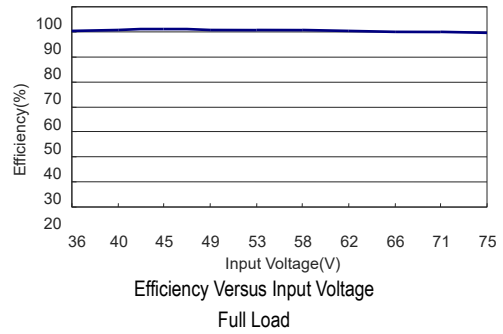

Efficiency Versus Input Voltage
Full Load

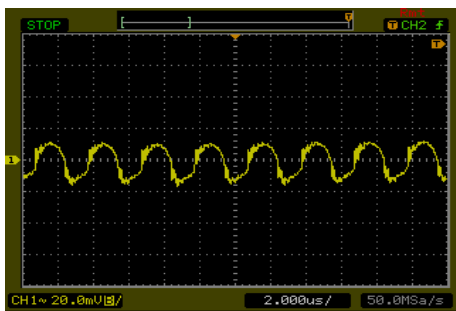

Typical Output Ripple and Noise
 $V_{in}=V_{in\ nom}$; Full Load

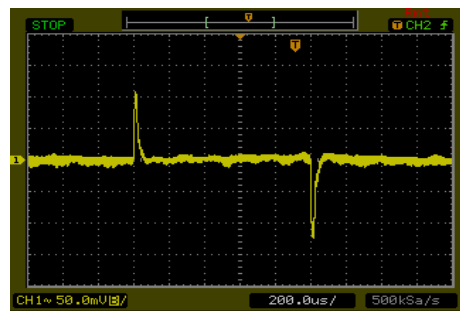

Transient Response to Dynamic Load Change
from 100% to 75% of Full Load; $V_{in}=V_{in\ nom}$

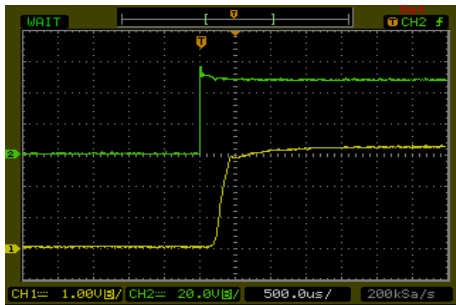

Typical Input Start-Up and Output Rise Characteristic
 $V_{in}=V_{in\ nom}$; Full Load

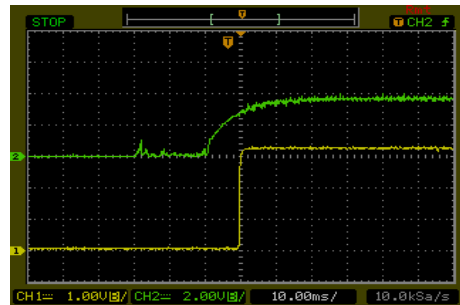

ON/OFF Voltage Start-Up and Output Rise Characteristic
 $V_{in}=V_{in\ nom}$; Full Load

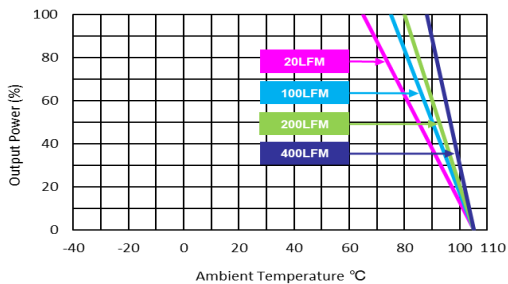

Derating Output Current Versus Ambient Temperature and Airflow
 $V_{in}=V_{in\ nom}$

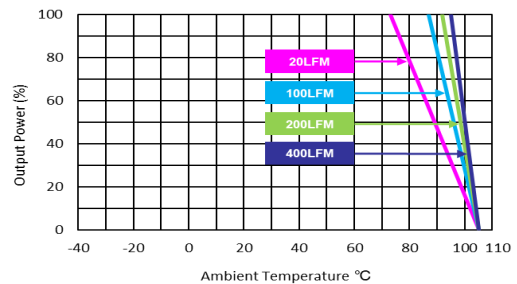

Derating Output Power Versus Ambient Temperature and Airflow
 $V_{in}=V_{in\ nom}$ (with Heatsink)

Characteristic Curves

All test conditions are at 25°C. The figures are identical for MKW40-48S05

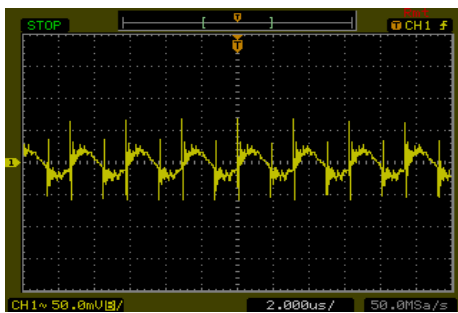
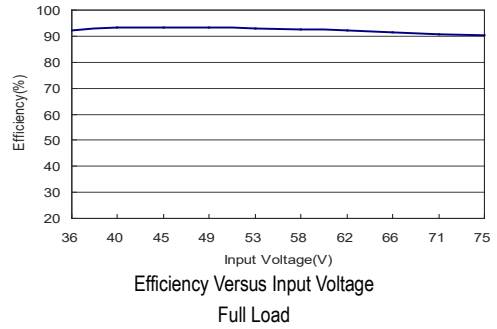
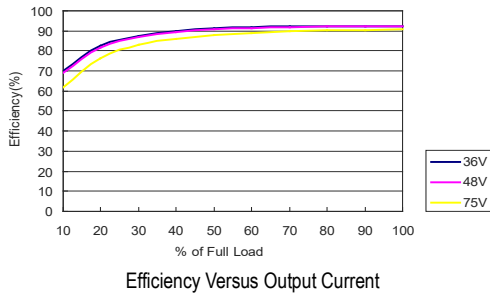

Typical Output Ripple and Noise
 $V_{in}=V_{in\ nom}$; Full Load

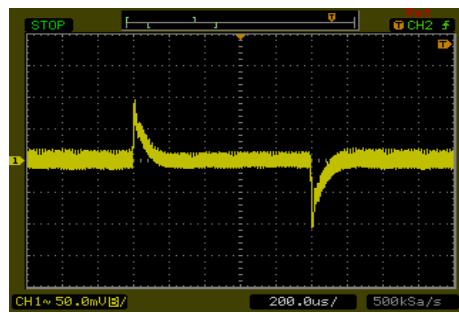

Transient Response to Dynamic Load Change
from 100% to 75% of Full Load; $V_{in}=V_{in\ nom}$

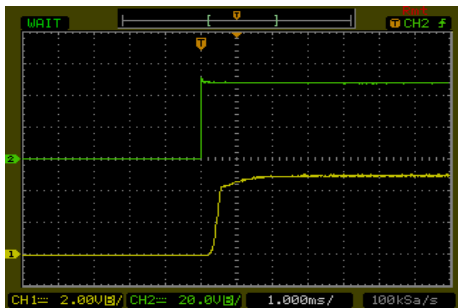

Typical Input Start-Up and Output Rise Characteristic
 $V_{in}=V_{in\ nom}$; Full Load

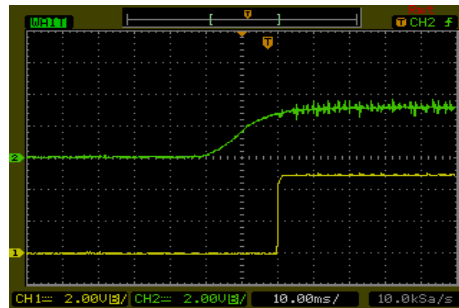

ON/OFF Voltage Start-Up and Output Rise Characteristic
 $V_{in}=V_{in\ nom}$; Full Load

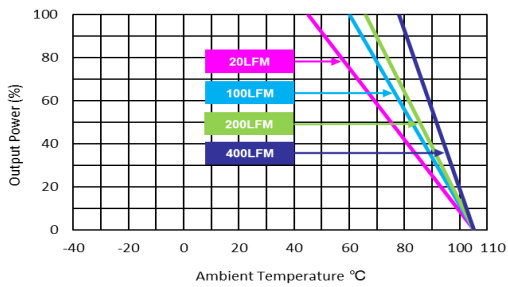

Derating Output Current Versus Ambient Temperature and Airflow
 $V_{in}=V_{in\ nom}$

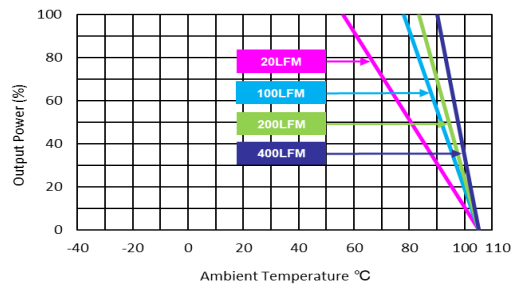

Derating Output Power Versus Ambient Temperature and Airflow
 $V_{in}=V_{in\ nom}$ (with Heatsink)

Characteristic Curves

All test conditions are at 25°C. The figures are identical for MKW40-48S12

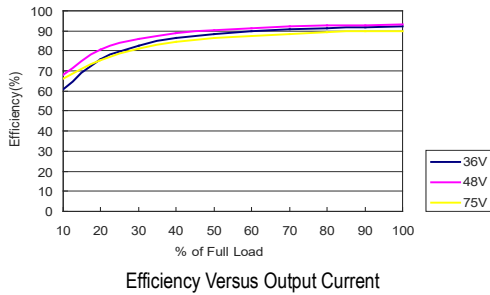

Efficiency Versus Output Current

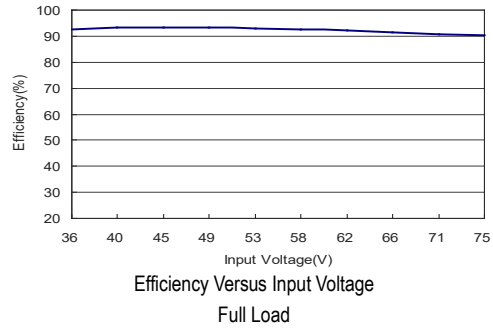

Efficiency Versus Input Voltage
Full Load

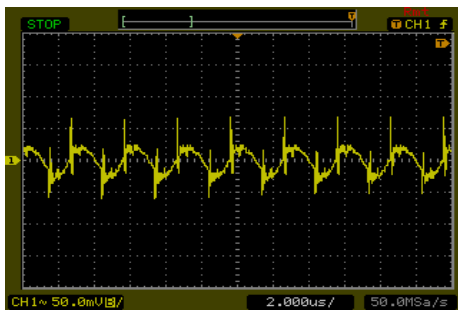

Typical Output Ripple and Noise
 $V_{in}=V_{in\ nom}$; Full Load

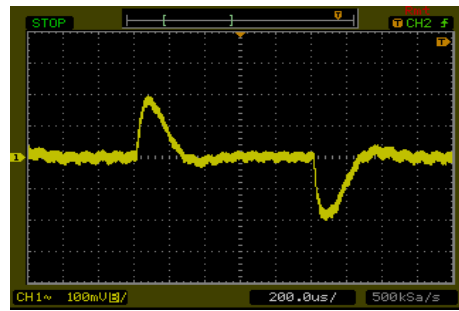

Transient Response to Dynamic Load Change
from 100% to 75% of Full Load; $V_{in}=V_{in\ nom}$

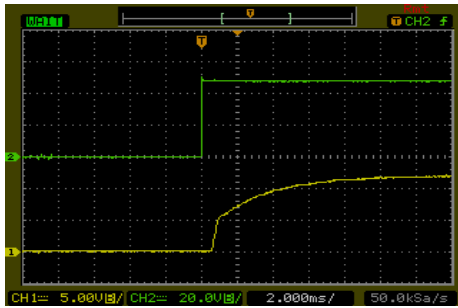

Typical Input Start-Up and Output Rise Characteristic
 $V_{in}=V_{in\ nom}$; Full Load

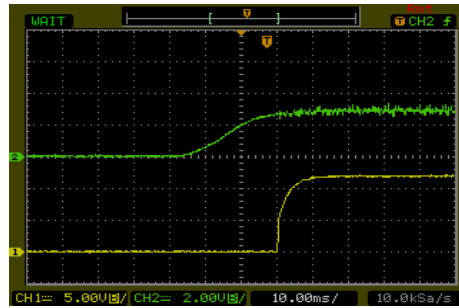

ON/OFF Voltage Start-Up and Output Rise Characteristic
 $V_{in}=V_{in\ nom}$; Full Load

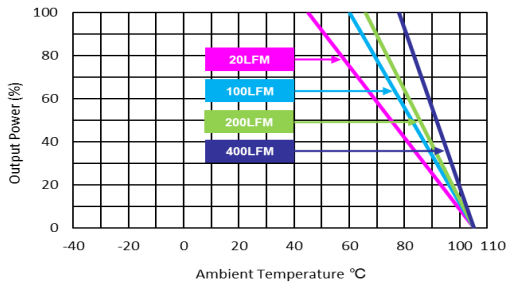

Derating Output Current Versus Ambient Temperature and Airflow
 $V_{in}=V_{in\ nom}$

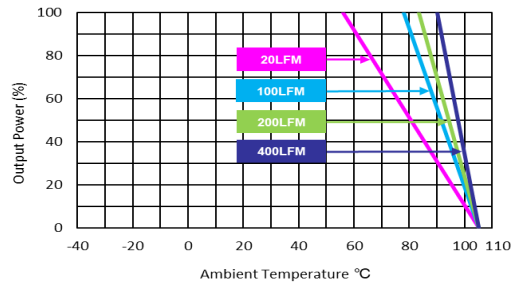

Derating Output Power Versus Ambient Temperature and Airflow
 $V_{in}=V_{in\ nom}$ (with Heatsink)

Characteristic Curves

All test conditions are at 25°C. The figures are identical for MKW40-48S15

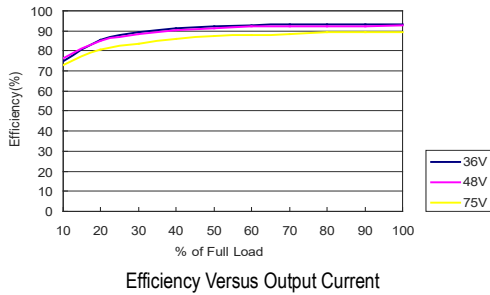

Efficiency Versus Output Current

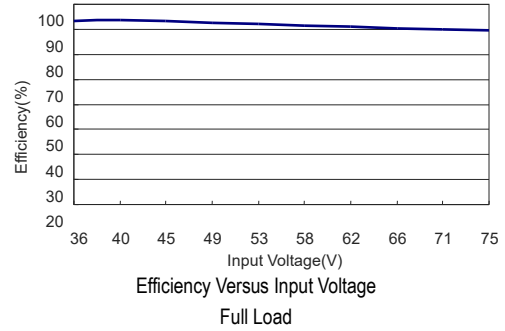

Efficiency Versus Input Voltage
Full Load

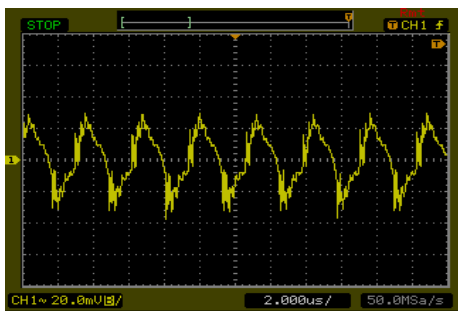

Typical Output Ripple and Noise
 $V_{in} = V_{in\ nom}$; Full Load

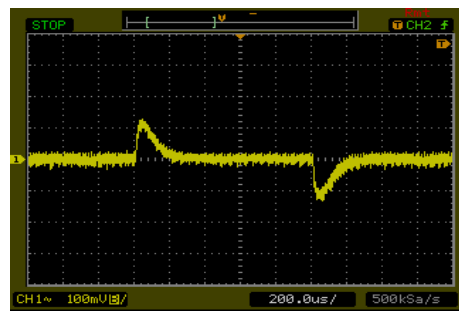

Transient Response to Dynamic Load Change
from 100% to 75% of Full Load; $V_{in} = V_{in\ nom}$

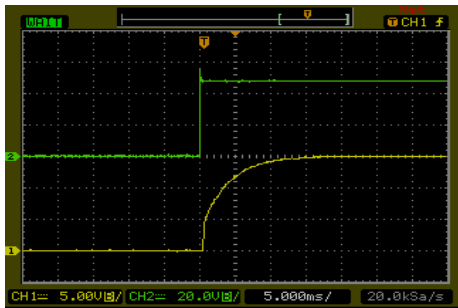

Typical Input Start-Up and Output Rise Characteristic
 $V_{in} = V_{in\ nom}$; Full Load

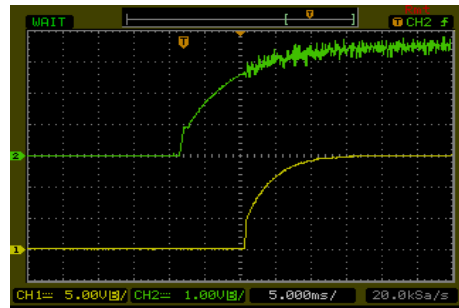

ON/OFF Voltage Start-Up and Output Rise Characteristic
 $V_{in} = V_{in\ nom}$; Full Load

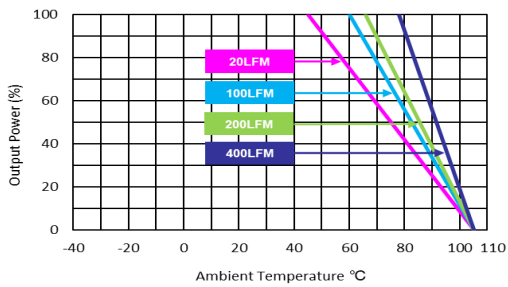

Derating Output Current Versus Ambient Temperature and Airflow
 $V_{in} = V_{in\ nom}$

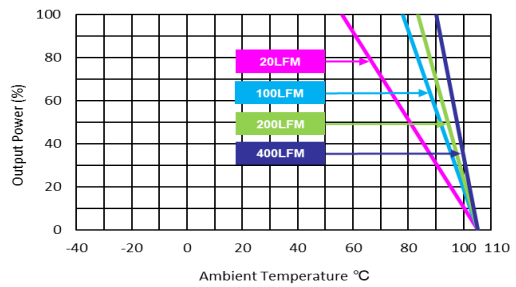

Derating Output Power Versus Ambient Temperature and Airflow
 $V_{in} = V_{in\ nom}$ (with Heatsink)

Characteristic Curves

All test conditions are at 25°C. The figures are identical for MKW40-48S24

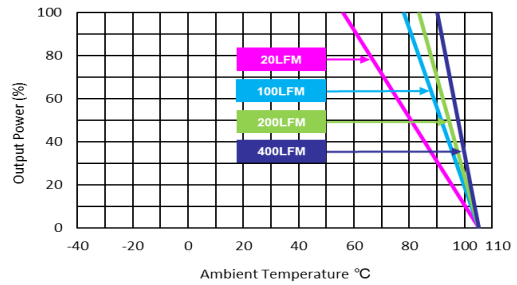
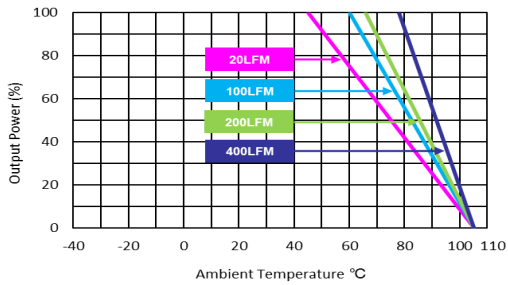
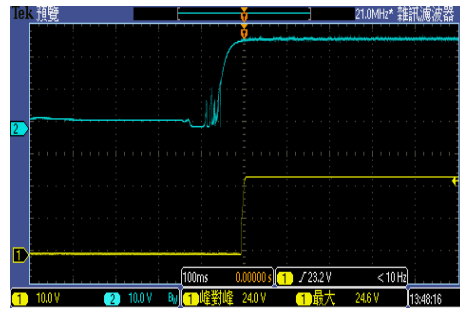
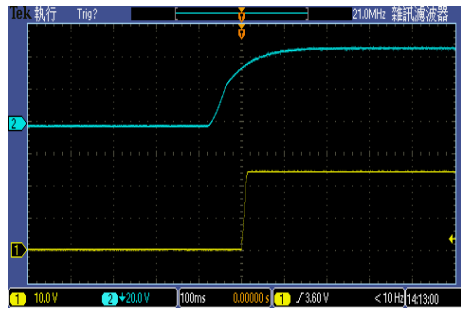
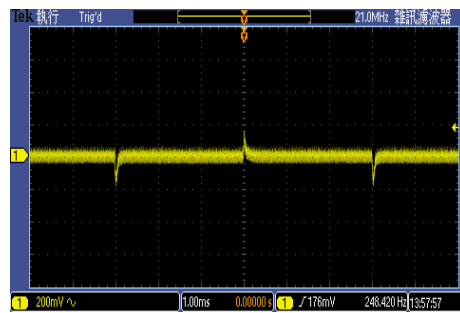
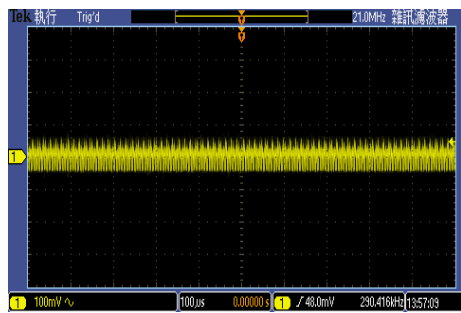
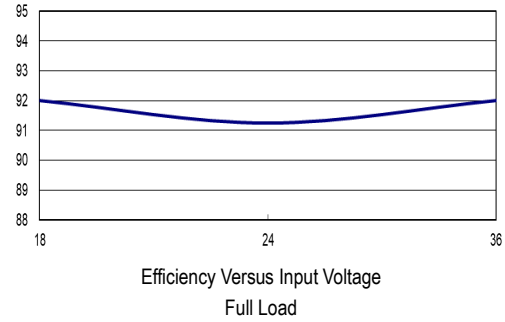
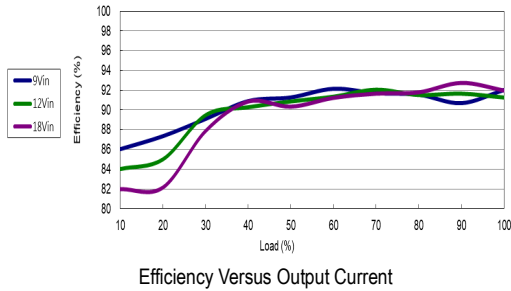

Characteristic Curves

All test conditions are at 25°C. The figures are identical for MKW40-48D12

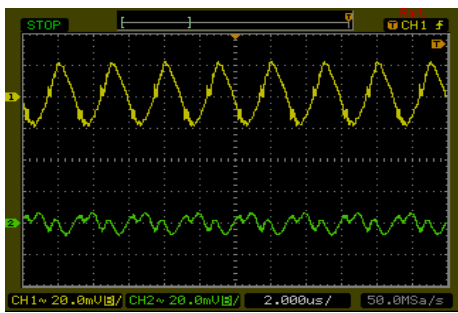
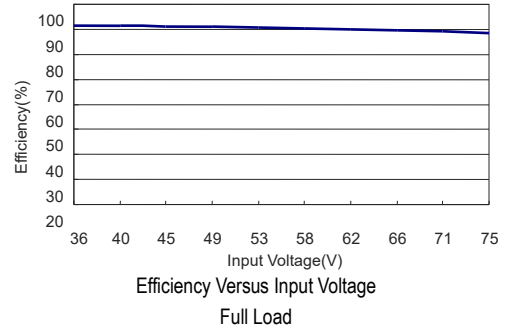
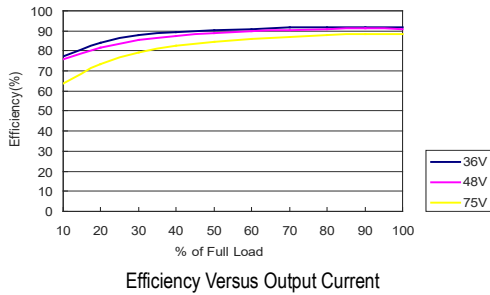

Typical Output Ripple and Noise
 $V_{in}=V_{in\ nom}$; Full Load

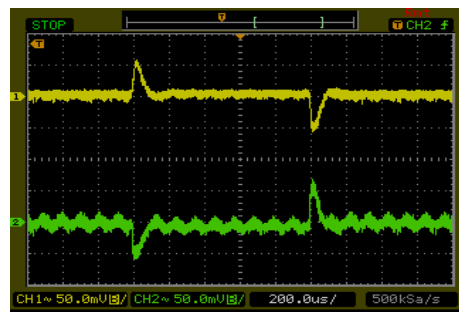

Transient Response to Dynamic Load Change
from 100% to 75% of Full Load; $V_{in}=V_{in\ nom}$

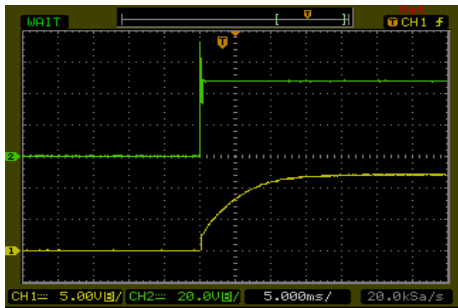

Typical Input Start-Up and Output Rise Characteristic
 $V_{in}=V_{in\ nom}$; Full Load

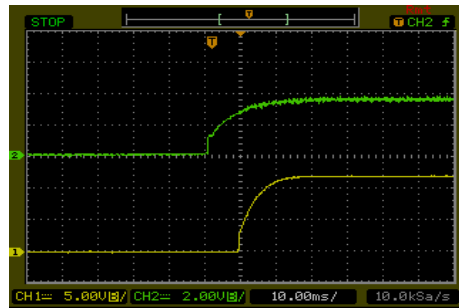

ON/OFF Voltage Start-Up and Output Rise Characteristic
 $V_{in}=V_{in\ nom}$; Full Load

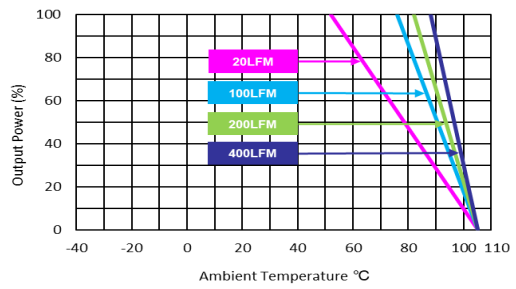
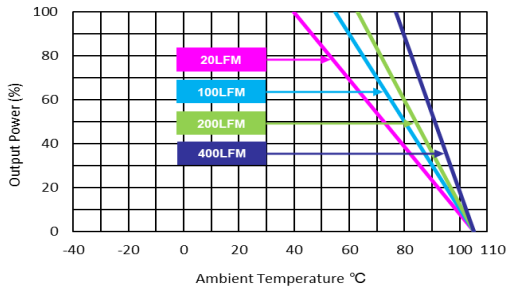

Characteristic Curves

All test conditions are at 25°C. The figures are identical for MKW40-48D15

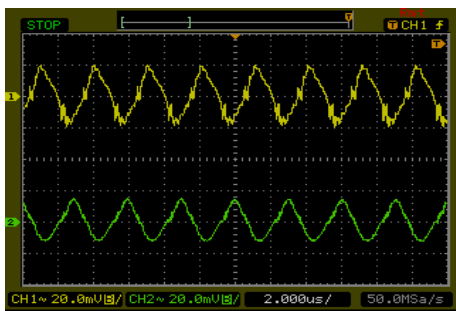
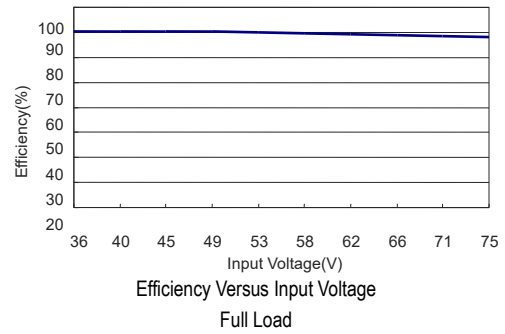
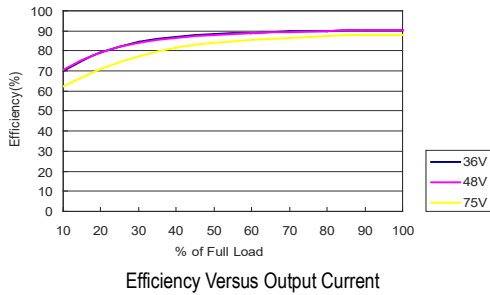

Typical Output Ripple and Noise
 $V_{in}=V_{in\ nom}$; Full Load

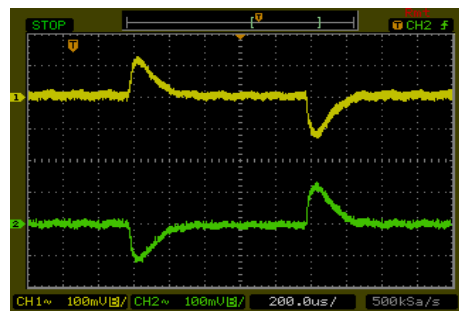

Transient Response to Dynamic Load Change
from 100% to 75% of Full Load; $V_{in}=V_{in\ nom}$

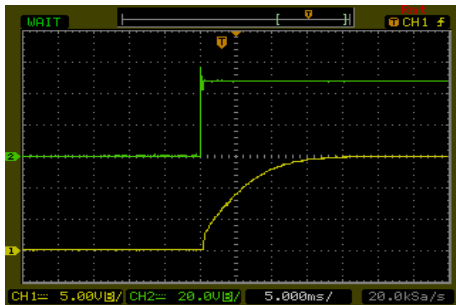

Typical Input Start-Up and Output Rise Characteristic
 $V_{in}=V_{in\ nom}$; Full Load

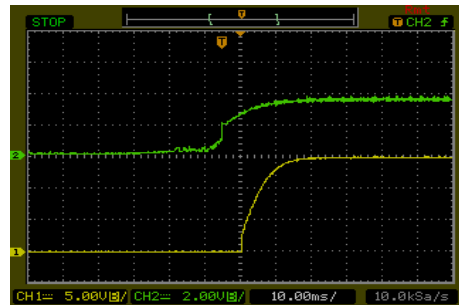

ON/OFF Voltage Start-Up and Output Rise Characteristic
 $V_{in}=V_{in\ nom}$; Full Load

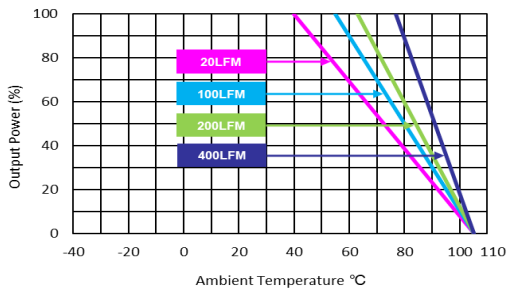

Derating Output Current Versus Ambient Temperature and Airflow
 $V_{in}=V_{in\ nom}$

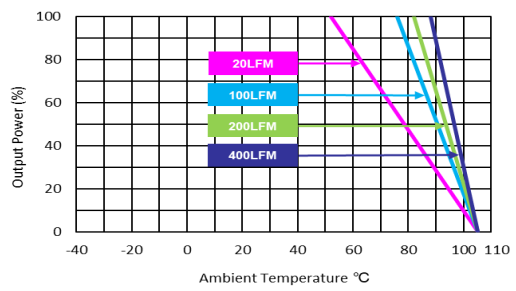

Derating Output Power Versus Ambient Temperature and Airflow
 $V_{in}=V_{in\ nom}$ (with Heatsink)

Package Specifications

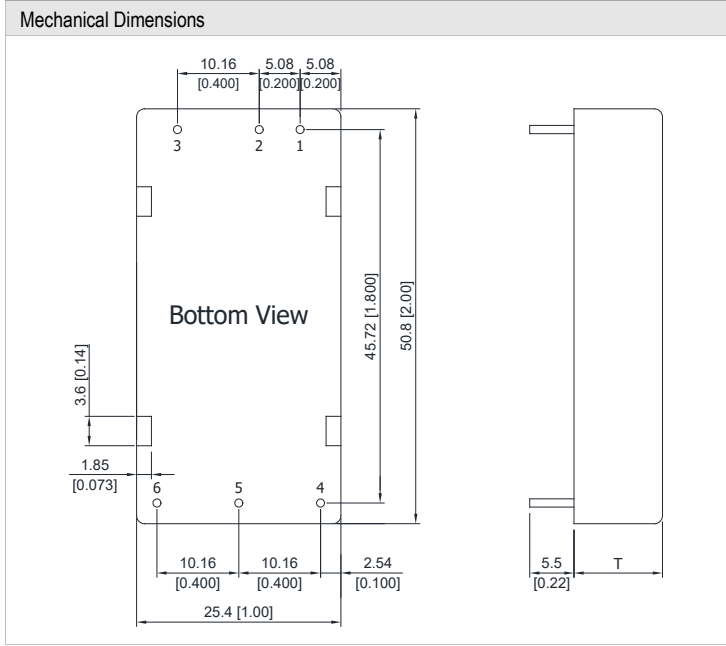

Pin Connections

Pin	Single Output	Dual Output	Diameter mm (inches)
1	+Vin	+Vin	∅ 1.0 [0.04]
2	-Vin	-Vin	∅ 1.0 [0.04]
3	Remote On/Off	Remote On/Off	∅ 1.0 [0.04]
4	+Vout	+Vout	∅ 1.0 [0.04]
5	-Vout	Common	∅ 1.0 [0.04]
6	Trim	-Vout	∅ 1.0 [0.04]

T: 11.0mm(0.43 inch) for 24V Output Models
 T: 10.2mm(0.40 inch) for Other Output Models

- ▶ All dimensions in mm (inches)
- ▶ Tolerance: X.X±0.25 (X.XX±0.01)
 X.XX±0.13 (X.XXX±0.005)
- ▶ Pin diameter tolerance: X.X±0.05 (X.XX±0.002)

Physical Characteristics

Case Size (24V Output)	: 50.8x25.4x11.0mm (2.0x1.0x0.43 inches)
Case Size (Other Output)	: 50.8x25.4x10.2mm (2.0x1.0x0.40 inches)
Case Material	: Metal With Non-Conductive Baseplate
Base Material	: FR4 PCB (flammability to UL 94V-0 rated)
Pin Material	: Copper Alloy
Weight	: 30g

Heatsink (Option -HS)

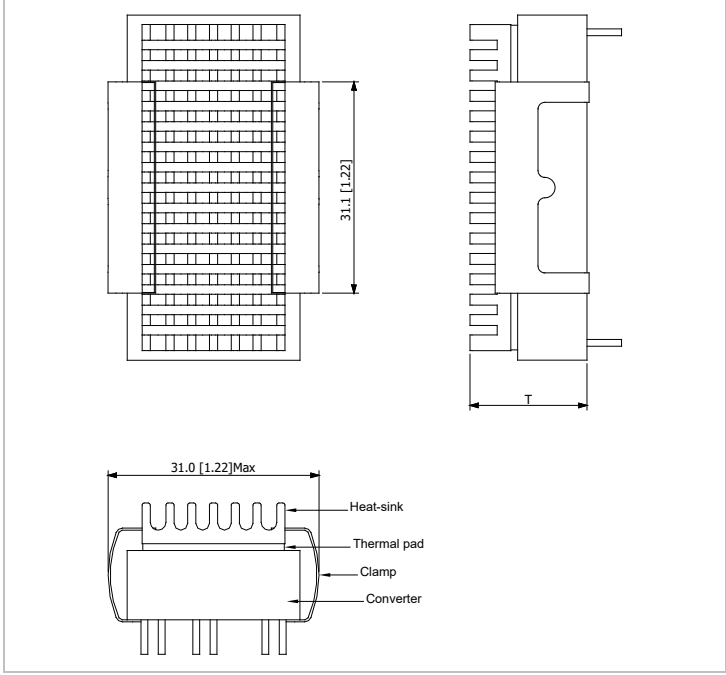

Physical Characteristics

Heatsink Material	: Aluminum
Finish	: Black Anodized Coating
Weight	: 9g

T: 18.0mm(0.71 inch) for 24V Output Models
 T: 17.2mm(0.68 inch) for Other Output Models

- ▶ The advantages of adding a heatsink are:
 1. To improve heat dissipation and increase the stability and reliability of the DC-DC converters at high operating temperatures.
 2. To increase operating temperature of the DC-DC converter, please refer to Derating Curve.

Recommended Pad Layout for Single & Dual Output Converter

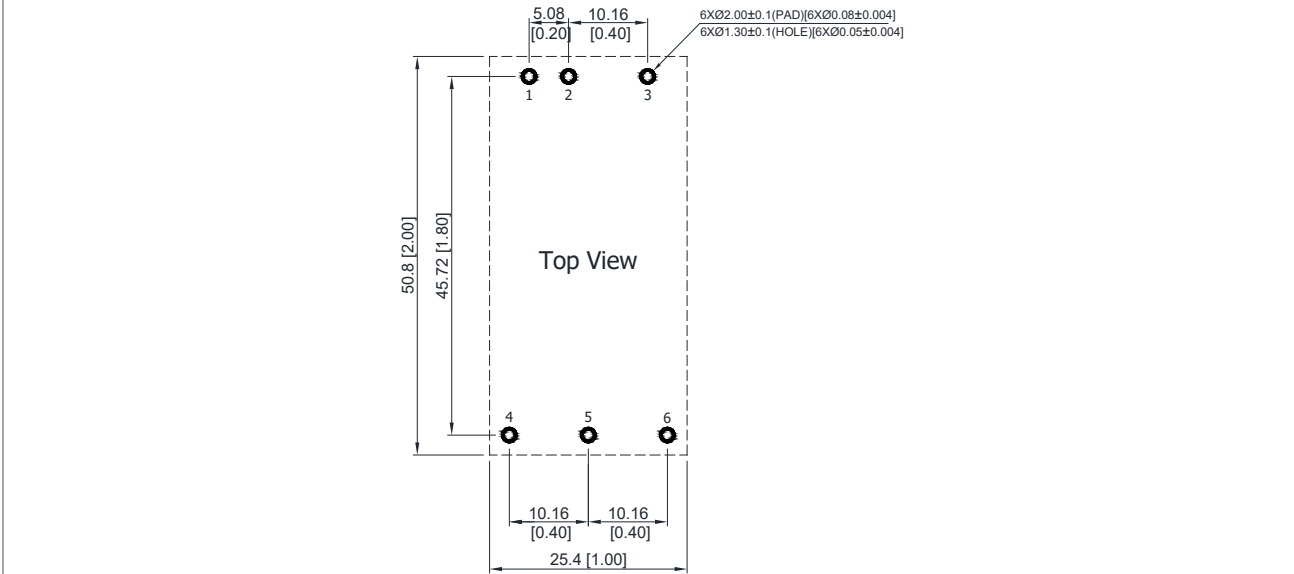

External Output Trimming

Output can be externally trimmed by using the method shown below

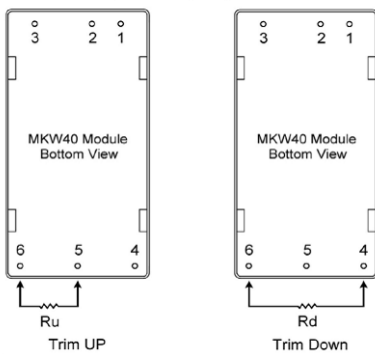

Trim Range (%)	MKW40-XXS033		MKW40-XXS05		MKW40-XXS12		MKW40-XXS15		MKW40-XXS24	
	Trim down (kΩ)	Trim up (kΩ)	Trim down (kΩ)	Trim up (kΩ)	Trim down (kΩ)	Trim up (kΩ)	Trim down (kΩ)	Trim up (kΩ)	Trim down (kΩ)	Trim up (kΩ)
1	72.61	60.84	138.88	106.87	413.55	351.00	530.73	422.77	333.39	---
2	32.55	27.40	62.41	47.76	184.55	157.50	238.61	189.89	148.80	243.70
3	19.20	16.25	36.92	28.06	108.22	93.00	141.24	112.26	87.26	---
4	12.52	10.68	24.18	18.21	70.05	60.75	92.56	73.44	56.50	108.50
5	8.51	7.34	16.53	12.30	47.15	41.40	63.35	50.15	38.04	---
6	5.84	5.11	11.44	8.36	31.88	28.50	43.87	34.63	25.73	63.43
7	3.94	3.51	7.79	5.55	20.98	19.29	29.96	23.54	16.94	---
8	2.51	2.32	5.06	3.44	12.80	12.37	19.53	15.22	10.35	40.90
9	1.39	1.39	2.94	1.79	6.44	7.00	11.41	8.75	5.22	---
10	0.50	0.65	1.24	0.48	1.35	2.70	4.92	3.58	1.12	27.38
12	---	---	---	---	---	---	---	---	---	18.37
14	---	---	---	---	---	---	---	---	---	11.93
16	---	---	---	---	---	---	---	---	---	7.10
18	---	---	---	---	---	---	---	---	---	3.34
20	---	---	---	---	---	---	---	---	---	0.34

Test Setup

Input Reflected-Ripple Current Test Setup

Input reflected-ripple current is measured with an inductor L_{in} (4.7 μ H) and C_{in} (220 μ F, ESR < 1.0 Ω at 100 kHz) to simulate source impedance. Capacitor C_{in} offsets possible battery impedance. Current ripple is measured at the input terminals of the module, measurement bandwidth is 0-500 kHz.

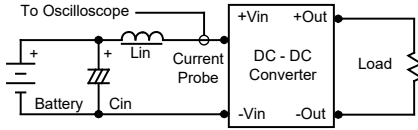

Peak-to-Peak Output Noise Measurement Test

Use a 1 μ F ceramic capacitor and a 10 μ F tantalum capacitor. Scope measurement should be made by using a BNC socket, measurement bandwidth is 0-20 MHz. Position the load between 50 mm and 75 mm from the DC-DC Converter.

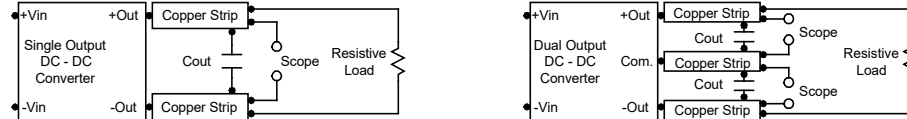

Technical Notes

Remote On/Off

Positive logic remote on/off turns the module on during a logic high voltage on the remote on/off pin, and off during a logic low. To turn the power module on and off, the user must supply a switch to control the voltage between the on/off terminal and the -Vin terminal. The switch can be an open collector or equivalent. A logic low is 0V to 1.2V. A logic high is 3.5V to 12V. The maximum sink current at the on/off terminal (Pin 3) during a logic low is -100 μ A.

Overcurrent Protection

To provide hiccup mode protection in a fault (output overload) condition, the unit is equipped with internal current limiting circuitry and can endure overload for an unlimited duration.

Overvoltage Protection

The output overvoltage clamp consists of control circuitry, which is independent of the primary regulation loop, that monitors the voltage on the output terminals. The control loop of the clamp has a higher voltage set point than the primary loop. This provides a redundant voltage control that reduces the risk of output overvoltage. The OVP level can be found in the output data.

Input Source Impedance

The power module should be connected to a low ac-impedance input source. Highly inductive source impedances can affect the stability of the power module. In applications where power is supplied over long lines and output loading is high, it may be necessary to use a capacitor at the input to ensure startup. Capacitor mounted close to the power module helps ensure stability of the unit, it is recommended to use a good quality low Equivalent Series Resistance (ESR < 1.0 Ω at 100 kHz) capacitor of a 33 μ F for the 12V input devices and a 10 μ F for the 24V and 48V devices.

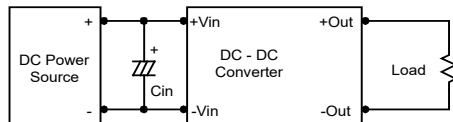

Output Ripple Reduction

A good quality low ESR capacitor placed as close as practicable across the load will give the best ripple and noise performance. To reduce output ripple, it is recommended to use 4.7 μ F capacitors at the output.

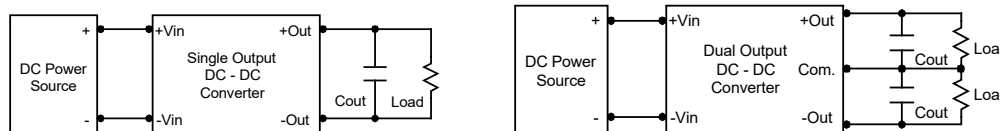

Maximum Capacitive Load

The MKW40 series has limitation of maximum connected capacitance at the output. The power module may be operated in current limiting mode during start-up, affecting the ramp-up and the startup time. The maximum capacitance can be found in the data sheet.

Thermal Considerations

Many conditions affect the thermal performance of the power module, such as orientation, airflow over the module and board spacing. To avoid exceeding the maximum temperature rating of the components inside the power module, the case temperature must be kept below 105 $^{\circ}$ C. The derating curves are determined from measurements obtained in a test setup.

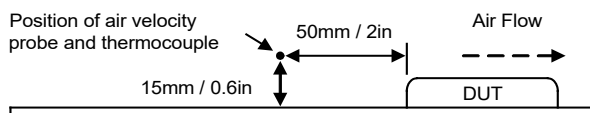

Remote ON/OFF Implementation

With no suffix, the positive logic remote ON/OFF control circuit is included.

Turns the module ON during logic High on the ON/Off pin and turns OFF during logic Low. The ON/OFF input signal (Von/off) that referenced to GND. If not using the remote on/off feature, please open circuit between on/off pin and -Vin pin to turn the module on.

With suffix-N, the negative logic remote ON/OFF control circuit is included.

Turns the module ON during logic Low on the On/Off pin and turns OFF during logic High. The On/Off pin is an open collector/drain logic input signal (Von/off) that referenced to GND. If not using the remote on/off feature. Please short circuit between on/off pin and -Vin pin to turn the module on.

Remote ON/OFF implementation

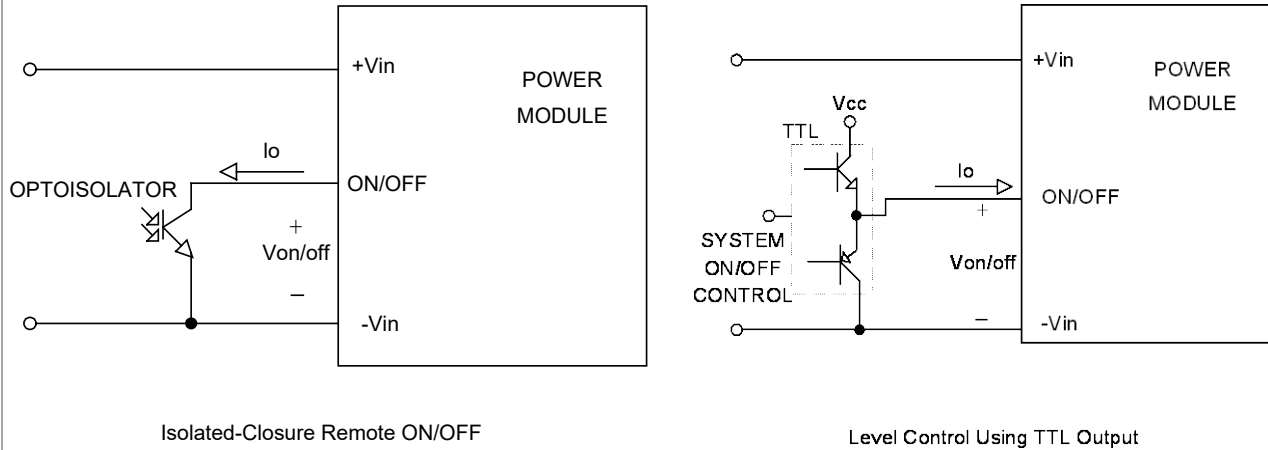

Packaging Information

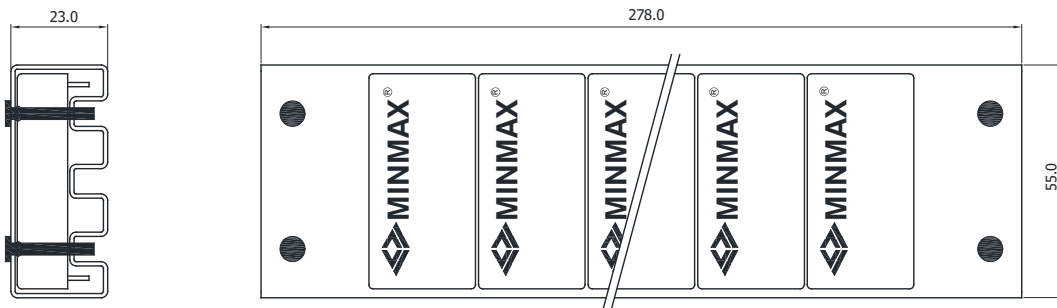

Unit: mm
10 PCS per TUBE

Wave Soldering Considerations

Lead free wave solder profile

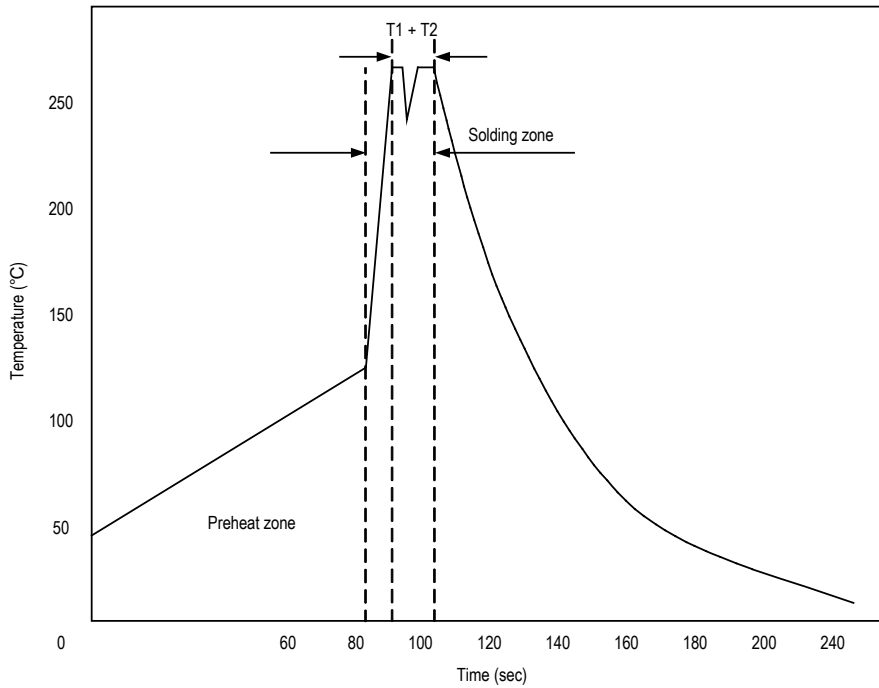

Zone	Reference Parameter
Preheat	Rise temp. speed : 3°C/sec max.
zone	Preheat temp. : 100~130°C
Actual	Peak temp. : 250~260°C
heating	Peak time(T1+T2) : 4~6 sec

Hand Welding Parameter

Reference Solder: Sn-Ag-Cu : Sn-Cu : Sn-Ag

Hand Welding: Soldering iron : Power 60W

Welding Time: 2~4 sec

Temp.: 380~400°C

Part Number Structure											
M	K	W	40	-	12	S	033				
Package Type 2" X 1"		Wide 2:1 Input Voltage Range		Output Power 40 Watt		Input Voltage Range		Output Quantity		Output Voltage	
						12: 9 ~ 18 VDC		S: Single		033: 3.3 VDC	
						24: 18 ~ 36 VDC		D: Dual		05: 5 VDC	
						48: 36 ~ 75 VDC				12: 12 VDC	
										15: 15 VDC	
										24: 24 VDC	

MTBF and Reliability		
The MTBF of MKW40 series of DC-DC converters has been calculated using MIL-HDBK 217F NOTICE2, Operating Temperature 25°C, Ground Benign.		
Model	MTBF	Unit
MKW40-12S033	243,300	Hours
MKW40-12S05	223,500	
MKW40-12S12	241,600	
MKW40-12S15	274,600	
MKW40-12S24	545,808	
MKW40-12D12	207,800	
MKW40-12D15	218,500	
MKW40-24S033	307,800	
MKW40-24S05	310,400	
MKW40-24S12	332,900	
MKW40-24S15	341,500	
MKW40-24S24	556,956	
MKW40-24D12	229,200	
MKW40-24D15	278,300	
MKW40-48S033	305,700	
MKW40-48S05	318,600	
MKW40-48S12	391,900	
MKW40-48S15	396,200	
MKW40-48S24	572,107	
MKW40-48D12	268,600	
MKW40-48D15	279,800	