



MINMAX[®]

MKWI40 Series

Electric Characteristic Note

MKWI40 Series EC Note

DC-DC CONVERTER 40W, Highest Power Density

Features

- ▶ Smallest Encapsulated 40W Converter
- ▶ Ultra-compact 2" X 1" Package
- ▶ Ultra-wide 4:1 Input Voltage Range
- ▶ Fully Regulated Output Voltage
- ▶ Excellent Efficiency up to 91%
- ▶ I/O Isolation 1500 VDC
- ▶ Operating Ambient Temp. Range -40°C to +80°C
- ▶ No Min. Load Requirement
- ▶ Overload/Voltage/Temp. and Short Circuit Protection
- ▶ Remote On/Off Control, Output Voltage Trim
- ▶ Shielded Metal Case with Insulated Baseplate
- ▶ UL/cUL/IEC/EN 62368-1(60950-1) Safety Approval & CE Marking

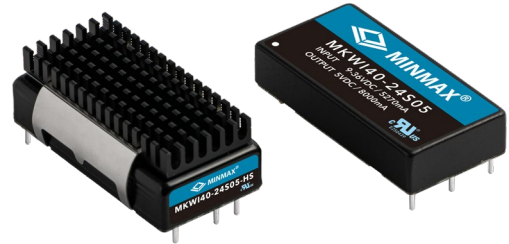

Applications

- ▶ Distributed power architectures
- ▶ Workstations
- ▶ Computer equipment
- ▶ Communications equipment

Product Overview

The MINMAX MKWI40 series is the latest generation of high performance DC-DC converter modules setting a new standard concerning power density. The product offers fully 40W in an encapsulated, shielded metal package with dimensions of just 2.0"x1.0"x0.4". All models provide ultra-wide 4:1 input voltage range and precisely regulated output voltages.

Advanced circuit topology provides a very high efficiency up to 91% which allows an operating temperature range of -40°C to +80°C. Further features include remote On/Off, trimmable output voltage, under-voltage lockout as well as overload and over-temperature protection. Typical applications for these converters are battery operated equipment, instrumentation, distributed power architectures in communication and industrial electronics and many other space critical applications.

Table of contents

Model Selection Guide	P2	External Output Trimming.....	P21
Input Specifications.....	P2	Test Setup.....	P22
Remote On/Off Control	P2	Technical Notes	P22
Output Specifications.....	P3	Remote ON/OFF Implementation.....	P23
General Specifications.....	P3	Packaging Information for Tube	P23
EMC Specifications.....	P3	Wave Soldering Considerations	P24
Environmental Specifications	P4	Hand Welding Parameter	P24
Characteristic Curves	P5	Part Number Structure	P25
Package Specifications	P19	MTBF and Reliability	P25
Recommended Pad Layout for Single & Dual Output Converter.....	P19		

Model Selection Guide

Model Number	Input Voltage (Range)	Output Voltage	Output Current		Input Current		Reflected Ripple Current	Over Voltage Protection	Max. capacitive Load	Efficiency (typ.)
			Max.	Min.	@Max. Load	@No Load				@Max. Load
	VDC	VDC	mA	mA	mA(typ.)	mA(typ.)	mA (typ.)	VDC	μF	%
MKWI40-24S033	24 (9 ~ 36)	3.3	8000	0	1240	90	30	3.9	21000	89
MKWI40-24S05		5	8000	0	1850	90		6.2	13600	90
MKWI40-24S12		12	3330	0	1870	95		15	2400	89
MKWI40-24S15		15	2670	0	1870	105		18	1500	89
MKWI40-24S24		24	1670	0	1835	115		30	600	91
MKWI40-24D12		±12	±1670	±145	1890	65		±15	1200#	88
MKWI40-24D15		±15	±1330	±110	1890	65		±18	750#	88
MKWI40-48S033	48 (18 ~ 75)	3.3	8000	0	620	55	20	3.9	21000	89
MKWI40-48S05		5	8000	0	930	55		6.2	13600	90
MKWI40-48S12		12	3330	0	930	60		15	2400	90
MKWI40-48S15		15	2670	0	930	65		18	1500	90
MKWI40-48S24		24	1670	0	918	75		30	600	91
MKWI40-48D12		±12	±1670	±145	950	45		±15	1200#	88
MKWI40-48D15		±15	±1330	±110	950	45		±18	750#	88

For each output

Input Specifications

Parameter	Conditions / Model	Min.	Typ.	Max.	Unit
Input Surge Voltage (100ms. max.)	24V Input Models	-0.7	---	50	VDC
	48V Input Models	-0.7	---	100	
Start-Up Threshold Voltage	24V Input Models	---	---	9	
	48V Input Models	---	---	18	
Under Voltage Lockout	24V Input Models	---	8.3	---	
	48V Input Models	---	16.5	---	
Start Up Time (Power On)	Nominal Vin and Constant Resistive Load	---	---	30	ms
Input Filter	All Models	Internal LC Type			

Remote On/Off Control

Parameter	Conditions	Min.	Typ.	Max.	Unit
Converter On	3.5V ~ 12V or Open Circuit				
Converter Off	0V ~ 1.2V or Short Circuit				
Control Input Current (on)	Vctrl = 5.0V	---	0.5	---	mA
Control Input Current (off)	Vctrl = 0V	---	-0.5	---	mA
Control Common	Referenced to Negative Input				
Standby Input Current	Nominal Vin	---	2.5	---	mA

Output Specifications						
Parameter	Conditions / Model		Min.	Typ.	Max.	Unit
Output Voltage Setting Accuracy			---	---	±1.0	%Vnom.
Output Voltage Balance	Dual Output, Balanced Loads		---	---	±2.0	%
Line Regulation	Vin=Min. to Max. @Full Load		---	---	±0.5	%
Load Regulation	Min. Load to Full Load	Single Output	---	---	±0.5	%
		Dual Output	---	---	±1.0	%
Load Cross Regulation (Dual Output)	Asymmetrical Load 25%/100% Full Load		---	---	±5.0	%
Minimum Load	No Minimum Load Requirement for Single Output Models, for dual Output Models see Table					
Ripple & Noise	0-20 MHz Bandwidth	3.3V & 5V Models	---	---	100	mV _{P-P}
		12V, 15V & 24V Models	---	---	150	mV _{P-P}
		Dual Output Models	---	---	150	mV _{P-P}
Transient Recovery Time	25% Load Step Change		---	250	---	μsec
Transient Response Deviation			---	±3	±5	%
Temperature Coefficient			---	---	±0.02	%/°C
Trim Up / Down Range (See Page 21)	% of Nominal Output Voltage	24Vo Models	---	---	+20 / -10	%
		Other Models	---	---	±10	
Over Load Protection	Current Limitation at 150% typ. of Iout max., Hiccup					
Short Circuit Protection	24Vo Models		Continuous, Automatic Recovery (Hiccup Mode 0.3Hz typ.)			
	Other Models		Continuous, Automatic Recovery (Hiccup Mode 1.5Hz typ.)			

General Specifications						
Parameter	Conditions / Model		Min.	Typ.	Max.	Unit
I/O Isolation Voltage	60 Seconds		1500	---	---	VDC
	1 Seconds		1800	---	---	VDC
I/O Isolation Resistance	500 VDC		1000	---	---	MΩ
I/O Isolation Capacitance	100kHz, 1V		---	---	1500	pF
Switching Frequency	24Vo Models		---	285	---	kHz
	Other Models		---	320	---	kHz
MTBF(calculated)	MIL-HDBK-217F@25°C, Ground Benign		328,000			Hours
Safety Approvals	UL/cUL 60950-1 recognition(CSA certificate), IEC/EN 60950-1(CB-report)					
	UL/cUL 62368-1 recognition(UL certificate), IEC/EN 62368-1(CB-report)					

EMC Specifications				
Parameter	Standards & Level			Performance
EMI _(s)	Conduction	EN55032	With external components	Class A
	Radiation			
EMS _(s)	EN 55035			
	ESD	EN61000-4-2 air ± 8kV , Contact ± 6kV		A
	Radiated immunity	EN61000-4-3 10V/m		A
	Fast transient	EN61000-4-4 ±2kV		A
	Surge	EN61000-4-5 ±1kV		A
	Conducted immunity	EN61000-4-6 10Vrms		A
	PFMF	EN61000-4-8 3A/m		A

Environmental Specifications					
Parameter	Conditions / Model	Min.	Max.		Unit
			without Heatsink	with Heatsink	
Operating Ambient Temperature Range Nominal Vin, Load 100% Inom. (for Power Derating see relative Derating Curves)	MKWI40-XXS033	-40	66	73	°C
	MKWI40-24S05, MKWI40-48S05		51	61	
	MKWI40-48S12, MKWI40-48S15				
	MKWI40-24S12, MKWI40-24S15		45	57	
	MKWI40-24S24, MKWI40-48S24		57	66	
	MKWI40-24D12, MKWI40-24D15		40	52	
	MKWI40-48D12, MKWI40-48D15				
Thermal Impedance	20LFM Convection without Heatsink	12.0	---	---	°C/W
	20LFM Convection with Heatsink	10.0	---	---	°C/W
	100LFM Convection without Heatsink	9.0	---	---	°C/W
	100LFM Convection with Heatsink	5.4	---	---	°C/W
	200LFM Convection without Heatsink	8.0	---	---	°C/W
	200LFM Convection with Heatsink	4.5	---	---	°C/W
	400LFM Convection without Heatsink	6.0	---	---	°C/W
	400LFM Convection with Heatsink	3.0	---	---	°C/W
Case Temperature		---	+105		°C
Thermal Protection	Shutdown Temperature		110°C typ.		
Storage Temperature Range		-50	+125		°C
Humidity (non condensing)		---	95		% rel. H
RFI	Six-Sided Shielded, Metal Case				
Lead Temperature (1.5mm from case for 10Sec.)		---	260		°C

Notes

- Specifications typical at Ta=+25°C, resistive load, nominal input voltage and rated output current unless otherwise noted.
- Transient recovery time is measured to within 1% error band for a step change in output load of 75% to 100%.
- Ripple & Noise measurement with a 1µF/50V M/C and a 10µF50V T/C.
- We recommend to protect the converter by a slow blow fuse in the input supply line.
- Other input and output voltage may be available, please contact MINMAX.
- The external components might be required to meet EMI/EMS standard for some of test items. Please contact MINMAX for the solution in detail.
- Do not exceed maximum power specification when adjusting output voltage.
- Specifications are subject to change without notice.
- The repeated high voltage isolation testing of the converter can degrade isolation capability, to a lesser or greater degree depending on materials, construction, environment and reflow solder process. Any material is susceptible to eventual chemical degradation when subject to very high applied voltages thus implying that the number of tests should be strictly limited. We therefore strongly advise against repeated high voltage isolation testing, but if it is absolutely required, that the voltage be reduced by 20% from specified test voltage. Furthermore, the high voltage isolation capability after reflow solder process should be evaluated as it is applied on system.

Characteristic Curves

All test conditions are at 25°C The figures are identical for MKWI40-24S033

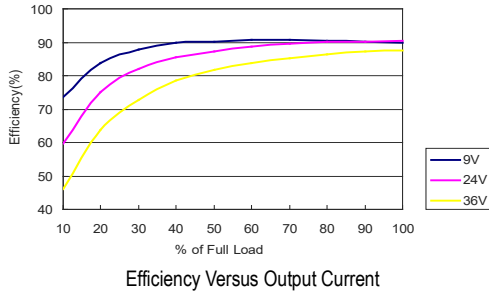

Efficiency Versus Output Current

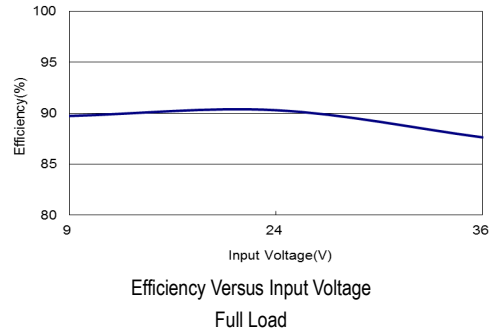

Efficiency Versus Input Voltage Full Load

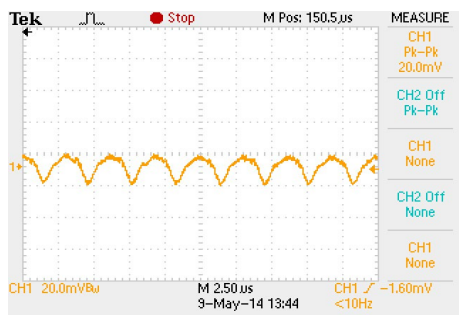

Typical Output Ripple and Noise
 $V_{in}=V_{in nom}$; Full Load

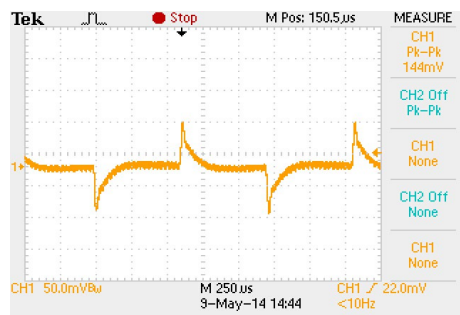

Transient Response to Dynamic Load Change
from 100% to 75% of Full Load ; $V_{in}=V_{in nom}$

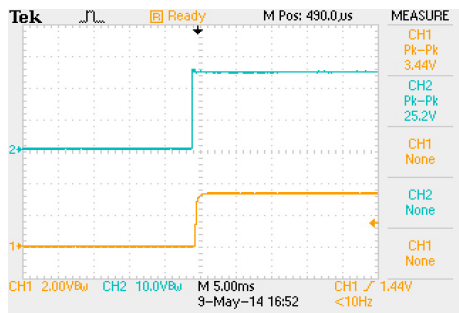

Typical Input Start-Up and Output Rise Characteristic
 $V_{in}=V_{in nom}$; Full Load

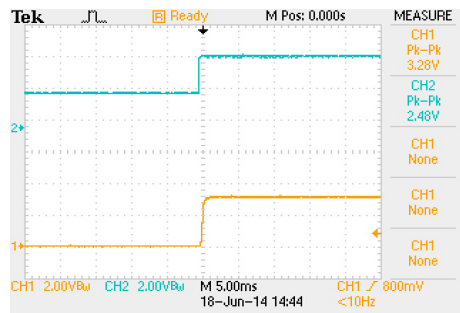

ON/OFF Voltage Start-Up and Output Rise Characteristic
 $V_{in}=V_{in nom}$; Full Load

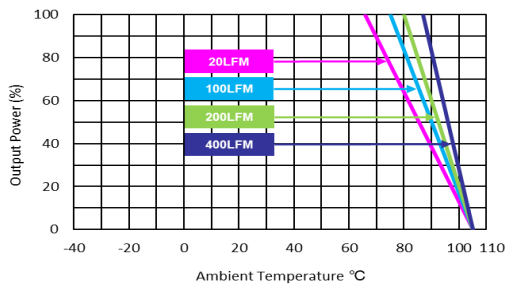

Derating Output Current Versus Ambient Temperature
 $V_{in}=V_{in nom}$

Characteristic Curves

All test conditions are at 25°C The figures are identical for MKWI40-24S05

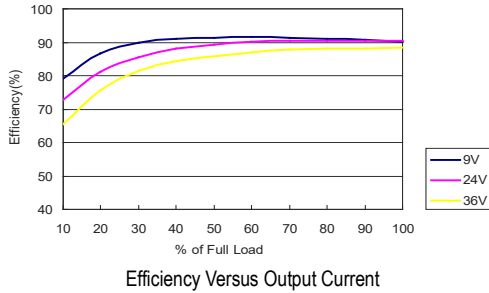

Efficiency Versus Output Current

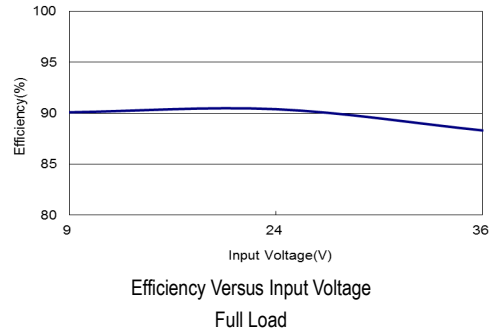

Efficiency Versus Input Voltage Full Load

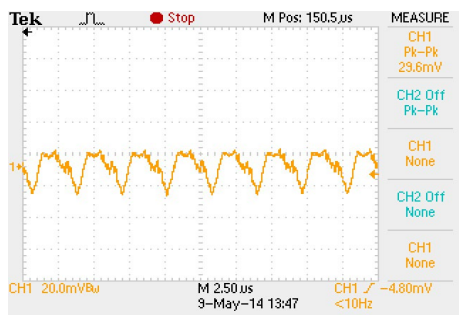

Typical Output Ripple and Noise
 $V_{in}=V_{in\ nom}$; Full Load

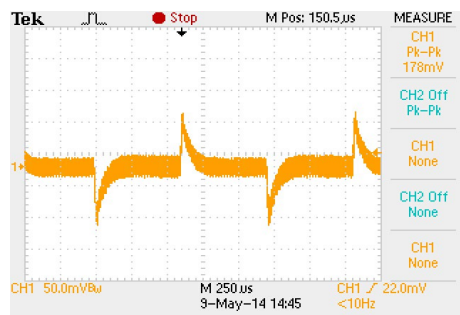

Transient Response to Dynamic Load Change
from 100% to 75% of Full Load ; $V_{in}=V_{in\ nom}$

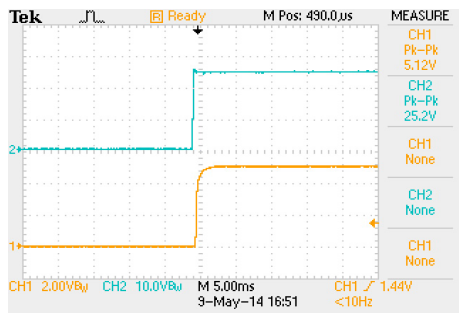

Typical Input Start-Up and Output Rise Characteristic
 $V_{in}=V_{in\ nom}$; Full Load

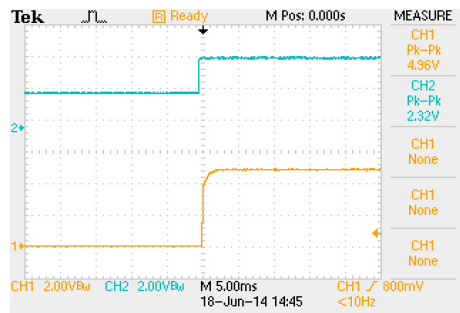

ON/OFF Voltage Start-Up and Output Rise Characteristic
 $V_{in}=V_{in\ nom}$; Full Load

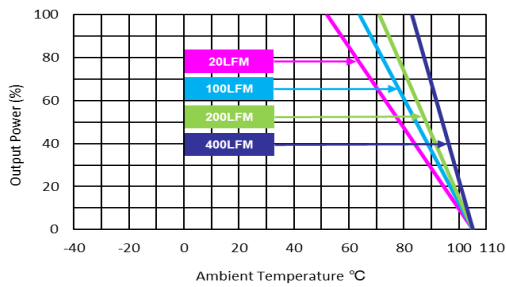

Derating Output Current Versus Ambient Temperature
 $V_{in}=V_{in\ nom}$

Characteristic Curves

All test conditions are at 25°C The figures are identical for MKWI40-24S12

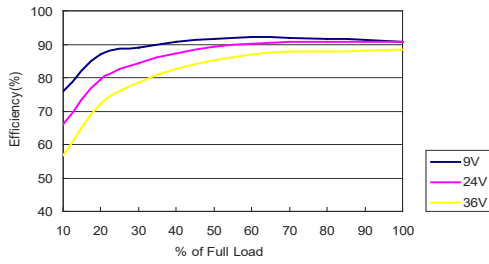

Efficiency Versus Output Current

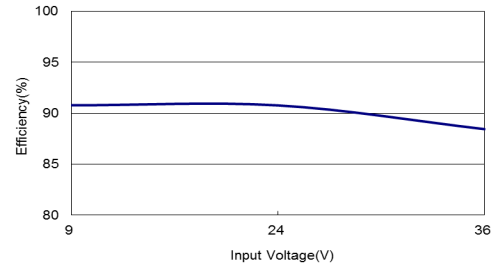

Efficiency Versus Input Voltage Full Load

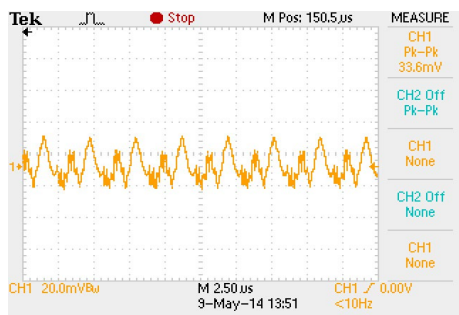

Typical Output Ripple and Noise
 $V_{in}=V_{in\ nom}$; Full Load

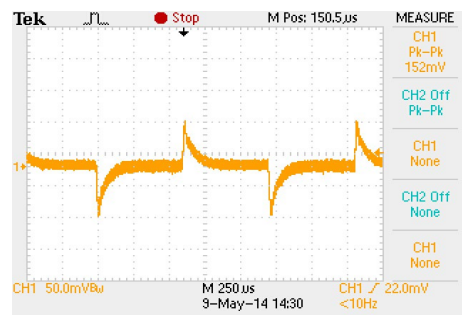

Transient Response to Dynamic Load Change
from 100% to 75% of Full Load ; $V_{in}=V_{in\ nom}$

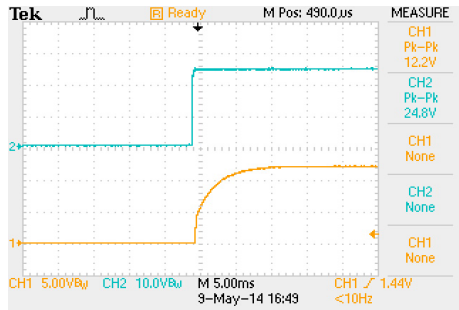

Typical Input Start-Up and Output Rise Characteristic
 $V_{in}=V_{in\ nom}$; Full Load

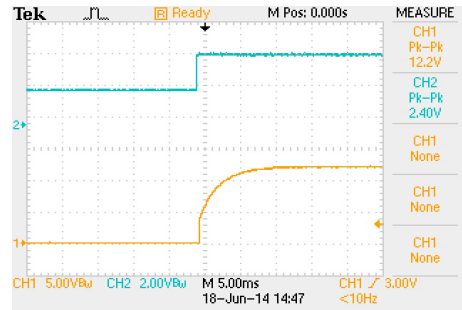

ON/OFF Voltage Start-Up and Output Rise Characteristic
 $V_{in}=V_{in\ nom}$; Full Load

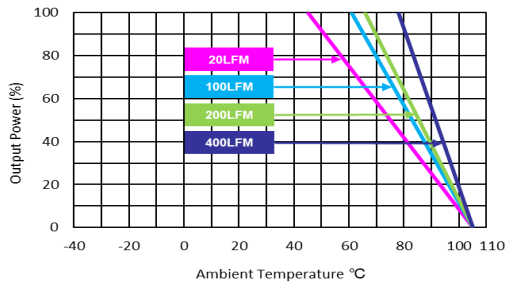

Derating Output Current Versus Ambient Temperature
 $V_{in}=V_{in\ nom}$

Characteristic Curves

All test conditions are at 25°C The figures are identical for MKWI40-24S15

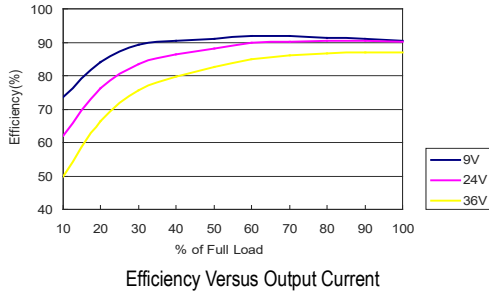

Efficiency Versus Output Current

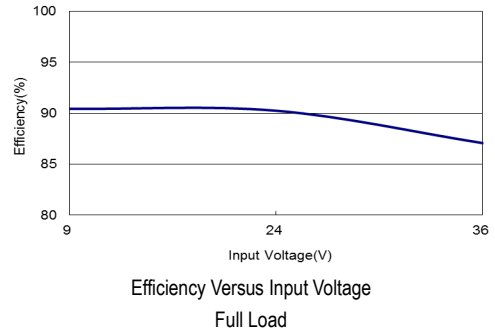

Efficiency Versus Input Voltage Full Load

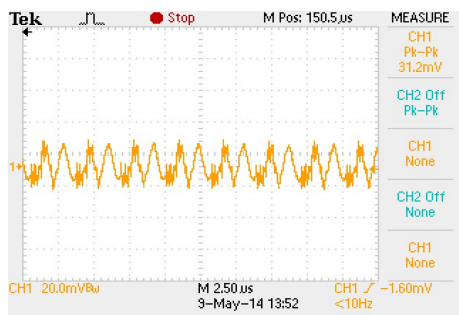

Typical Output Ripple and Noise
 $V_{in}=V_{in\ nom}$; Full Load

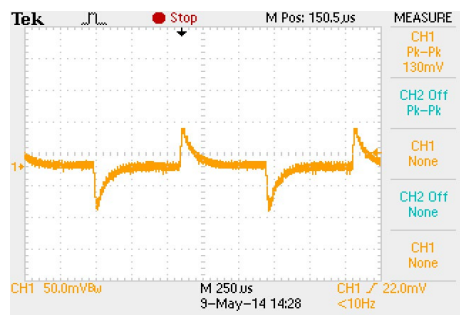

Transient Response to Dynamic Load Change
from 100% to 75% of Full Load ; $V_{in}=V_{in\ nom}$

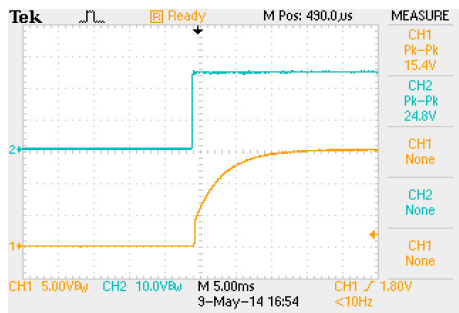

Typical Input Start-up and Output Rise Characteristic
 $V_{in}=V_{in\ nom}$; Full Load

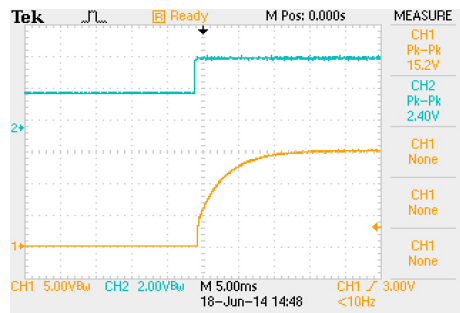

ON/OFF Voltage Start-up and Output Rise Characteristic
 $V_{in}=V_{in\ nom}$; Full Load

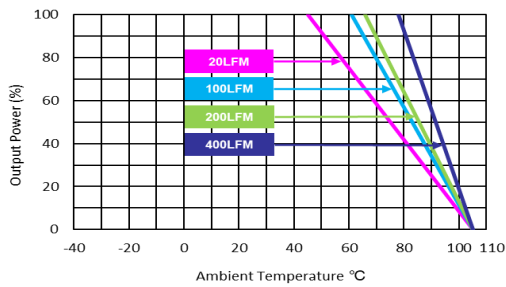

Derating Output Current Versus Ambient Temperature
 $V_{in}=V_{in\ nom}$

Characteristic Curves

All test conditions are at 25°C The figures are identical for MKWI40-24S24

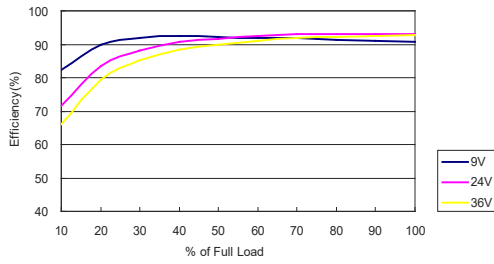

Efficiency Versus Output Current

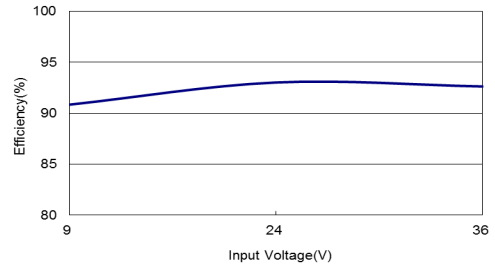

Efficiency Versus Input Voltage Full Load

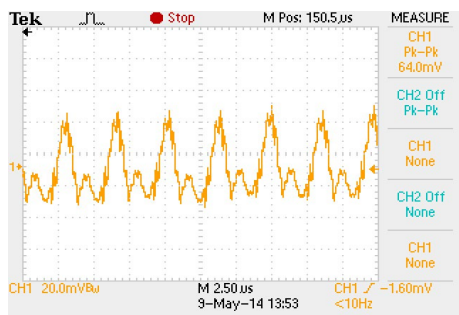

Typical Output Ripple and Noise
 $V_{in}=V_{in nom}$; Full Load

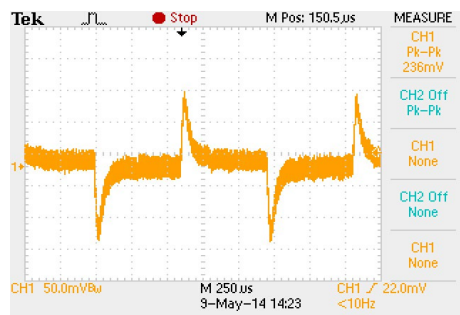

Transient Response to Dynamic Load Change
from 100% to 75% of Full Load ; $V_{in}=V_{in nom}$

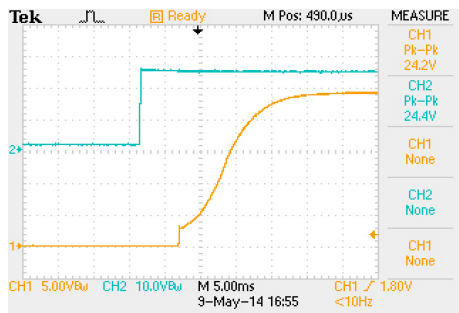

Typical Input Start-Up and Output Rise Characteristic
 $V_{in}=V_{in nom}$; Full Load

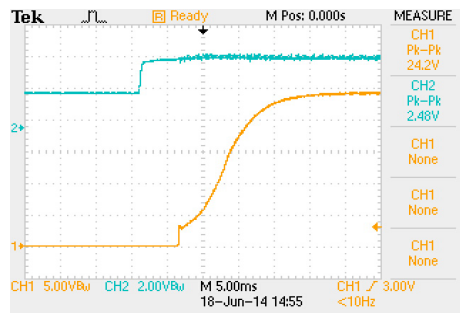

ON/OFF Voltage Start-Up and Output Rise Characteristic
 $V_{in}=V_{in nom}$; Full Load

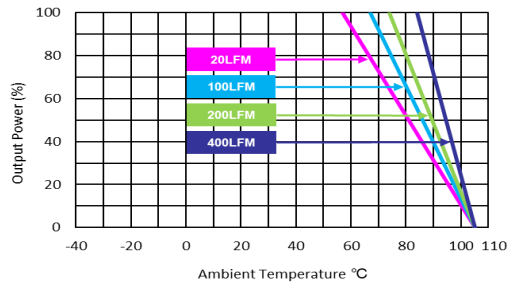

Derating Output Current Versus Ambient Temperature
 $V_{in}=V_{in nom}$

Characteristic Curves

All test conditions are at 25°C The figures are identical for MKWI40-24D12

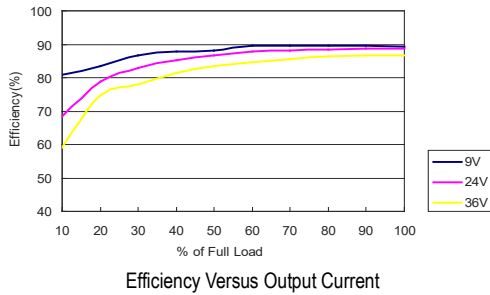

Efficiency Versus Output Current

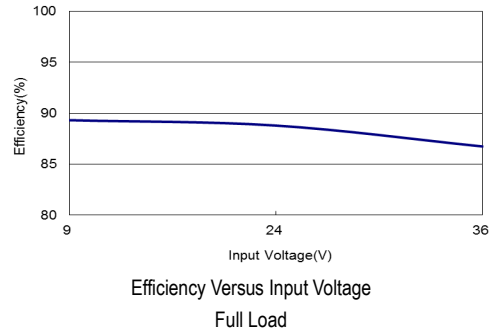

Efficiency Versus Input Voltage Full Load

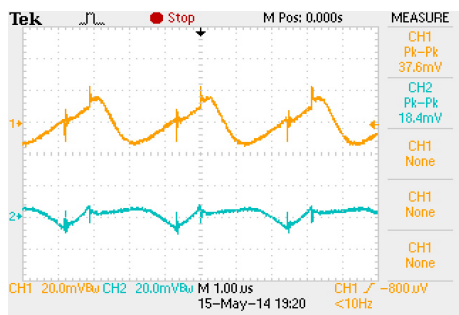

Typical Output Ripple and Noise
 $V_{in}=V_{in nom}$; Full Load

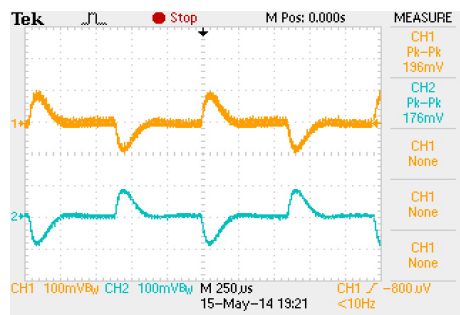

Transient Response to Dynamic Load Change
from 100% to 75% of Full Load ; $V_{in}=V_{in nom}$

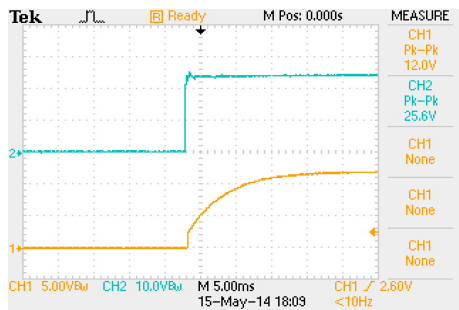

Typical Input Start-Up and Output Rise Characteristic
 $V_{in}=V_{in nom}$; Full Load

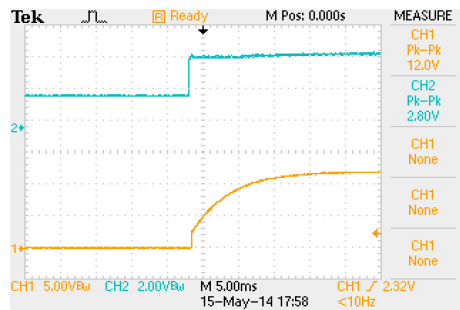

ON/OFF Voltage Start-Up and Output Rise Characteristic
 $V_{in}=V_{in nom}$; Full Load

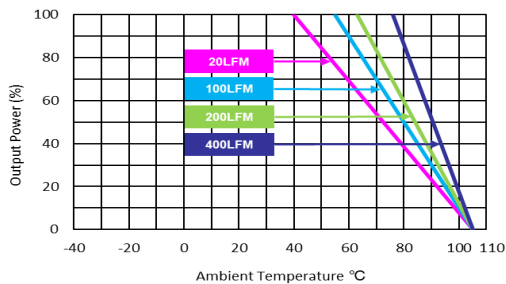

Derating Output Current Versus Ambient Temperature
 $V_{in}=V_{in nom}$

Characteristic Curves

All test conditions are at 25°C The figures are identical for MKWI40-24D15

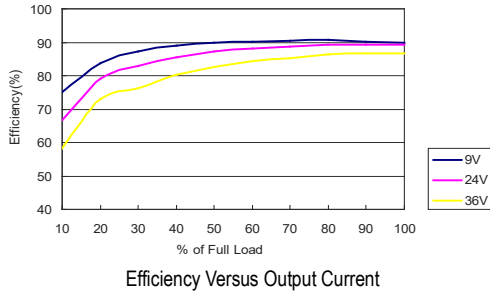

Efficiency Versus Output Current

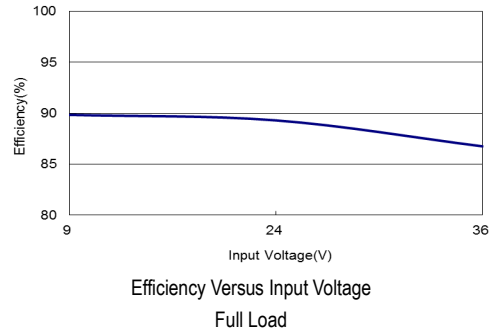

Efficiency Versus Input Voltage Full Load

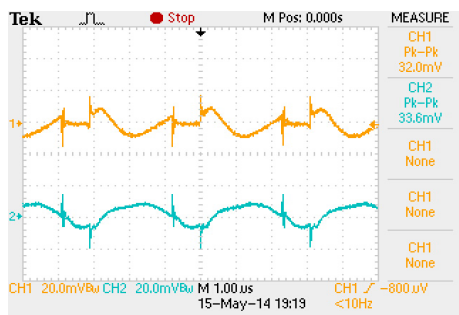

Typical Output Ripple and Noise
 $V_{in}=V_{in nom}$; Full Load

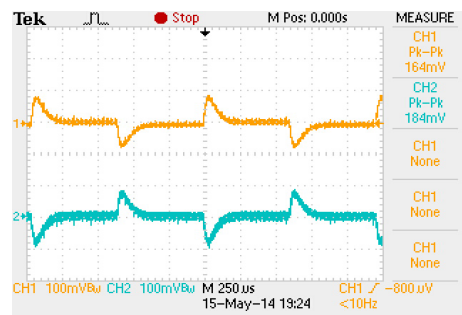

Transient Response to Dynamic Load Change
from 100% to 75% of Full Load ; $V_{in}=V_{in nom}$

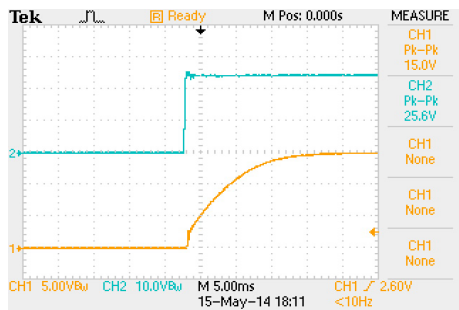

Typical Input Start-up and Output Rise Characteristic
 $V_{in}=V_{in nom}$; Full Load

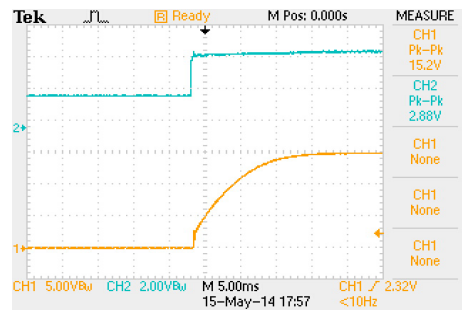

ON/OFF Voltage Start-up and Output Rise Characteristic
 $V_{in}=V_{in nom}$; Full Load

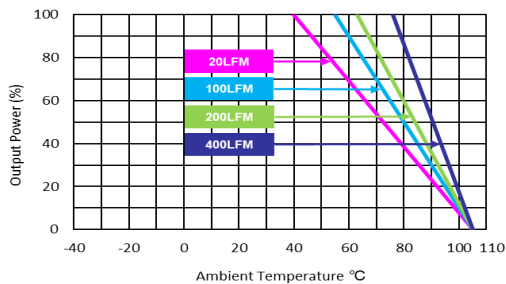

Derating Output Current Versus Ambient Temperature
 $V_{in}=V_{in nom}$

Characteristic Curves

All test conditions are at 25°C. The figures are identical for MKWI40-48S033

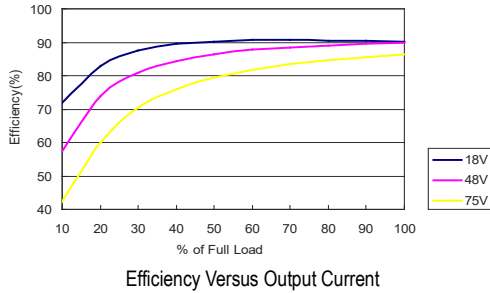

Efficiency Versus Output Current

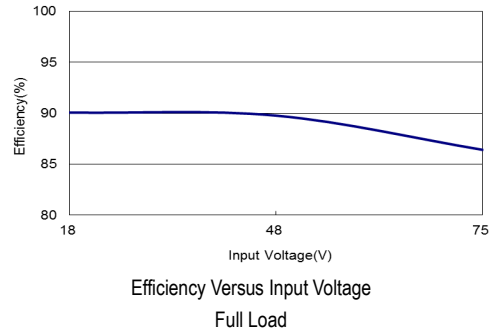

Efficiency Versus Input Voltage Full Load

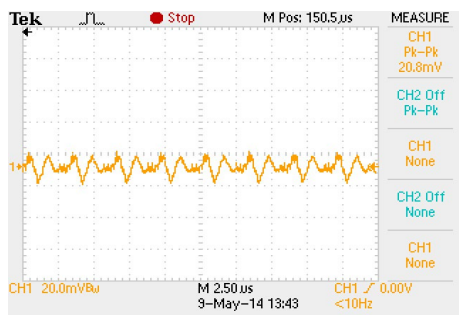

Typical Output Ripple and Noise
 $V_{in}=V_{in nom}$; Full Load

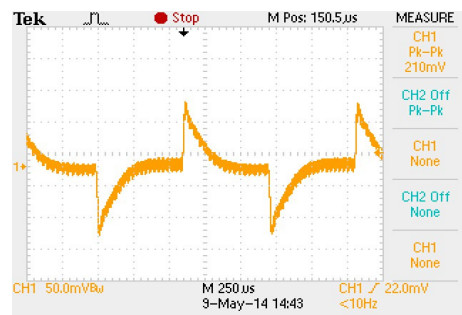

Transient Response to Dynamic Load Change
from 100% to 75% of Full Load ; $V_{in}=V_{in nom}$

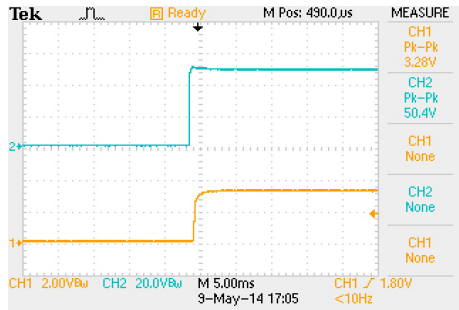

Typical Input Start-Up and Output Rise Characteristic
 $V_{in}=V_{in nom}$; Full Load

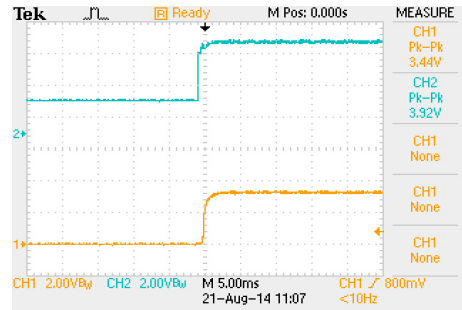

ON/OFF Voltage Start-Up and Output Rise Characteristic
 $V_{in}=V_{in nom}$; Full Load

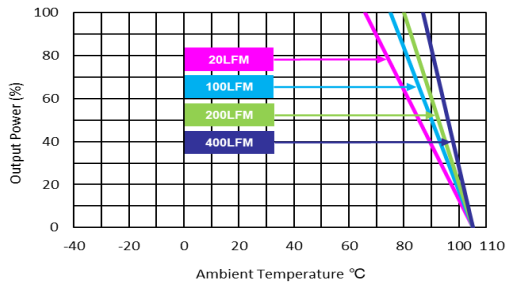

Derating Output Current Versus Ambient Temperature
 $V_{in}=V_{in nom}$

Characteristic Curves

All test conditions are at 25°C. The figures are identical for MKWI40-48S05

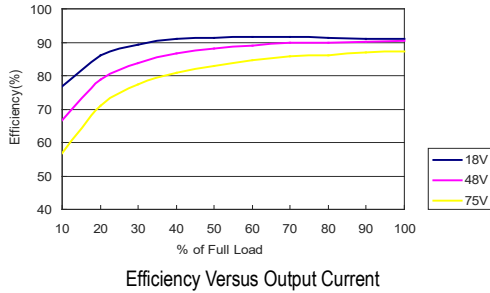

Efficiency Versus Output Current

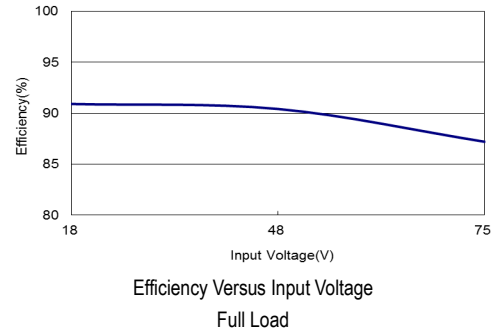

Efficiency Versus Input Voltage
Full Load

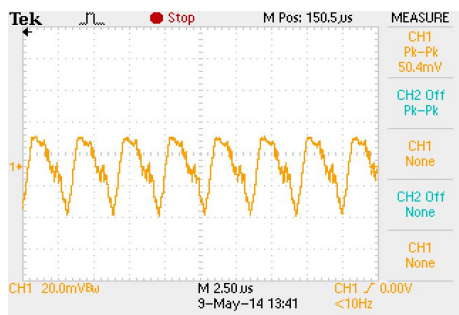

Typical Output Ripple and Noise
 $V_{in}=V_{in nom}$; Full Load

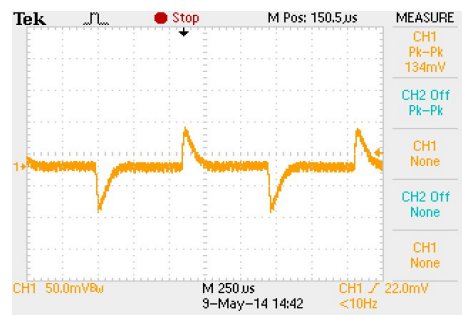

Transient Response to Dynamic Load Change
from 100% to 75% of Full Load ; $V_{in}=V_{in nom}$

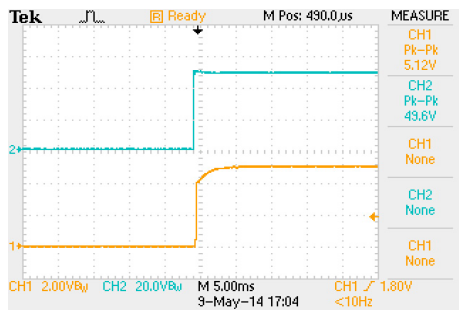

Typical Input Start-Up and Output Rise Characteristic
 $V_{in}=V_{in nom}$; Full Load

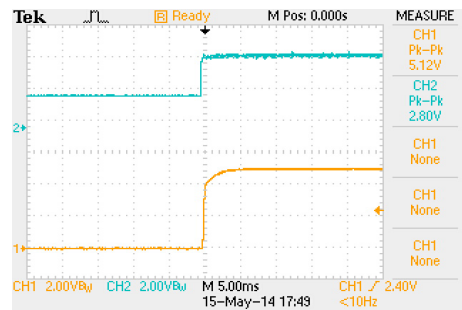

ON/OFF Voltage Start-Up and Output Rise Characteristic
 $V_{in}=V_{in nom}$; Full Load

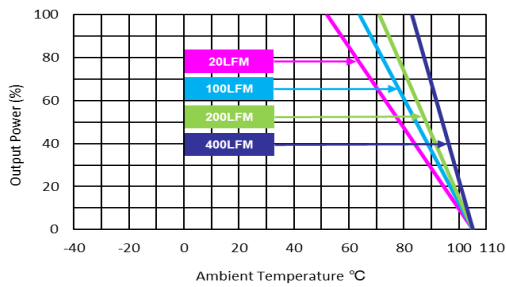

Derating Output Current Versus Ambient Temperature
 $V_{in}=V_{in nom}$

Characteristic Curves

All test conditions are at 25°C The figures are identical for MKWI40-48S12

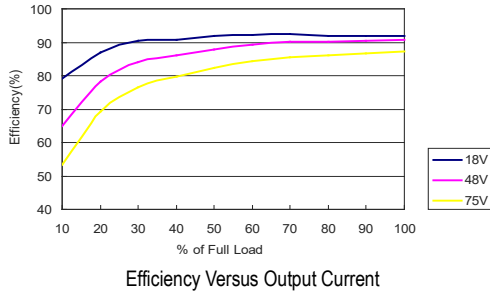

Efficiency Versus Output Current

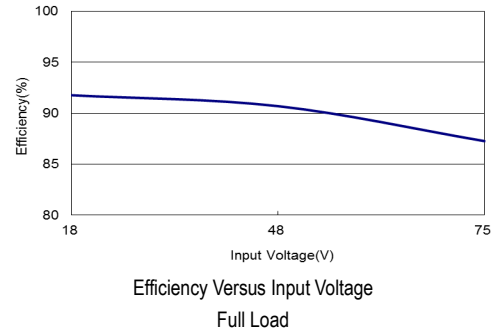

Efficiency Versus Input Voltage Full Load

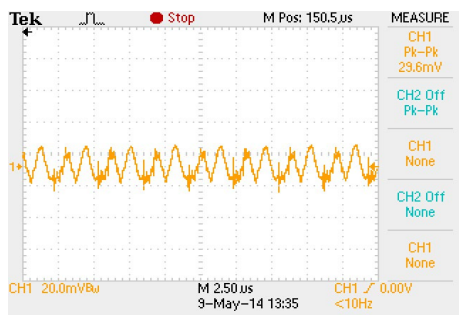

Typical Output Ripple and Noise
 $V_{in}=V_{in\ nom}$; Full Load

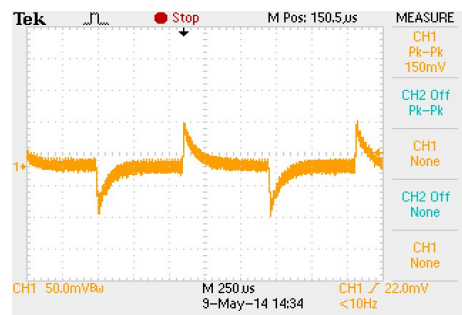

Transient Response to Dynamic Load Change
from 100% to 75% of Full Load ; $V_{in}=V_{in\ nom}$

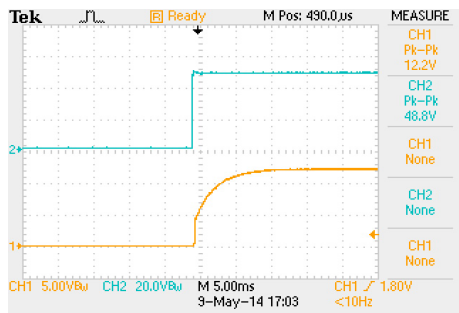

Typical Input Start-Up and Output Rise Characteristic
 $V_{in}=V_{in\ nom}$; Full Load

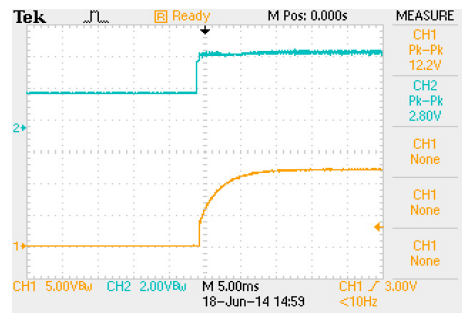

ON/OFF Voltage Start-Up and Output Rise Characteristic
 $V_{in}=V_{in\ nom}$; Full Load

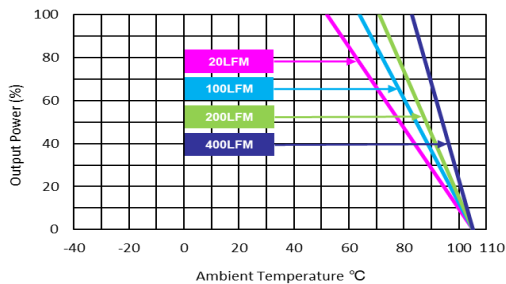

Derating Output Current Versus Ambient Temperature
 $V_{in}=V_{in\ nom}$

Characteristic Curves

All test conditions are at 25°C. The figures are identical for MKWI40-48S15

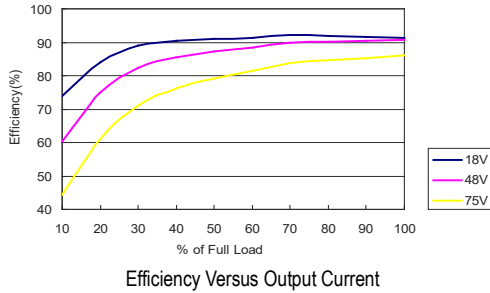

Efficiency Versus Output Current

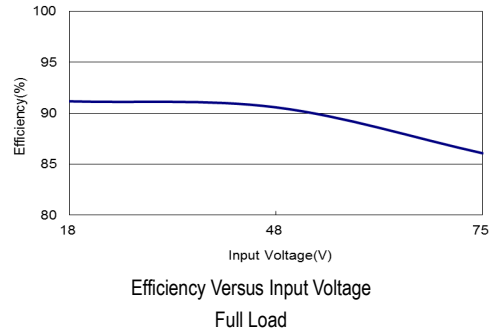

Efficiency Versus Input Voltage Full Load

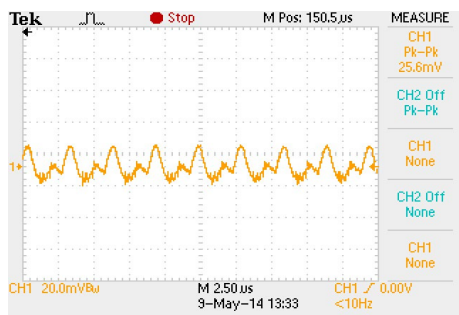

Typical Output Ripple and Noise
 $V_{in}=V_{in nom}$; Full Load

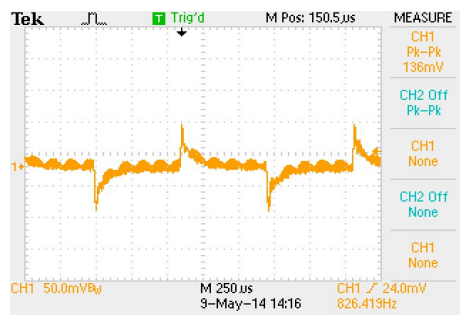

Transient Response to Dynamic Load Change
from 100% to 75% of Full Load ; $V_{in}=V_{in nom}$

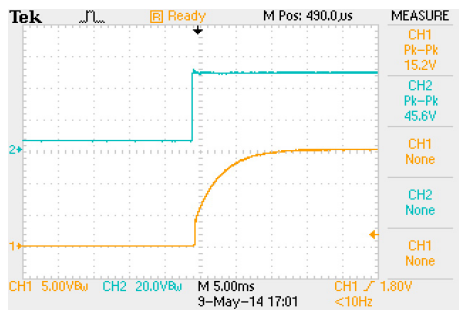

Typical Input Start-Up and Output Rise Characteristic
 $V_{in}=V_{in nom}$; Full Load

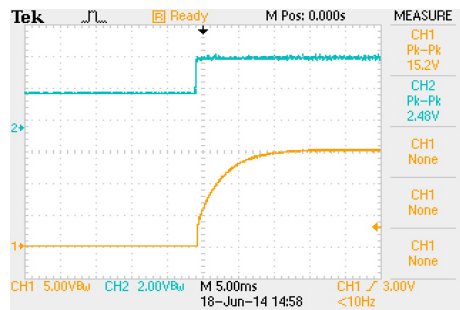

ON/OFF Voltage Start-Up and Output Rise Characteristic
 $V_{in}=V_{in nom}$; Full Load

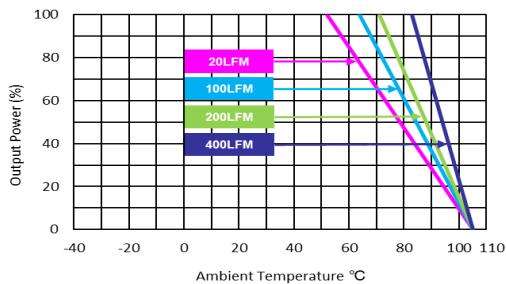

Derating Output Current Versus Ambient Temperature
 $V_{in}=V_{in nom}$

Characteristic Curves

All test conditions are at 25°C The figures are identical for MKWI40-48S24

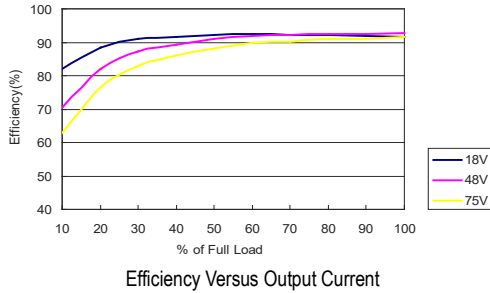

Efficiency Versus Output Current

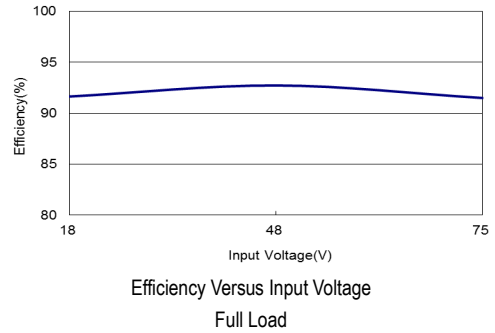

Efficiency Versus Input Voltage Full Load

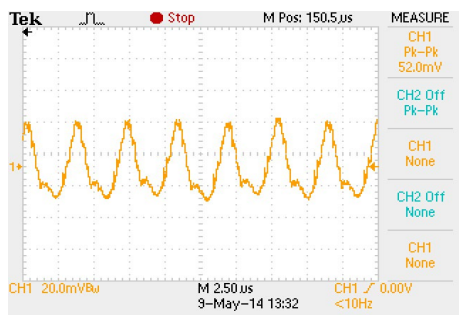

Typical Output Ripple and Noise
 $V_{in}=V_{in\ nom}$; Full Load

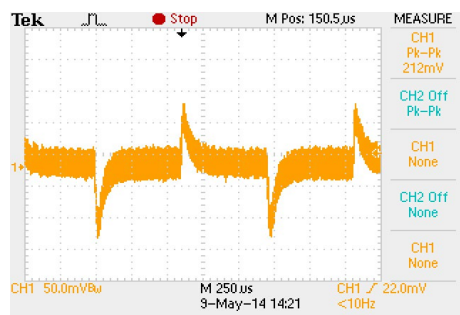

Transient Response to Dynamic Load Change
from 100% to 75% of Full Load ; $V_{in}=V_{in\ nom}$

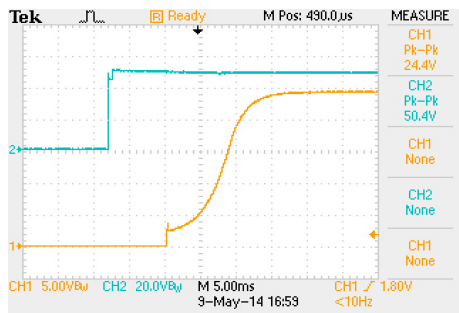

Typical Input Start-Up and Output Rise Characteristic
 $V_{in}=V_{in\ nom}$; Full Load

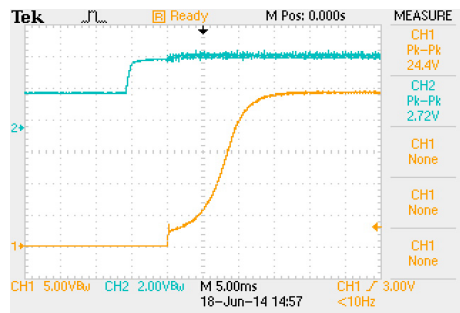

ON/OFF Voltage Start-Up and Output Rise Characteristic
 $V_{in}=V_{in\ nom}$; Full Load

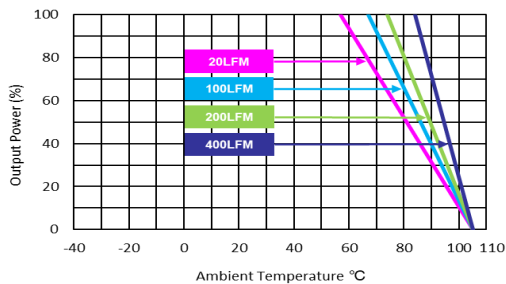

Derating Output Current Versus Ambient Temperature
 $V_{in}=V_{in\ nom}$

Characteristic Curves

All test conditions are at 25°C The figures are identical for MKWI40-48D12

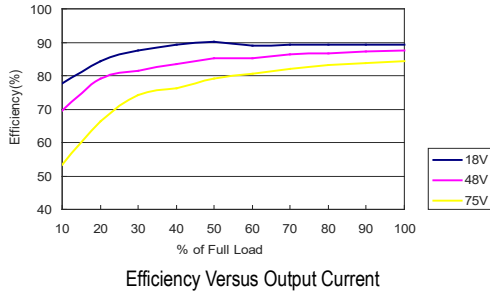

Efficiency Versus Output Current

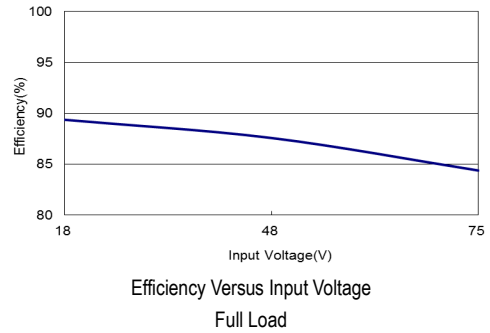

Efficiency Versus Input Voltage Full Load

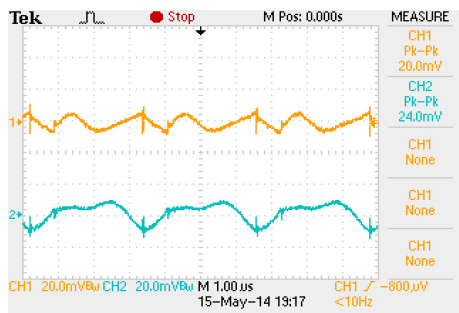

Typical Output Ripple and Noise
 $V_{in}=V_{in,nom}$; Full Load

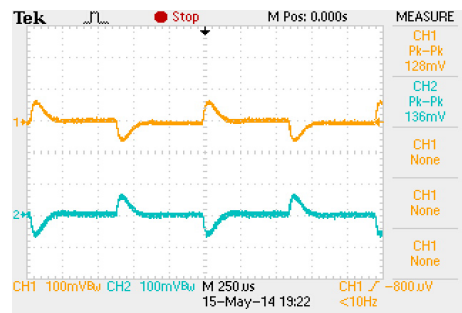

Transient Response to Dynamic Load Change
from 100% to 75% of Full Load ; $V_{in}=V_{in,nom}$

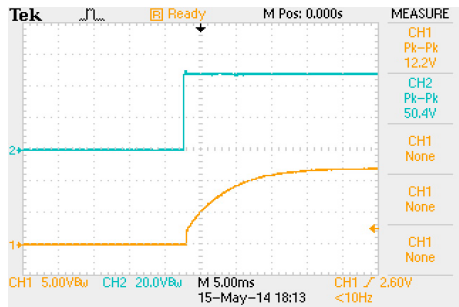

Typical Input Start-up and Output Rise Characteristic
 $V_{in}=V_{in,nom}$; Full Load

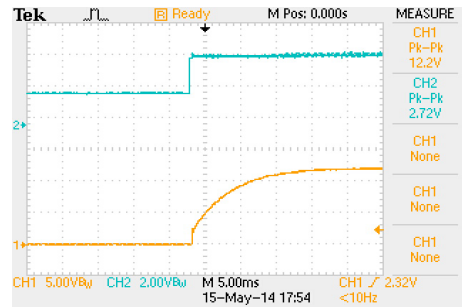

ON/OFF Voltage Start-up and Output Rise Characteristic
 $V_{in}=V_{in,nom}$; Full Load

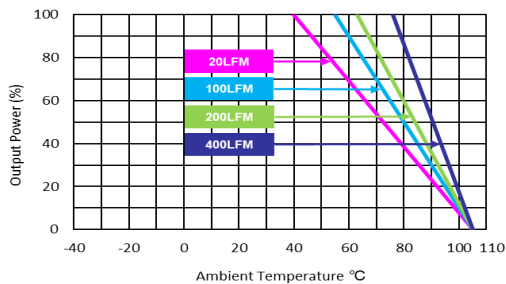

Derating Output Current Versus Ambient Temperature
 $V_{in}=V_{in,nom}$

Characteristic Curves

All test conditions are at 25°C The figures are identical for MKWI40-48D15

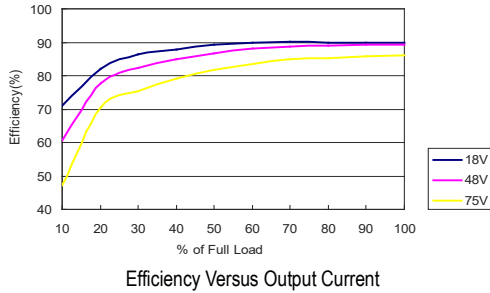

Efficiency Versus Output Current

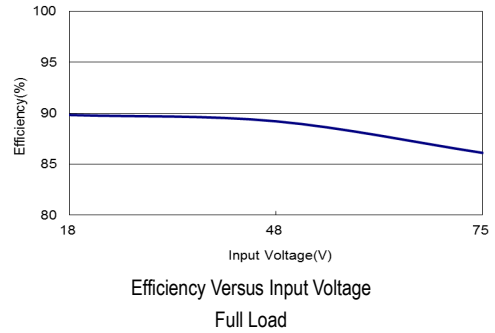

Efficiency Versus Input Voltage Full Load

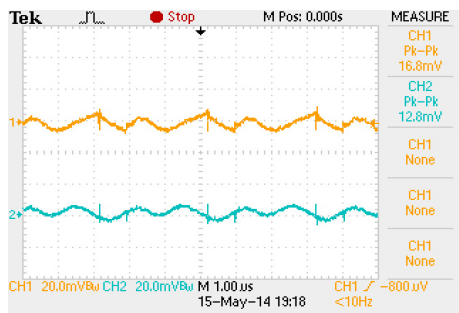

Typical Output Ripple and Noise
 $V_{in}=V_{in nom}$; Full Load

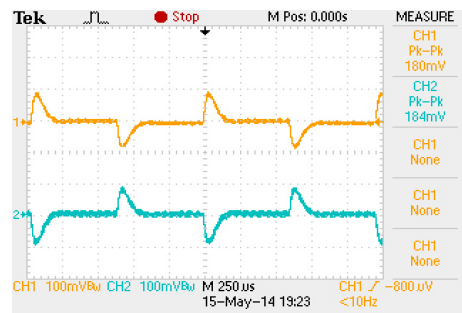

Transient Response to Dynamic Load Change
from 100% to 75% of Full Load ; $V_{in}=V_{in nom}$

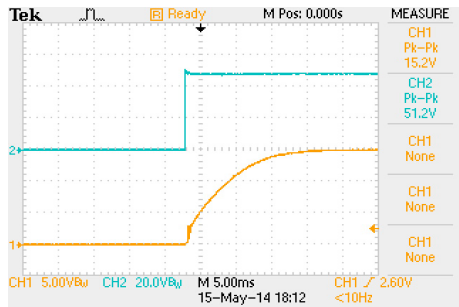

Typical Input Start-up and Output Rise Characteristic
 $V_{in}=V_{in nom}$; Full Load

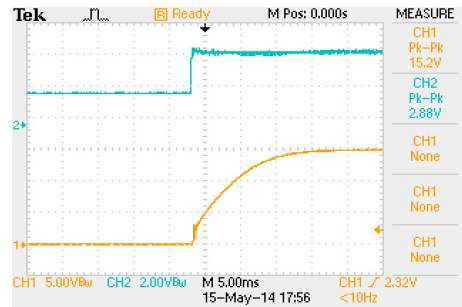

ON/OFF Voltage Start-up and Output Rise Characteristic
 $V_{in}=V_{in nom}$; Full Load

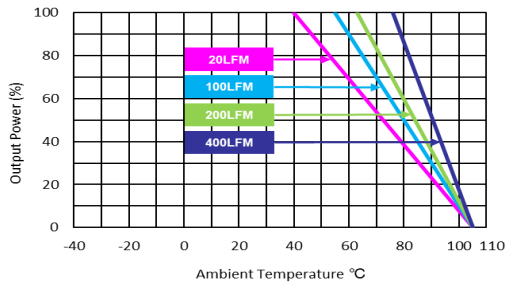

Derating Output Current Versus Ambient Temperature
 $V_{in}=V_{in nom}$

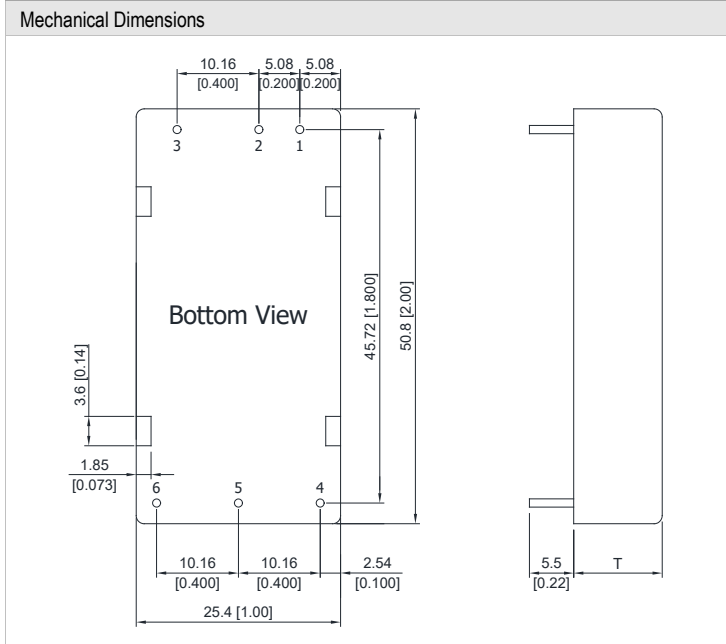
Package Specifications

Pin Connections

Pin	Single Output	Dual Output	Diameter mm (inches)
1	+Vin	+Vin	∅ 1.0 [0.04]
2	-Vin	-Vin	∅ 1.0 [0.04]
3	Remote On/Off	Remote On/Off	∅ 1.0 [0.04]
4	+Vout	+Vout	∅ 1.0 [0.04]
5	-Vout	Common	∅ 1.0 [0.04]
6	Trim	-Vout	∅ 1.0 [0.04]

T: 11.0mm(0.43 inch) for 24V Output Models
 T: 10.2mm(0.40 inch) for Other Output Models

- ▶ All dimensions in mm (inches)
- ▶ Tolerance: X.X±0.25 (X.XX±0.01)
 X.XX±0.13 (X.XXX±0.005)
- ▶ Pin diameter tolerance: X.X±0.05 (X.XX±0.002)

Physical Characteristics

Case Size (24V Output)	: 50.8x25.4x11.0mm (2.0x1.0x0.43 inches)
Case Size (Other Output)	: 50.8x25.4x10.2mm (2.0x1.0x0.40 inches)
Case Material	: Metal With Non-Conductive Baseplate
Base Material	: FR4 PCB (flammability to UL 94V-0 rated)
Pin Material	: Copper Alloy
Weight	: 30g

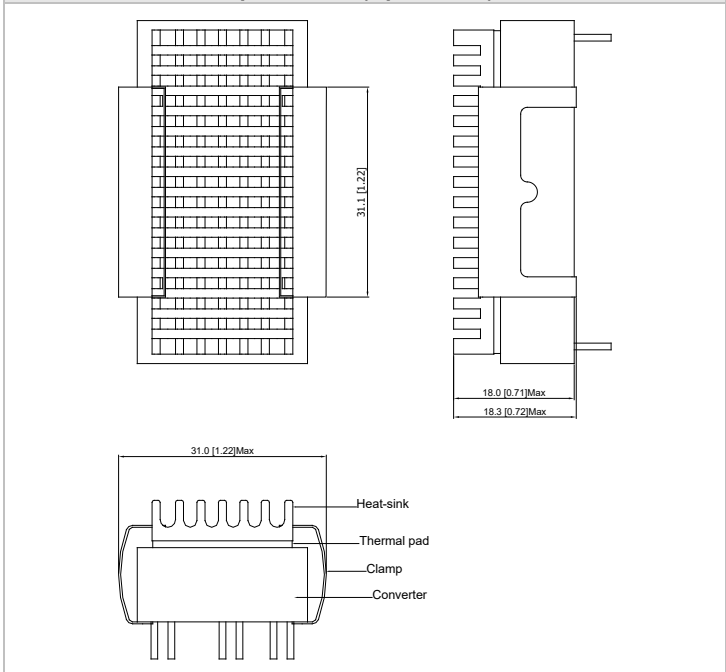
Heatsink For 24V Output Models (Option –HS)

Physical Characteristics

Heatsink Material	: Aluminum
Finish	: Black Anodized Coating
Weight	: 9g

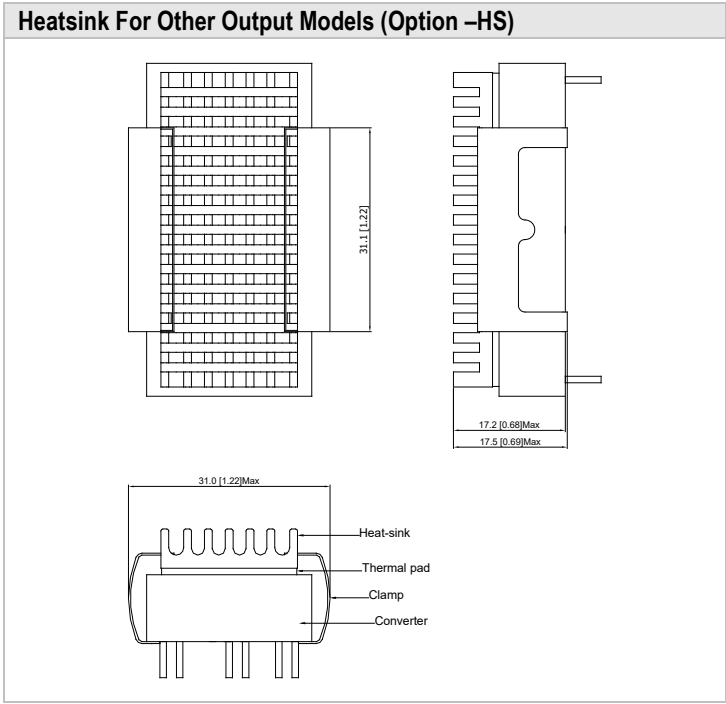
- ▶ The advantages of adding a heatsink are:
1. To improve heat dissipation and increase the stability and reliability of the DC-DC converters at high operating temperatures.
 2. To increase operating temperature of the DC-DC converter, please refer to Derating Curve.



Physical Characteristics	
Heatsink Material	: Aluminum
Finish	: Black Anodized Coating
Weight	: 9g

▶ The advantages of adding a heatsink are:

1. To improve heat dissipation and increase the stability and reliability of the DC-DC converters at high operating temperatures.
2. To increase operating temperature of the DC-DC converter, please refer to Derating Curve.

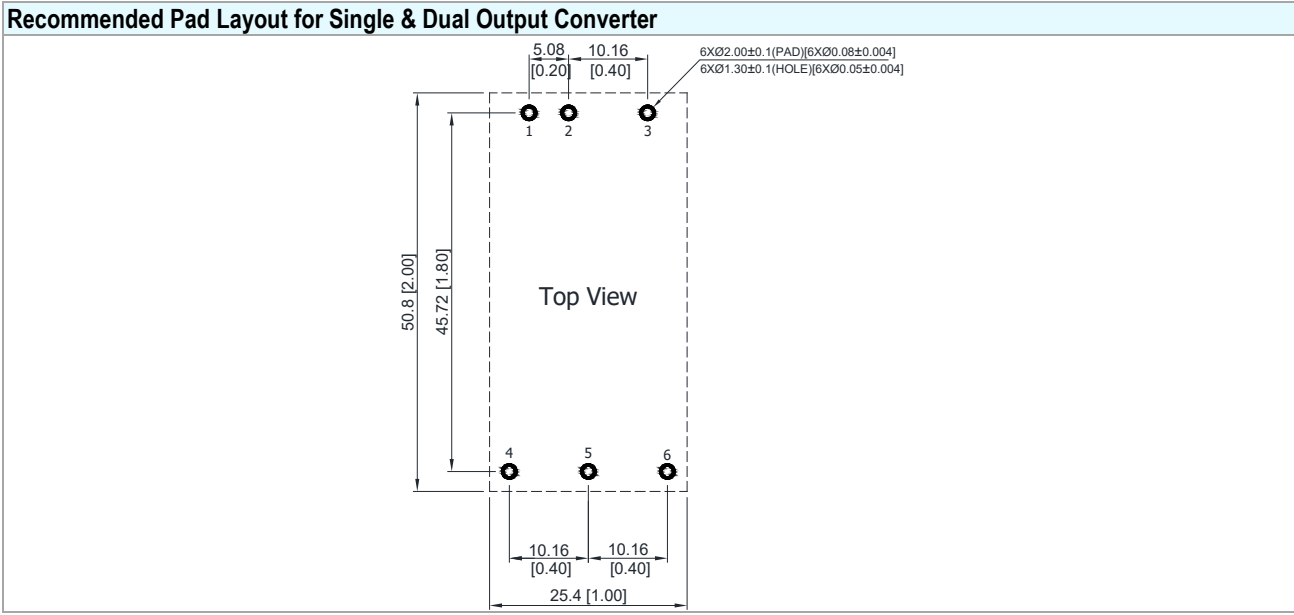

External Output Trimming

Output can be externally trimmed by using the method shown below

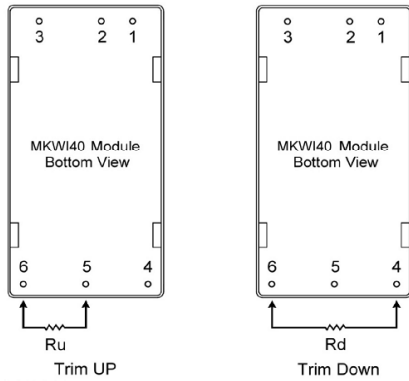

Trim Range (%)	MKWI40-XXS033		MKWI40-XXS05		MKWI40-XXS12		MKWI40-XXS15		MKWI40-XXS24	
	Trim down (kΩ)	Trim up (kΩ)	Trim down (kΩ)	Trim up (kΩ)	Trim down (kΩ)	Trim up (kΩ)	Trim down (kΩ)	Trim up (kΩ)	Trim down (kΩ)	Trim up (kΩ)
1	72.61	60.84	138.88	106.87	413.55	351.00	530.73	422.77	333.39	---
2	32.55	27.40	62.41	47.76	184.55	157.50	238.61	189.89	148.80	243.70
3	19.20	16.25	36.92	28.06	108.22	93.00	141.24	112.26	87.26	---
4	12.52	10.68	24.18	18.21	70.05	60.75	92.56	73.44	56.50	108.50
5	8.51	7.34	16.53	12.30	47.15	41.40	63.35	50.15	38.04	---
6	5.84	5.11	11.44	8.36	31.88	28.50	43.87	34.63	25.73	63.43
7	3.94	3.51	7.79	5.55	20.98	19.29	29.96	23.54	16.94	---
8	2.51	2.32	5.06	3.44	12.80	12.37	19.53	15.22	10.35	40.90
9	1.39	1.39	2.94	1.79	6.44	7.00	11.41	8.75	5.22	---
10	0.50	0.65	1.24	0.48	1.35	2.70	4.92	3.58	1.12	27.38
12	---	---	---	---	---	---	---	---	---	18.37
14	---	---	---	---	---	---	---	---	---	11.93
16	---	---	---	---	---	---	---	---	---	7.10
18	---	---	---	---	---	---	---	---	---	3.34
20	---	---	---	---	---	---	---	---	---	0.34

Test Setup

Input Reflected-Ripple Current Test Setup

Input reflected-ripple current is measured with an inductor L_{in} (4.7 μ H) and C_{in} (220 μ F, ESR < 1.0 Ω at 100 kHz) to simulate source impedance. Capacitor C_{in} , offsets possible battery impedance. Current ripple is measured at the input terminals of the module, measurement bandwidth is 0-500 kHz.

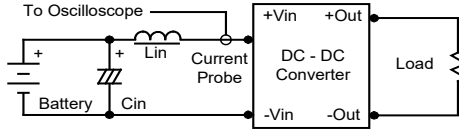

Peak-to-Peak Output Noise Measurement Test

Use a 1 μ F ceramic capacitor and a 10 μ F tantalum capacitor. Scope measurement should be made by using a BNC socket, measurement bandwidth is 0-20 MHz. Position the load between 50 mm and 75 mm from the DC-DC Converter.

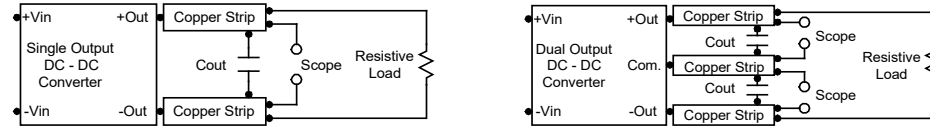

Technical Notes

Remote On/Off

Positive logic remote on/off turns the module on during a logic high voltage on the remote on/off pin, and off during a logic low. To turn the power module on and off, the user must supply a switch to control the voltage between the on/off terminal and the -Vin terminal. The switch can be an open collector or equivalent. A logic low is 0V to 1.2V. A logic high is 4.7V to 12V. The maximum sink current at the on/off terminal (Pin 3) during a logic low is -100 μ A. The maximum allowable leakage current of a switch connected to the on/off terminal (Pin 3) at logic high (2.5V to 100V) is 5 μ A.

Overcurrent Protection

To provide hiccup mode protection in a fault (output overload) condition, the unit is equipped with internal current limiting circuitry and can endure overload for an unlimited duration.

Overvoltage Protection

The output overvoltage clamp consists of control circuitry, which is independent of the primary regulation loop, that monitors the voltage on the output terminals. The control loop of the clamp has a higher voltage set point than the primary loop. This provides a redundant voltage control that reduces the risk of output overvoltage. The OVP level can be found in the output data.

Input Source Impedance

The power module should be connected to a low ac-impedance input source. Highly inductive source impedances can affect the stability of the power module. In applications where power is supplied over long lines and output loading is high, it may be necessary to use a capacitor at the input to ensure startup. Capacitor mounted close to the power module helps ensure stability of the unit, it is recommended to use a good quality low Equivalent Series Resistance (ESR < 1.0 Ω at 100 kHz) capacitor of a 10 μ F for the 24V and 48V devices.

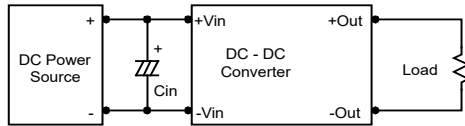

Output Ripple Reduction

A good quality low ESR capacitor placed as close as practicable across the load will give the best ripple and noise performance. To reduce output ripple, it is recommended to use 4.7 μ F capacitors at the output.



Maximum Capacitive Load

The MKWI40 series has limitation of maximum connected capacitance at the output. The power module may be operated in current limiting mode during start-up, affecting the ramp-up and the startup time. The maximum capacitance can be found in the data sheet.

Thermal Considerations

Many conditions affect the thermal performance of the power module, such as orientation, airflow over the module and board spacing. To avoid exceeding the maximum temperature rating of the components inside the power module, the case temperature must be kept below 105 $^{\circ}$ C. The derating curves are determined from measurements obtained in a test setup.

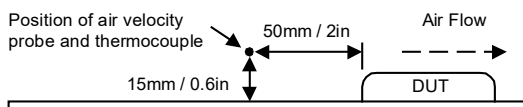

Remote ON/OFF Implementation

With suffix-RC, the positive logic remote ON/OFF control circuit is included. Turns the module ON during logic High on the ON/Off pin and turns OFF during logic Low. The ON/OFF input signal (Von/off) that referenced to GND. If not using the remote on/off feature, please open circuit between on/off pin and -Vin pin to turn the module on.

Remote ON/OFF implementation

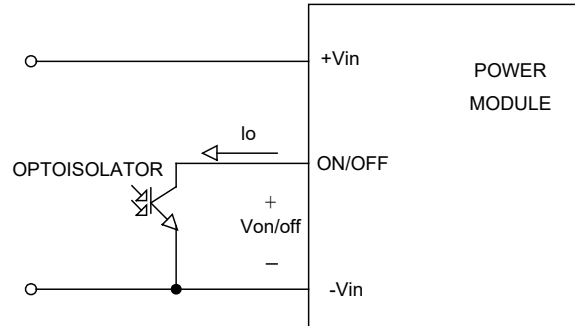

Isolated-Closure Remote ON/OFF

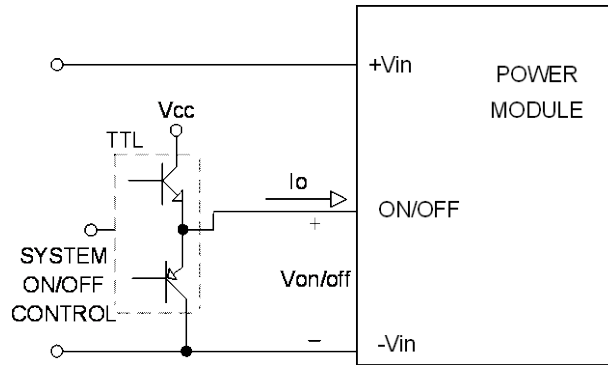

Level Control Using TTL Output

Packaging Information for Tube

Tube

Nail

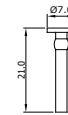
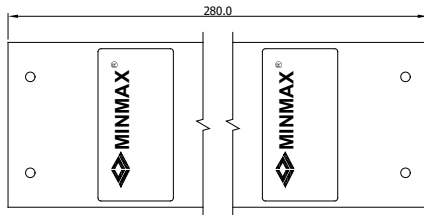
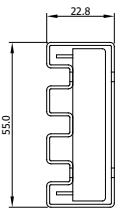

Unit: mm

10 PCS per TUBE (without Heatsink)

Tube

Nail

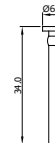
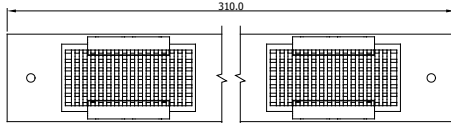
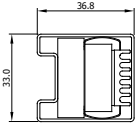

Unit: mm

5 PCS per TUBE (with Heatsink)

Wave Soldering Considerations

Lead free wave solder profile

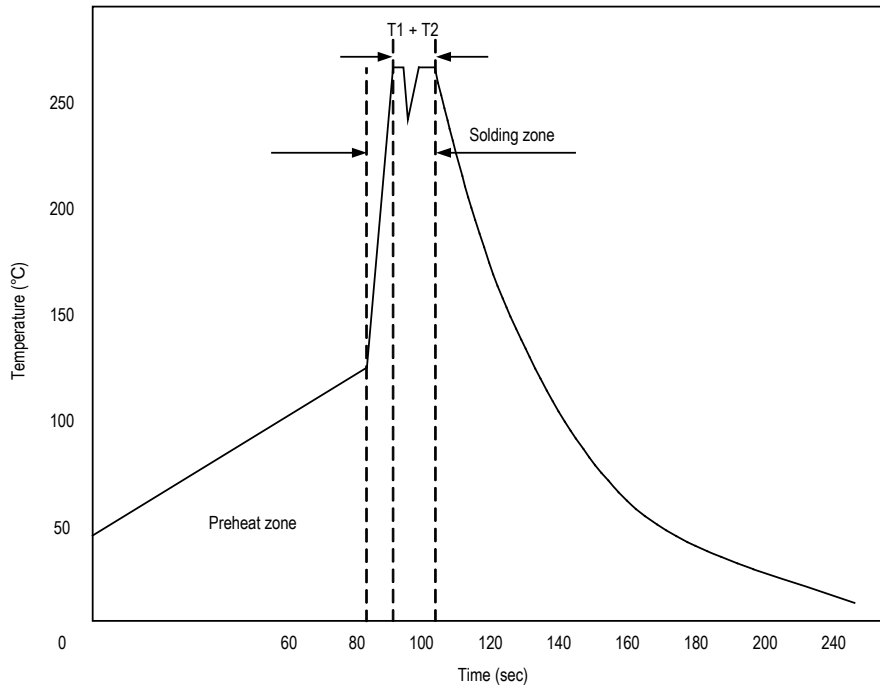

Zone	Reference Parameter
Preheat	Rise temp. speed : 3°C/sec max.
zone	Preheat temp. : 100~130°C
Actual	Peak temp. : 250~260°C
heating	Peak time(T1+T2) : 4~6 sec

Hand Welding Parameter

Reference Solder: Sn-Ag-Cu : Sn-Cu : Sn-Ag

Hand Welding: Soldering iron : Power 60W

Welding Time: 2~4 sec

Temp.: 380~400°C

Part Number Structure							
M	K	WI	40	-	24	S	033
Package Type 2" X 1"		Ultra-wide 4:1 Input Voltage Range	Output Power 40 Watt		Input Voltage Range 24: 9 ~ 36 VDC 48: 18 ~ 75 VDC	Output Quantity S: Single D: Dual	Output Voltage 033: 3.3 VDC 05: 5 VDC 12: 12 VDC 15: 15 VDC 24: 24 VDC

MTBF and Reliability		
The MTBF of MKWI40 series of DC-DC converters has been calculated using MIL-HDBK 217F NOTICE2, Operating Temperature 25°C, Ground Benign.		
Model	MTBF	Unit
MKWI40-24S033	720,784	Hours
MKWI40-24S05	401,292	
MKWI40-24S12	343,923	
MKWI40-24S15	348,480	
MKWI40-24S24	541,511	
MKWI40-24D12	328,170	
MKWI40-24D15	339,416	
MKWI40-48S033	603,205	
MKWI40-48S05	346,962	
MKWI40-48S12	408,443	
MKWI40-48S15	396,294	
MKWI40-48S24	551,073	
MKWI40-48D12	330,268	
MKWI40-48D15	330,511	