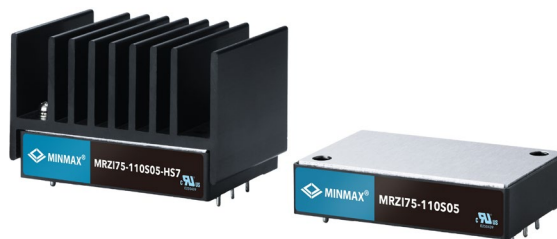

FEATURES

- ▶ Industrial Standard Quarter Brick Package
- ▶ Ultra-wide Input Range 36-160VDC
- ▶ Excellent Efficiency up to 91%
- ▶ I/O Isolation 2000VAC with Reinforced Insulation
- ▶ Operating Baseplate Temp. Range -40°C to +105°C
- ▶ Passed Temperature Cycle Test (TCT) more than 500 Cycles
- ▶ No Min. Load Requirement
- ▶ Under-voltage, Overload/Voltage/Temp. and Short Circuit Protection
- ▶ Remote On/Off Control, Output Voltage Trim, Output Sense
- ▶ Vibration and Shock/Bump Test EN 61373 Approved
- ▶ Cooling, Dry & Damp Heat Test IEC/EN 60068-2-1, 2, 30 Approved
- ▶ Railway EMC Standard EN 50121-3-2 Approved
- ▶ Railway Certified EN 50155 (IEC60571) Approved
- ▶ Fire Protection Test EN 45545-2 Approved
- ▶ UL/cUL/IEC/EN 62368-1 Safety Approval & CE Marking (Pending)

NEW

PRODUCT OVERVIEW

The MINMAX MRZI75 series is a new generation of high-performance 75W isolated DC-DC converters in a quarter-brick package, specifically designed for railway applications. It features a wide input range of 36-160 VDC and offers stable output voltage options of 5, 12, 15, 24, and 54 VDC (suitable for PoE applications), providing a range of choices for various railway needs.

With its advanced circuit topology, the MRZI75 series delivers an impressive efficiency of up to 91%, enabling baseplate temperatures to reach up to 105°C. The series also provides high I/O isolation of up to 2000VAC with reinforced insulation, designed to endure harsh environmental conditions.

Key features include protection against under-voltage, overload, over-voltage, over-temperature, and short circuits. It also supports remote On/Off control (with both positive and negative logic), output voltage trimming, and output sensing for precise power regulation. Notably, the MRZI75 series has passed the Temperature Cycle Test (TCT) with over 500 cycles, ensuring enhanced reliability in extreme operating conditions.

The MRZI75 series is certified to the railway standard EN 50155 and the EMC standard EN 50121-3-2, meeting stringent safety and environmental requirements for railway use. Additionally, it complies with the EN 45545-2 fire protection standard, ensuring safety during railway and railroad vehicle operations.

This series is ideal for a variety of railway applications, such as traction control systems, onboard lighting, communication systems, surveillance equipment, and HVAC systems, providing reliable power conversion in demanding environments.

Model Selection Guide

Model Number	Input Voltage (Range) VDC	Output Voltage VDC	Output Current Max. A	Input Current		Over Voltage Protection VDC	Max. capacitive Load μF	Efficiency (typ.) @Max. Load %
				@Max. Load mA(typ.)	@No Load mA(typ.)			
MRZI75-110S05	110 (36 ~ 160)	5	15	766	43	6.2	30000	89
MRZI75-110S12		12	6.25	749	43	15	5200	91
MRZI75-110S15		15	5	749	43	18	3300	91
MRZI75-110S24		24	3.125	758	43	30	1200	90
MRZI75-110S54		54	1.39	767	43	66	330	89

Input Specifications

Parameter	Min.	Typ.	Max.	Unit
Input Surge Voltage (1000ms. max)	-0.7	---	200	VDC
Start-up Threshold Voltage	---	---	36	
Under Voltage Shutdown	---	32	---	
Input Filter	Internal Capacitor			

Output Specifications							
Parameter		Conditions		Min.	Typ.	Max.	Unit
Output Voltage Setting Accuracy				---	---	±1.0	%
Line Regulation		Vin=Min. to Max. @ Full Load		---	---	±0.2	%
Load Regulation		Min. Load to Full Load		---	---	±0.3	%
Min.Load		No minimum Load Requirement					
Ripple & Noise	0-20 MHz Bandwidth	5V, 12V, 15V Output	Measured with a 22uF/25V POS-CAP	---	---	100	mV _{P-P}
		24V Output	Measured with a 33uF/35V POLYMER	---	---	150	mV _{P-P}
		54V Output	Measured with a 1uF/100V MLCC	---	---	300	mV _{P-P}
Start Up Time (Power On)				---	---	70	ms
Transient Recovery Time		25% Load Step Change (2)		---	250	---	μs
Transient Response Deviation				---	±3	±5	%
Temperature Coefficient				---	---	±0.02	%/°C
Trim Up / Down Range (8)	% of Nominal Output Voltage	Other Models		---	---	±10	%
		54V Output		---	---	+5 / -15	%
Over Load Protection		Current Limitation at 150% typ. of Iout max., Hiccup					
Short Circuit Protection		Continuous, Automatic Recovery (Hiccup Mode 0.3Hz typ.)					

General Specifications							
Parameter		Conditions		Min.	Typ.	Max.	Unit
I/O Isolation Voltage		Reinforced Insulation, Rated For 60 Seconds		2000	---	---	VAC
Isolation Voltage	Input to case	Rated For 60 Seconds		1680	---	---	VAC
	Output to case			500	---	---	VAC
I/O Isolation Resistance		500 VDC		1000	---	---	MΩ
I/O Isolation Capacitance		100kHz, 1V		---	---	2200	pF
Switching Frequency		5V Output		---	185	---	kHz
		Other Models		---	214	---	kHz
MTBF(calculated)		MIL-HDBK-217F@25°C Full Load, Ground Benign		642,314	---	---	Hours
Safety Standards		EN 50155, IEC 60571					
		UL/cUL 62368-1 recognition(UL certificate), IEC/EN 62368-1					

Remote On/Off Control							
Parameter		Conditions		Min.	Typ.	Max.	Unit
Positive logic (Standard)	Converter On	3.5V ~ 12V or Open Circuit					
	Converter Off	0V ~ 1.2V or Short Circuit					
Negative logic (Option)	Converter On	0V ~ 1.2V or Short Circuit					
	Converter Off	3.5V ~ 12V or Open Circuit					
Positive logic	Control Input Current	Converter On	Vctrl = 5.0V	---	0.5	---	mA
		Converter Off	Vctrl = 0V	---	-0.5	---	mA
Negative logic	Control Input Current	Converter On	Vctrl = 0V	---	-0.5	---	mA
		Converter Off	Vctrl = 5.0V	---	0.5	---	mA
Control Common		Referenced to Negative Input					
Standby Input Current		Nominal Vin		---	3	---	mA

EMC Specifications			
Parameter	Standards & Level		Performance
General	Compliance with EN 50121-3-2 Railway Applications		
EMI ₍₅₎	Conduction	EN 55032/11	With external components
	Radiation		
EMS ₍₅₎	EN 55024, EN 55035		
	ESD	Direct discharge	Indirect discharge HCP & VCP Contact ± 6kV
		EN 61000-4-2 air ± 8kV, Contact ± 6kV	
	Radiated immunity	EN 61000-4-3 10V/m	
	Fast transient	EN 61000-4-4 ±2kV	
	Surge	EN 61000-4-5 ±2kV	
	Conducted immunity	EN 61000-4-6 10Vrms	
PFMF	EN 61000-4-8 30A/m for Continuous		

Environmental Specifications						
Parameter	Model	Min.	Typ.	Max.	Unit	
Baseplate Temperature Range		-40	---	+105	°C	
Over Temperature Protection (Baseplate)		---	+110	---	°C	
Storage Temperature Range		-50	---	+125	°C	
Cooling Test	Compliance to IEC/EN60068-2-1					
Dry Heat	Compliance to IEC/EN60068-2-2					
Damp Heat	Compliance to IEC/EN60068-2-30					
Vibration and Shock/Bump	Compliance to IEC/EN 61373					
Operating Humidity (non condensing)			5	95	% rel. H	
Lead Temperature (1.5mm from case for 10Sec.)			---	260	°C	

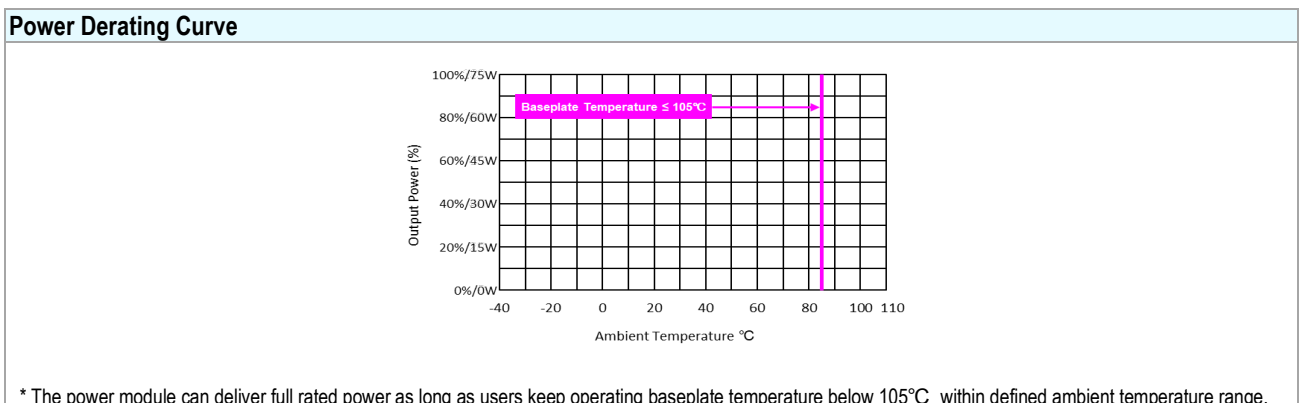

Notes	
1	Specifications typical at Ta=+25°C, resistive load, nominal input voltage and rated output current unless otherwise noted.
2	Transient recovery time is measured to within 1% error band for a step change in output load of 75% to 100%.
3	Other input and output voltage may be available, please contact MINMAX.
4	It is necessary to parallel a capacitor across the input pins under normal operation. Minimum Capacitance: 150µF/ 250V KXJ.
5	The external components might be required to meet EMI/EMS standard for some of test items. Please contact MINMAX for the solution in detail.
6	The hot-swap operation is extremely prohibited.
7	Over Current Protection (OCP) is built in and works over 130% of the rated current or higher. However, use in an over current situation over 4 seconds must be avoided whenever possible.
8	Do not exceed maximum power specification when adjusting output voltage. Please see the External Output Trimming table at page 7.
9	Specifications are subject to change without notice.
10	The repeated high voltage isolation testing of the converter can degrade isolation capability, to a lesser or greater degree depending on materials, construction, environment and reflow solder process. Any material is susceptible to eventual chemical degradation when subject to very high applied voltages thus implying that the number of tests should be strictly limited. We therefore strongly advise against repeated high voltage isolation testing, but if it is absolutely required, that the voltage be reduced by 20% from specified test voltage. Furthermore, the high voltage isolation capability after reflow solder process should be evaluated as it is applied on system.

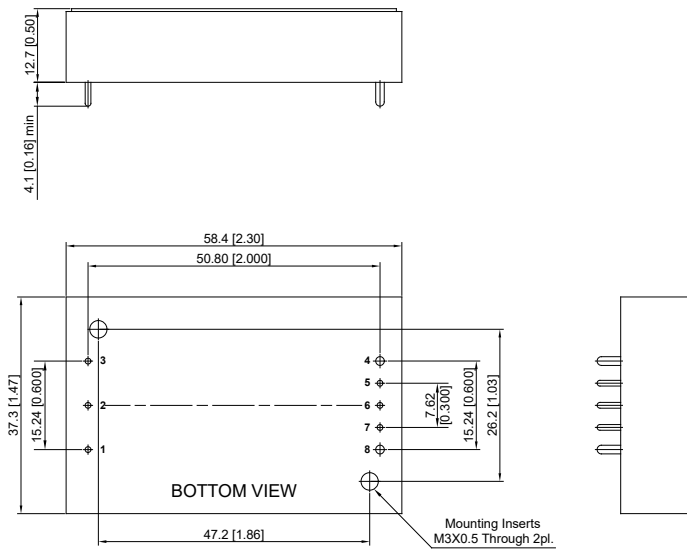
Package Specifications
Mechanical Dimensions

Pin Connections

Pin	Function	Diameter mm (inches)
1	+Vin	∅ 1.0 [0.04]
2	Remote On/Off	∅ 1.0 [0.04]
3	-Vin	∅ 1.0 [0.04]
4	-Vout	∅ 1.5 [0.06]
5	* -Sense	∅ 1.0 [0.04]
6	Trim	∅ 1.0 [0.04]
7	* +Sense	∅ 1.0 [0.04]
8	+Vout	∅ 1.5 [0.06]

* If remote sense not used the +sense should be connected to +output and -sense should be connected to -output
 Maximum output deviation is 10% inclusive of trim

- ▶ All dimensions in mm (inches)
- ▶ Tolerance: X.X±0.5 (X.XX±0.02)
X.XX±0.25 (X.XXX±0.01)
- ▶ Pin diameter tolerance: X.X±0.05 (X.XX±0.002)

Physical Characteristics

Case Size	: 58.4x37.3x12.7 mm (2.30x1.47x0.50 inches)
Case Material	: Plastic resin (flammability to UL 94V-0 rated)
Top Side Base Material	: Aluminum Plate
Pin Material	: Copper
Potting Material	: Silicone (UL94-V0)
Weight	: 70g

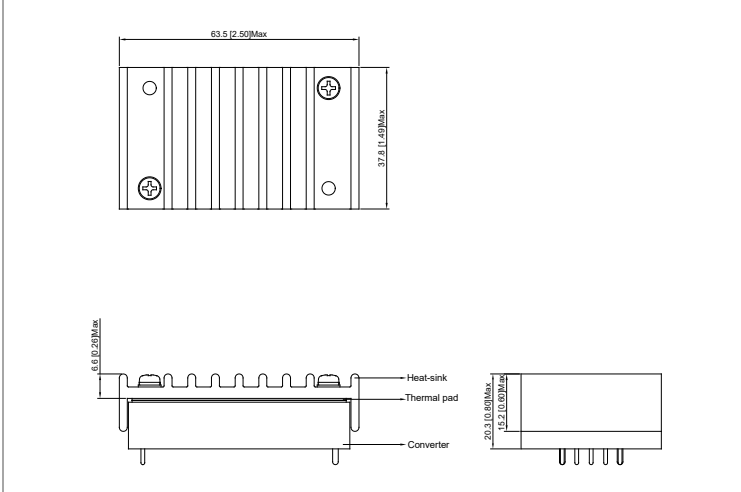
Heatsink (Option –HS5)

Physical Characteristics

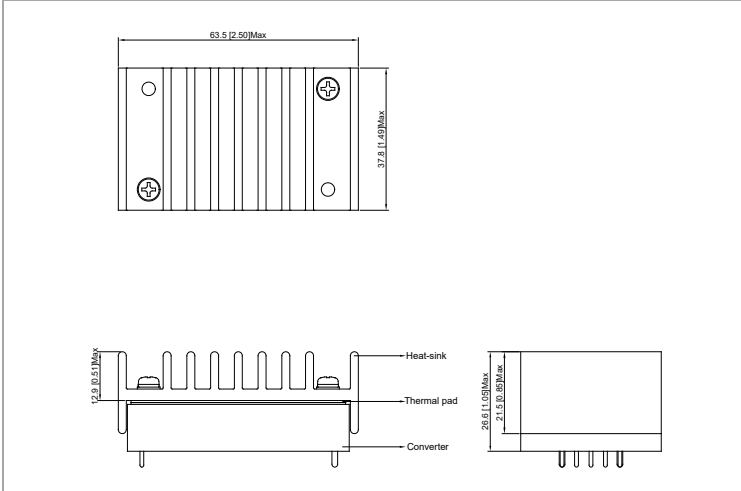
Heatsink Material	:	Aluminum
Finish	:	Black Anodized Coating
Weight	:	27g

Heatsink (Option –HS6)

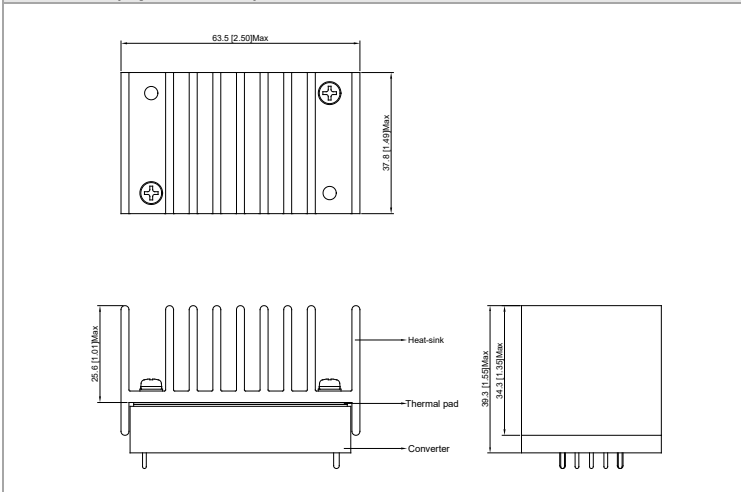
Physical Characteristics

Heatsink Material	:	Aluminum
Finish	:	Black Anodized Coating
Weight	:	38g

Heatsink (Option –HS7)

Physical Characteristics

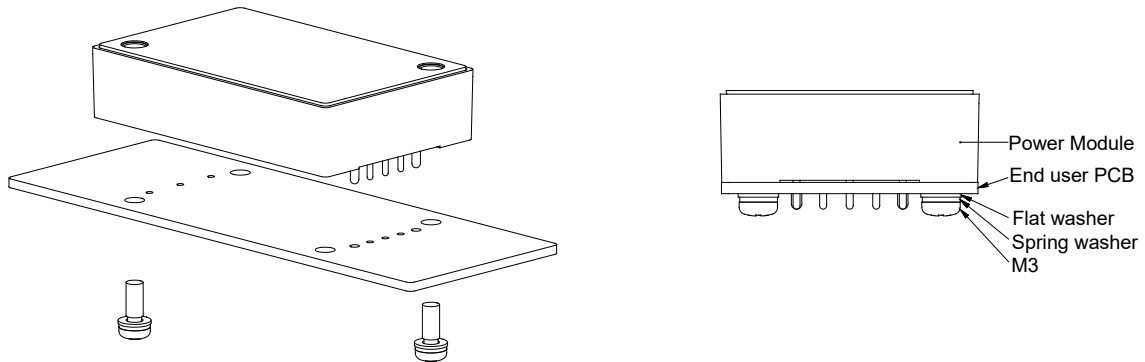
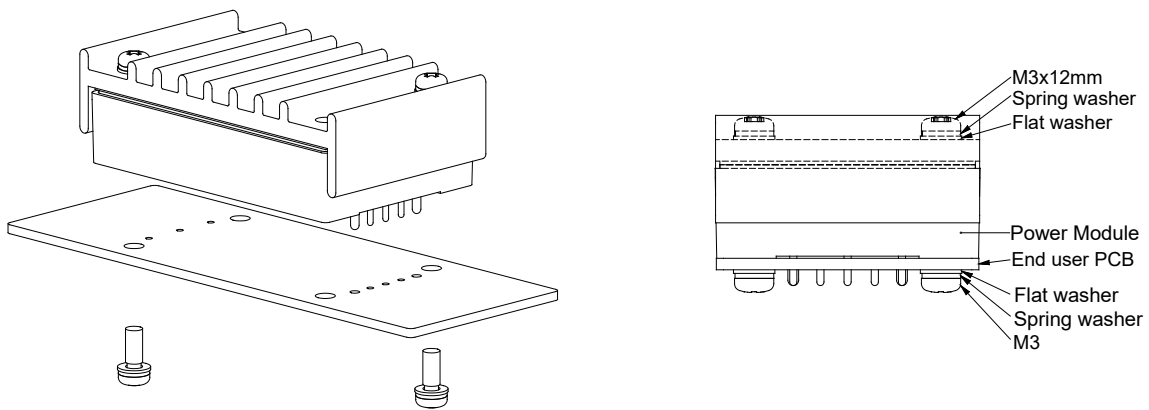
Heatsink Material	:	Aluminum
Finish	:	Black Anodized Coating
Weight	:	63g

*For more power derating information, please refer to E.C Note.

PCB Installation of End Users
Standard Kit

Heatsink Kit

1. Please evaluate mechanical stress (vibration, shock, bump) during field applications.
2. It has to equip with installation kit if excess the guaranteed specifications, please contact MINMAX for detail information.
3. Applied torque per screw 5 kgf.cm min.

External Output Trimming

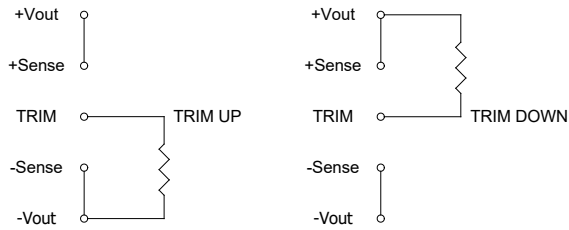
Output can be externally trimmed by using the method shown below



	MRZI75-110S05		MRZI75-110S12		MRZI75-110S15		MRZI75-110S24		MRZI75-110S54	
Trim Range (%)	Trim down (kΩ)	Trim up (kΩ)	Trim down (kΩ)	Trim up (kΩ)	Trim down (kΩ)	Trim up (kΩ)	Trim down (kΩ)	Trim up (kΩ)	Trim down (kΩ)	Trim up (kΩ)
1	138.88	106.87	413.55	351.00	530.73	422.77	599.27	486.53	1,882.57	560.73
2	62.41	47.76	184.55	157.50	238.61	189.89	268.09	217.71	877.94	230.36
3	36.92	28.06	108.22	93.00	141.24	112.26	157.69	218.11	543.06	120.24
4	24.18	18.21	70.05	60.75	92.56	73.44	102.49	83.31	375.62	65.18
5	16.53	12.30	47.15	41.40	63.35	50.15	69.37	56.43	275.15	32.15
6	11.44	8.36	31.88	28.50	43.87	34.63	47.3	38.5	208.18	---
7	7.79	5.55	20.98	19.29	29.96	23.54	31.52	25.7	160.34	---
8	5.06	3.44	12.80	12.37	19.53	15.22	19.7	16.1	124.46	---
9	2.94	1.79	6.44	7.00	11.41	8.75	10.5	8.64	96.55	---
10	1.24	0.48	1.35	2.70	4.92	3.58	3.14	2.66	74.23	---
11	---	---	---	---	---	---	---	---	55.96	---
12	---	---	---	---	---	---	---	---	40.74	---
13	---	---	---	---	---	---	---	---	27.86	---
14	---	---	---	---	---	---	---	---	16.82	---
15	---	---	---	---	---	---	---	---	7.25	---

Order Code Table For Converter and Converter With Heatsink

Standard (Positive logic)	With heatsink (Positive logic)		
	MRZI75 + HS-QB005	MRZI75 + HS-QB006	MRZI75 + HS-QB007
MRZI75-110S05	MRZI75-110S05-HS5	MRZI75-110S05-HS6	MRZI75-110S05-HS7
MRZI75-110S12	MRZI75-110S12-HS5	MRZI75-110S12-HS6	MRZI75-110S12-HS7
MRZI75-110S15	MRZI75-110S15-HS5	MRZI75-110S15-HS6	MRZI75-110S15-HS7
MRZI75-110S24	MRZI75-110S24-HS5	MRZI75-110S24-HS6	MRZI75-110S24-HS7
MRZI75-110S54	MRZI75-110S54-HS5	MRZI75-110S54-HS6	MRZI75-110S54-HS7
Negative logic	With heatsink (Negative logic)		
	MRZI75 + HS-QB005	MRZI75 + HS-QB006	MRZI75 + HS-QB007
MRZI75-110S05N	MRZI75-110S05N-HS5	MRZI75-110S05N-HS6	MRZI75-110S05N-HS7
MRZI75-110S12N	MRZI75-110S12N-HS5	MRZI75-110S12N-HS6	MRZI75-110S12N-HS7
MRZI75-110S15N	MRZI75-110S15N-HS5	MRZI75-110S15N-HS6	MRZI75-110S15N-HS7
MRZI75-110S24N	MRZI75-110S24N-HS5	MRZI75-110S24N-HS6	MRZI75-110S24N-HS7
MRZI75-110S54N	MRZI75-110S54N-HS5	MRZI75-110S54N-HS6	MRZI75-110S54N-HS7

Order Code Table For Heatsink kit (including: Heatsink x1, Screw (M3/14mm) x 2, Thermal Pad x1)

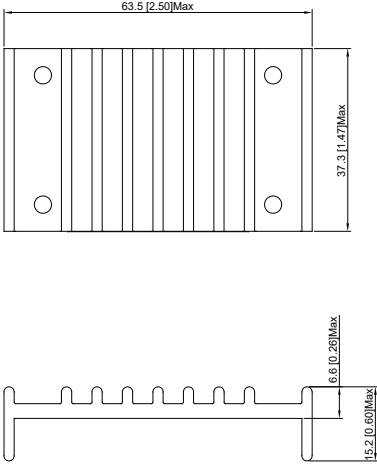
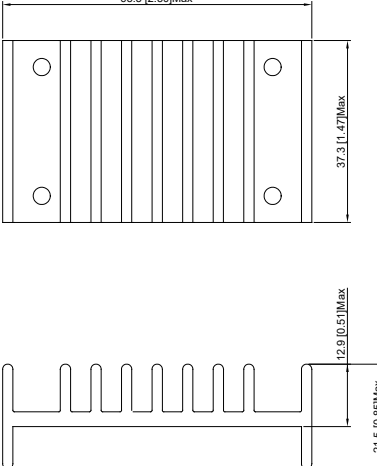
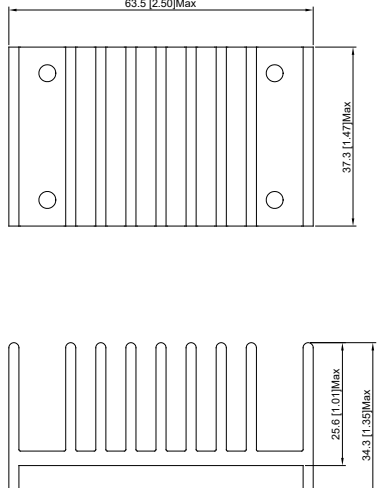
HS-QB005	HS-QB006	HS-QB007
		

Test Setup

Peak-to-Peak Output Noise Measurement Test

Use a 22 μ F polymer capacitor for 5V, 12V, 15V output models and a 33 μ F polymer capacitor for 24V output model and a 1 μ F ceramic capacitor for 54V output model. Scope measurement should be made by using a BNC socket, measurement bandwidth is 0-20 MHz. Position the load between 50 mm and 75 mm from the DC-DC Converter.

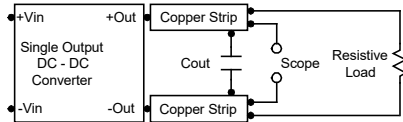

Technical Notes

Remote On/Off

Positive logic remote on/off turns the module on during a logic high voltage on the remote on/off pin, and off during a logic low. To turn the power module on and off, the user must supply a switch to control the voltage between the on/off terminal and the -Vin terminal. The switch can be an open collector or equivalent. A logic low is 0V to 1.2V. A logic high is 3.5V to 12V. The maximum sink current at the on/off terminal (Pin 2) during a logic low is -500 μ A.

Negative logic remote on/off turns the module on during a logic low voltage on the remote on/off pin, and off during a logic high. To turn the power module on and off, the user must supply a switch to control the voltage between the on/off terminal and the -Vin terminal. The switch can be an open collector or equivalent. A logic low is 0V to 1.2V. A logic high is 3.5V to 12V. The maximum source current at the on/off terminal (Pin 2) during a logic high is 500 μ A.

Overload Protection

To provide hiccup mode protection in a fault (output overload) condition, the unit is equipped with internal current limiting circuitry and can endure overload for an unlimited duration.

Oversvoltage Protection

The output oversvoltage clamp consists of control circuitry, which is independent of the primary regulation loop, that monitors the voltage on the output terminals. The control loop of the clamp has a higher voltage set point than the primary loop. This provides a redundant voltage control that reduces the risk of output oversvoltage. The OVP level can be found in the output data.

Output Ripple Reduction

A good quality low ESR capacitor placed as close as practicable across the load will give the best ripple and noise performance. To reduce output ripple, it is recommended to use 4.7 μ F capacitors at the output.

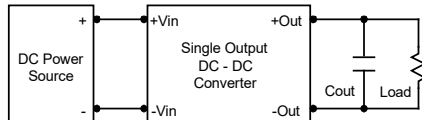

Maximum Capacitive Load

The MRZI75 series has limitation of maximum connected capacitance at the output. The power module may be operated in current limiting mode during start-up, affecting the ramp-up and the startup time. The maximum capacitance can be found in the data sheet.

Thermal Considerations

Many conditions affect the thermal performance of the power module, such as orientation, airflow over the module and board spacing. To avoid exceeding the maximum temperature rating of the components inside the power module, the baseplate temperature must be kept below 105°C. The derating curves are determined from measurements obtained in a test setup.

